

# Service Manual

Notebook Computer

**CF-Y5**

**TOUGHBOOK**

This is the Service Manual for  
the following areas.  
M ...for U.S.A. and Canada

Model No. CF-Y5LWVYZ 1 2

1: Operation System

B: Microsoft® Windows® XP Professional

2: Area

M: Refer to above area table

**⚠ WARNING**

This service information is designed for experienced repair technicians only and is not designed for use by the general public. It does not contain warnings or cautions to advise non-technical individuals of potential dangers in attempting to service a product. Products powered by electricity should be serviced or repaired only by experienced professional technicians. Any attempt to service or repair the product or products dealt with in this service information by anyone else could result in serious injury or death.

**Panasonic®**

© 2006 Matsushita Electric Industrial Co., Ltd. All rights reserved.  
Unauthorized copying and distribution is a violation of law.

# WARNING

For U.K.

## **This apparatus must be earthed for your safety.**

To ensure safe operation the three-pin plug must be inserted only into a standard three-pin power point which is effectively earthed through the normal household wiring.

Extension cords used with the equipment must be three-core and be correctly wired to provide connection to earth. Wrongly wired extension cords are a major cause of fatalities.

The fact that the equipment operates satisfactorily does not imply that the power point is earthed and that the installation is completely safe.

For your safety, if you have any doubt about the effective earthing of the power point, consult a qualified electrician.

## **FOR YOUR SAFETY PLEASE READ THE FOLLOWING TEXT CAREFULLY**

This appliance is supplied with a moulded three pin mains plug for your safety and convenience.

A 3 amp fuse is fitted in this plug.

Should the fuse need to be replaced please ensure that the replacement fuse has a rating of 3 amps and that it is approved by ASTA or BSI to BS 1362.

Check for the ASTA mark  or the BSI mark  on the body of the fuse.

If the plug contains a removable fuse cover you must ensure that it is refitted when the fuse is replaced.

If you lose the fuse cover the plug must not be used until a replacement cover is obtained.

A replacement fuse cover can be purchased from your local Panasonic Dealer.

**IF THE FITTED MOULDED PLUG IS UNSUITABLE FOR THE SOCKET OUTLET IN YOUR HOME THEN THE FUSE SHOULD BE REMOVED AND THE PLUG CUT OFF AND DISPOSED OF SAFELY.**

**THERE IS A DANGER OF SEVERE ELECTRICAL SHOCK IF THE CUT OFF PLUG IS INSERTED INTO ANY 13 AMP SOCKET.**

If a new plug is to be fitted please observe the wiring code as shown below.

If in any doubt please consult a qualified electrician.

**Warning: THIS APPLIANCE MUST BE EARTHED.**

### **Important**

The wires in this mains lead are coloured in accordance with the following code:

Green-and-yellow:	Earth
Blue:	Neutral
Brown:	Live

As the colours of the wires in the mains lead of this apparatus may not correspond with the coloured markings identifying the terminals in your plug, proceed as follows:

The wire which is coloured GREEN-and-YELLOW must be connected to the terminal in the plug which is marked by the letter E or by the safety earth symbol  coloured GREEN or GREEN-and-YELLOW.

The wire which is coloured Blue must be connected to the terminal which is marked with the letter N or coloured BLACK.

The wire which is coloured Brown must be connected to the terminal which is marked with the letter L or coloured RED.

The mains plug on this equipment must be used to disconnect the mains power.

Please ensure that a socket outlet is available near the equipment and shall be easily accessible.

## **How to replace the fuse**

Open the fuse compartment with a screwdriver and replace the fuse.

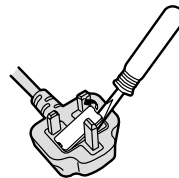

### **Warnings**

- This equipment is not designed for connection to an IT power system.  
(An IT system is a system having no direct connections between live parts and Earth; the exposed-conductive parts of the electrical installation are earthed.  
An IT system is not permitted where the computer is directly connected to public supply systems in the U.K.)
- Disconnect the mains plug from the supply socket when the computer is not in use.

This equipment is produced to BS800/1983.

# LASER SAFETY INFORMATION

For U.S.A.

Class 1 LASER-Product

This product is certified to comply with DHHS Rules 21 CFR Subchapter J.

This product complies with European Standard EN60825 (or IEC Publication 825)

For all areas

This equipment is classified as a class 1 level LASER product and there is no hazardous LASER radiation.

**Caution:**

- (1) Use of controls or adjustments or performance of procedures other than those specified herein may result in hazardous radiation exposure.
- (2) The drive is designed to be incorporated into a computer-based system or unit which has an enclosing cover. It should never be used as a stand alone drive.

**Danger:**

The serviceman should not remove the cover of drive unit and should not service because the drive unit is a non-serviceable part.

Please check DANGER label on PD-drive unit.

Unplug the AC power cord to the equipment before opening the top cover of the drive.

When the power switch it on, do not place your eyes close to the front panel door to look into the interior of the unit.

LASER Specification

Class 1 level LASER Product

Wave Length: DVD 658–8 nm

CD 775~815 nm

Laser safety information is appropriate only when drive with laser is installed.

## Safety precautions

1. Before servicing, unplug the power cord to prevent an electric shock.
2. When replacing parts, use only manufacture's recommended components for safety.
3. Check the condition of the power cord. Replace if wear or damage is evident.
4. After servicing, be sure to restore the lead dress, insulation barriers, insulation papers, shields, etc.

### Important Safety Instructions

When using your telephone equipment, basic safety precautions should always be followed to reduce the risk of fire, electric shock and injury to persons, including the following:

1. Do not use this product near water, for example, near a bath tub, wash bowl, kitchen sink or laundry tub, in a wet basement or near a swimming pool.
2. Avoid using a telephone (other than a cordless type) during an electrical storm. There may be a remote risk of electric shock from lightning.
3. Do not use the telephone to report a gas leak in the vicinity of the leak.
4. Use only the power cord and batteries indicated in this manual. Do not dispose of batteries in a fire. They may explode. Check with local codes for possible special disposal instructions.

SAVE THESE INSTRUCTIONS

#### LITHIUM BATTERY ⚠

• **CAUTION**

Danger of explosion if battery is incorrectly replaced.  
Replace only with the same or equivalent type recommended by the equipment manufacture.  
Discard used batteries according to the manufacturer's instructions.

#### LITHIUMBATTERIES ⚠

**Vorsicht!**

Explosionsgefahr bei unsachgemäßem Austausch der Batterie. Ersatz nur durch denselben oder einen vom Hersteller empfohlenen ähnlichen Typ. Entsorgung gebrauchter Batterien nach Angaben des Herstellers.

#### PILE AU LITHIUM ⚠

ATTENTION: IL Y A DANGER D'EXPLOSION S' IL Y A REMPLACEMENT INCORRECT DE LA PILE. REMPLACER UNIQUEMENT AVEC UNE PILE DU MÊME TYPE OU D'UN TYPE RECOMMANDÉ PAR LE CONSTRUCTEUR. METTRE AU RÉBUT LES PILES USAGÉES CONFORMÉMENT AUX INSTRUCTIONS DU FABRICANT.

### For U.S.A. / CANADA



A lithium ion battery that is recyclable powers the product you have purchased. Please call 1-800-8-BATTERY for information on how to recycle this battery.

L'appareil que vous vous êtes procuré est alimenté par une batterie au lithium-ion. Pour des renseignements sur le recyclage de la batterie, veuillez composer le 1-800-8-BATTERY.

### Lithium Battery

#### Lithium Battery!

This computer contains a lithium battery to enable the date, time, and other data to be stored. The battery should only be exchanged by authorized service personnel.

Warning! A risk of explosion from incorrect installation or mis-application may possibly occur.



## Precautions (Battery Pack)

- Care should be exercised with regard to the following in order to avoid the possibility of overheating, fire or damage.



### Avoid Heat

Do not throw the battery pack into a fire or expose it to excessive heat.



### Keep Articles Away

Do not place the battery pack together with articles such as necklaces or hairpins when carrying or storing.



### Do Not Disassemble

Do not insert sharp objects into the battery pack, expose it to bumps or shocks, deform, disassemble, or modify it.



### Do Not Short

Do not short the positive (+) and negative (-) contacts.



### Avoid Extreme Heat, Cold and Direct Sunlight

Do not charge, use or leave the battery pack for extended periods where it will be exposed to direct sunlight, in a hot place (in an automobile on a sunny day, for example), or in a cold place.



### Do Not Use With Any Other Computer

The battery pack is rechargeable and was intended for the specified computer or charger. Do not use it with a computer other than the one for which it was designed.



### Do Not Put into a Microwave

Do not put the battery pack into a microwave oven or a pressurized chamber.



### Discontinue Use

Should the battery emit an abnormal odor, become hot to the touch, become discolored, change shape, or become in any way different from normal, remove it from the computer or charger and discontinue use.

- Do not touch the terminals on the battery pack. The battery pack may no longer function properly if the contacts are dirty or damaged.
- Do not expose the battery pack to water, or allow it to become wet.

- If the battery pack will not be used for a long period of time (a month or more), charge or discharge (use) the battery pack until the remaining battery level becomes 30% to 40% and store it in a cool, dry place.
- This computer prevents overcharging of the battery by recharging only when the remaining power is less than approx. 95% of capacity.
- The battery pack is not charged when the computer is first purchased. Be sure to charge it before using it for the first time. When the AC adaptor is connected to the computer, charging begins automatically.
- Should the battery leak and the fluid get into your eyes, do not rub your eyes. Immediately flush your eyes with clear water and see a doctor for medical treatment as soon as possible.

## NOTE

- The battery pack may become warm during recharging or normal use. This is completely normal.
- Recharging will not commence outside of the allowable temperature range (0 °C to 50 °C {32°F to 122 °F}). (☞ Reference Manual “Battery Power”) Once the allowable range requirement is satisfied, charging begins automatically. Note that the recharging time varies based on the usage conditions. (Recharging takes longer than usual when the temperature is 10 °C {50 °F} or less.)
- If the temperature is low, the operating time is shortened. Only use the computer within the allowable temperature range.
- The battery pack is a consumable item. If the amount of time the computer can be run off a particular battery pack becomes dramatically shorter and repeated rechargings do not restore its performance, the battery pack should be replaced with a new one.
- When transporting spare batteries inside a package, briefcase, etc., it is recommended that it be placed in a plastic bag so that its contacts are protected.
- Always power off the computer when it is not in use. Leaving the computer on when the AC adaptor is not connected will exhaust the remaining battery capacity.

# CONTENTS

1. Specifications .....	7
2. Names and Functions of Parts.....	10
3. Block Diagram .....	12
4. Diagnosis Procedure .....	13
5. Power-On Self Test (Boot Check).....	15
6. List of Error Codes <Only when the port replicator is connected> .....	16
7. Self Diagnosis Test .....	18
8. Wiring Connection Diagram .....	23
9. Disassembly/Reassembly .....	24
10. Exploded View .....	80
11. Replacement Parts List .....	83

# 1 Specifications

## ■ Main Specifications

Model No.		CF-Y5LWVYZBM
CPU/ Secondary cache memory		Intel® Core™ Duo Processor Low Voltage L 2400 (1.66 GHz, 2 MB* <sup>1</sup> L2 cache, 667 MHz FSB)
Chip Set		Mobile Intel® 945 GMS Express chip set
Main Memory		512 MB* <sup>1</sup> , DDR2 SDRAM (1536 MB* <sup>1</sup> Max.)
Video Memory		UMA (128 MB* <sup>1</sup> Max.)* <sup>2</sup>
Hard Disk Drive		60 GB* <sup>3</sup>
CD/DVD Drive		USB 2.0 connection interface DVD MULTI Drive built-in, Buffer underrun error prevention function: Supported
Continuous Data Transfer Speed* <sup>4</sup> * <sup>5</sup>	Reading* <sup>6</sup>	●DVD-RAM* <sup>7</sup> : 2X (4.7 GB* <sup>3</sup> )/1X (2.6 GB* <sup>3</sup> ) ●DVD-R* <sup>8</sup> : 4X (Max.) ●DVD-RW: 4X (Max.) ●DVD-ROM: 8X (Max.) ●CD-ROM: 24X (Max.) ●CD-R: 24X (Max.) ●CD-RW: 20X (Max.) ●+R: 4X (Max.) ●+R DL: 4X (Max.) ●+RW: 4X (Max.)
	Writing* <sup>9</sup>	●DVD-RAM* <sup>7</sup> : 2X (4.7GB* <sup>3</sup> ) ●DVD-R: 1X/2X/4X ●DVD-RW: 1X/2X ●+R: 2.4X/4X ●+RW: 2.4X ●CD-R: 4X/8X/8-16X/8-24X ●CD-RW: 4X ●High-Speed CD-RW: 4X/8X/10X ●Ultra-Speed CD-RW: 8X/10X
Supported Disks/Format* <sup>5</sup>	Reading	●DVD-ROM (Single Layer, Dual Layer) ●DVD-Video ●DVD-R* <sup>8</sup> (1.4 GB, 3.95 GB, 4.7 GB)* <sup>3</sup> ●DVD-RW (Ver.1.1/1.2 1.4 GB, 4.7 GB, 9.4 GB)* <sup>3</sup> ●DVD-RAM* <sup>7</sup> (1.4 GB, 2.8 GB, 2.6 GB, 5.2 GB, 4.7 GB, 9.4 GB)* <sup>3</sup> ●+R (4.7 GB)* <sup>3</sup> ●+R DL (8.5 GB)* <sup>3</sup> ●+RW (4.7 GB)* <sup>3</sup> ●CD-Audio ●CD-ROM (XA compatible) ●CD-R ●Photo CD (multiple session compatible) ●Video CD ●CD-EXTRA ●CD-RW ●CD-TEXT
	Writing	●DVD-RAM* <sup>7</sup> (1.4GB, 2.8GB, 4.7GB, 9.4GB)* <sup>3</sup> ●DVD-R (1.4GB, 4.7GB for General)* <sup>3</sup> ●DVD-RW (Ver.1.1/1.2 4.7GB, 9.4GB)* <sup>3</sup> ●+R (4.7GB* <sup>3</sup> ) ●+RW (4.7GB* <sup>3</sup> ) ●CD-R ●CD-RW
Display Method		14.1 SXGA+ type (TFT) (1400 × 1050 dots)
Internal LCD		65,536/16,777,216 colors (1400 × 1050 dots)* <sup>10</sup>
External Display* <sup>11</sup>		65,536/16,777,216 colors (800 × 600 dots/1024 × 768 dots/1280 × 768 dots/1280 × 1024 dots/1400 × 1050 dots/1600 × 1200 dots/2048 × 1536 dots (60 Hz)* <sup>12</sup> )
Simultaneous Display on LCD + External Display* <sup>11</sup>		65,536/16,777,216 colors (800 × 600 dots/1024 × 768 dots/1280 × 768 dots/1280 × 1024 dots/1400 × 1050 dots)* <sup>10</sup>
Wireless LAN		Intel® PRO/Wireless 3945 ABG Network Connection (next page)
Bluetooth™		(next page)
LAN* <sup>13</sup>		IEEE 802.3 10Base-T, IEEE 802.3u 100Base-TX
Modem		Data: 56 kbps (V.92) FAX: 14.4 kbps
Sound		WAVE and MIDI playback, Intel® High Definition Audio subsystem support, Stereo Speakers (built in)
Security Chip		TPM (TCG V1.2 compliant)* <sup>14</sup>
Card Slots	PC Card Slot	× 1, Type I or Type II, Allowable current 3.3 V: 400 mA, 5 V: 400 mA
	SD Memory Card Slot* <sup>15</sup>	× 1, Data transfer rate = 8 MB per second
RAM Module Slot		× 1, DDR2 SDRAM, 172-pin, 1.8 V, Micro DIMM, PC2-4200 Compliant* <sup>16</sup>
Interface		USB Ports × 2 (USB2.0 × 2)* <sup>17</sup> / Modem Port (RJ-11) / LAN Port (RJ-45) * <sup>13</sup> / External Display Port: Mini Dsub 15-pin female / Microphone Jack: Miniature jack, 3.5 DIA / Headphone Jack: Miniature jack, 3.5 DIA / Mini Port Replicator connector: Dedicated 50-pin male
Keyboard/Pointing Device		87 keys/Touch Pad
Power Supply		AC adaptor or Battery pack
AC Adaptor* <sup>18</sup>		Input: 100 V - 240 V AC, 50 Hz/60 Hz Output: 16 V DC, 3.75 A
Battery Pack		Li-ion 10.65 V, 5.7 Ah
Operating Time* <sup>19</sup>		Approx. 5 hours - 8 hours* <sup>20</sup> (Approx. 6 hours* <sup>21</sup> ) (Disable Economy Mode (ECO))
Charging Time* <sup>22</sup>		Approx. 5 hours (Power off)/Approx. 6.5 hours (Power on)

Model No.			CF-Y5LWVYZBM
Power Consumption <sup>*23</sup>			Approx. 35 W <sup>*24</sup> / Approx. 60 W (maximum when recharging in the ON state)
Physical Dimensions (W × H × D)			309.6 mm × 28 mm (at the front)/44.5 mm (at the rear) × 245.5 mm (excluding protrusion) {12.2 " × 1.1 " / 1.8 " × 10.0 "}
Weight <sup>*25</sup>			Approx. 1530 g {3.4 lb.}
Environment	Operation	Temperature	5°C to 35°C {41°F to 95°F}
		Humidity	30% to 80% RH (No condensation)
	Storage	Temperature	-20°C to 60°C {-4°F to 140°F}
		Humidity	30% to 90% RH (No condensation)
OS <sup>*26</sup>			Microsoft® Windows® XP Professional Service Pack 2 with Advanced Security Technologies (NTFS File system)
Pre-installed Software <sup>*26</sup>			Microsoft® Internet Explorer 6 Service Pack 2 / DirectX 9.0c / Microsoft® Windows® Media Player 10 / Microsoft® Windows® Movie Maker 2.1 / Microsoft® .NET Framework 1.1 SP1/2.0 / Adobe Reader / Intel® PROSet/Wireless Software <Only for model with wireless LAN> / SD Utility / Icon Enlarger / Loupe Utility / Touch Pad Utility / DMI Viewer / PC Information Viewer / WinDVD 5 (OEM Version) / B's Recorder GOLD8 BASIC / B's CLiP 6 <sup>*27</sup> / Hotkey Settings / Optical Disc Drive Letter-Setting Utility / Optical Disc Drive Power-Saving Utility / Wireless Switch Utility <Only for model with wireless LAN/Bluetooth> / Economy Mode (ECO) Setting Utility / Battery Recalibration Utility / Infineon TPM Professional Package V2.5 <sup>*28</sup> / Recover Pro 6 <sup>*28</sup>
			Setup Utility / Hard Disk Data Erase Utility <sup>*29</sup> / PC-Diagnostic Utility <sup>*30</sup>

### ■ Wireless LAN

Data Transfer Rates	IEEE802.11a: 54/48/36/24/18/12/9/6 Mbps (automatically switched) <sup>*31</sup> IEEE802.11b: 11/5.5/2/1 Mbps (automatically switched) <sup>*31</sup> IEEE802.11g: 54/48/36/24/18/12/9/6 Mbps (automatically switched) <sup>*31</sup>
Standard Supported	IEEE802.11a/IEEE802.11b/IEEE802.11g
Transmission Method	OFDM system, DS-SS system
Wireless Channels Used	IEEE802.11a: Channels 36/40/44/48/52/56/60/64/149/153/157/161/165 IEEE802.11b/ IEEE802.11g: Channels 1 to 11
RF Frequency Band	IEEE802.11a: 5.18 - 5.32 GHz, 5.745 - 5.825 GHz IEEE802.11b/ IEEE802.11g: 2412 - 2462 MHz

### ■ Bluetooth™

Bluetooth Version	2.0 + EDR
Transmission Method	FHSS system
Wireless Channels Used	Channels 1 to 79
RF Frequency Band	2.402-2.48 GHz
Power Class	Class 1

\*1 1 MB = 1,048,576 bytes

\*2 A segment of the main memory is allotted automatically depending on the computer's operating status. The size of the Video Memory cannot be set by the user.

\*3 1 GB = 1,000,000,000 bytes. Your operating system or some application software will report as fewer GB.

\*4 Data transfer speeds indicate values measured by Matsushita Electric Industrial Co., Ltd. The data transfer rate of DVD per 1X speed is 1,350 KB/s. The data transfer rate of CD per 1X speed is 150 KB/s.

\*5 Performance of CD-R, CD-RW, DVD-RAM, DVD-R, DVD-RW, +R, +R DL, and +RW cannot be guaranteed depending on writing status and recording format. Also, some data cannot be played back depending on the disk, settings, and environment being used.  
Does not support writing to DVD-R DL/+R DL (dual layer disks) or reading from DVD-R DL.

\*6 If an unbalanced disk (e.g., a disk with which the balance has been displaced from the center) is inserted, the speed may become slower if there are large vibrations while the disk is rotating.

\*7 Only non-cartridge type or removable cartridge type can be used.

When writing to DVD-RAM, use only disks up to 3x. This application cannot be used with 5x DVD-RAM media (2-5x disks, etc.).

\*8 DVD-R is compatible with 4.7 GB (for General) playback. DVD-R (for Authoring) playback is compatible with disks recorded using Disk-at-Once recording.

\*9 Depending on the disk, the writing speed may become slower.

\*10 A 16,777,216 color display is achieved by using the dithering function.

\*11 Display may be impossible using some connected external displays.

- \*12 When using an external display with a resolution of 2048 x 1536 dots, use a display that supports a 60Hz refresh rate. If an external display that does not support a 60Hz refresh rate is used, images may not be displayed properly.
- \*13 Some devices cannot be used depending on the port type.
- \*14 For information on TPM, click [start] - [Run] and input "c:\util\drivers\tpm\README.pdf", and refer to the *Installation Manual* of "Trusted Platform Module (TPM)".
- \*15 Operation has been tested and confirmed using Panasonic SD Memory Cards with a capacity of up to 2 GB. The transfer rate using the SD Memory Card slot on this computer is 8 MB per second. (This is a theoretical value, and differs from actual speeds.)  
The transfer rate is 8 MB per second even if you use an SD Memory Card that supports high-speed transfer rates. Operation on other SD equipment is not guaranteed. This computer is not compatible with MultiMediaCards or SDHC Memory Cards.  
Do not insert these kinds of cards.
- \*16 Only a RAM module designed for DDR2 (PC2-4200) can be added (Panasonic : CF-BAW0512U, CF-BAW1024U). JEDEC standard 214 pin Micro DIMM cannot be used. PC2100 / PC2700 172 pin Micro DIMM cannot be used. If a PC2-3200 RAM module is installed, the main memory processing speed may become slower.
- \*17 Does not guarantee operation of all USB-compatible peripherals.
- \*18 <Only for North America>  
The AC adaptor is compatible with power sources up to 240 V AC adaptor. This computer is supplied with a 125 V AC compatible AC cord.
- \*19 Varies depending on the usage conditions, or when an optional device is attached. Measured when the power saving function on the USB2.0 USB Root Hub is set to on. (At the time of purchase, the power saving function is activated.) When Economy Mode (ECO) is enabled, the operating time becomes approximately 20% shorter than when it is disabled.
- \*20 Measured using BatteryMark™ Version 4.0.1 (LCD brightness : Maximum - Minimum).
- \*21 Measured using MobileMark™ 2005 (LCD brightness : 60 cd/m<sup>2</sup>).
- \*22 Varies depending on the usage conditions, CPU speed, etc. It may take a long time to charge a fully discharged battery.
- \*23 Approx. 1.5 W when the battery pack is fully charged (or not being charged) and the computer is off.
- \*24 Rated power consumption.
- 23-E-1
- \*25 Average value. May differ depending on models.
- \*26 Operations of this computer are not guaranteed except for the pre-installed OS.
- \*27 Preinstalled B's CLiP does not support CD-R, DVD-R, +R and DVD-RAM.
- \*28 Must be installed before use.
- \*29 The Product Recovery DVD-ROM is required.
- \*30 For startup methods, refer to "Hardware Diagnostics".
- \*31 These are speeds specified in IEEE802.11a+b+g standards. Actual speeds may differ.

20-M-2-1

## 2 Names and Functions of Parts

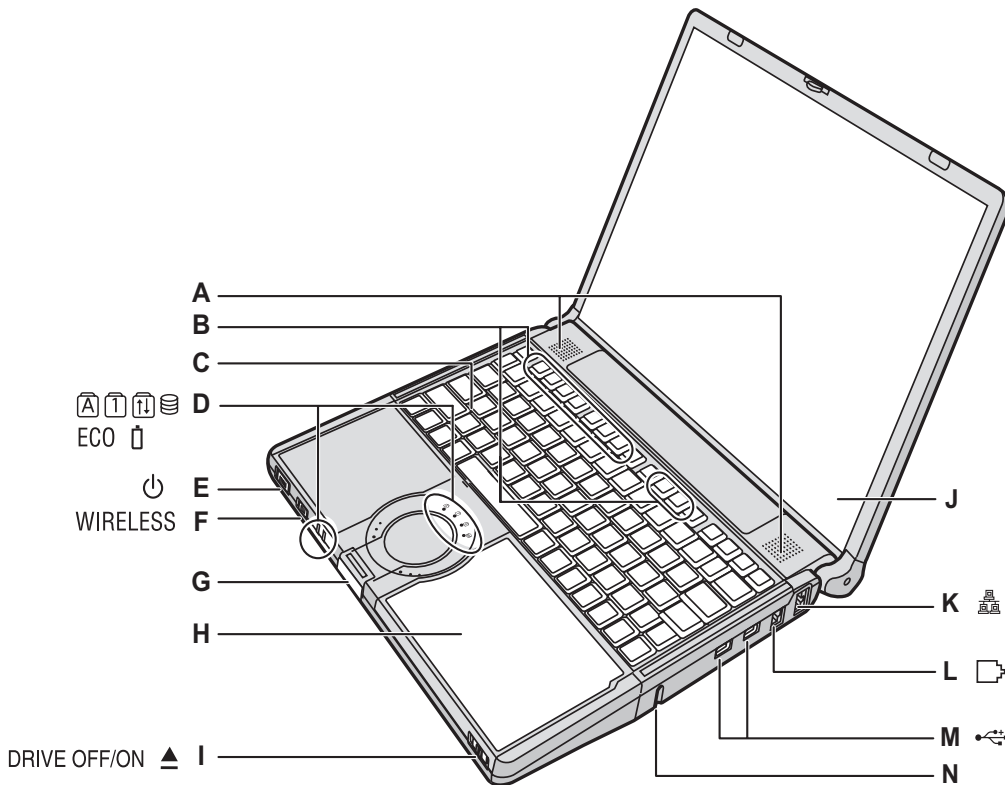

**A : Speakers**

**B : Function Key**

**C : Keyboard**

**D : LED Indicator**

: Caps lock

: Numeric key (NumLk)

: Scroll lock (ScrLk)

: Hard disk drive status

ECO : Economy Mode (ECO) status

: Battery status

**E : Power Switch**

**Power Indicator**

- Off: Power off/Hibernation
- Green: Power on
- Blinking green: Standby

**F : Wireless Switch**

<Only for model with wireless LAN/Bluetooth>

“Wireless LAN”

**G : Latch**

When closing the display, press down firmly from above until the latch is firmly closed (locked).

**CAUTION**

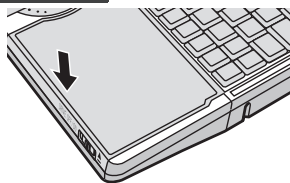

When closing the disk cover, press down near the drive power/open switch (position of the arrow) to ensure that the cover is locked.

**H : CD/DVD Drive**

**I : CD/DVD Drive Power/Open Switch**

- Slide the switch to the right to open the disk cover.
- Slide the switch to the left to turn on/off the drive power.

**CD/DVD Drive Indicator**

- Off: Drive power is off.
- Green: Drive power is on, but the drive is not accessed.
- Blinking green: Drive power is on, and the drive is being accessed.

**J : LCD**

**K : LAN Port**

If the Mini Port Replicator is connected to the computer, connect the LAN cable to the LAN port on the Mini Port Replicator. You cannot use the LAN port on the computer.

**L : Modem Port**

- Be sure to use the included modem telephone cable, and insert the ferrite core side of modem telephone cable into the modem port on the computer.
- Do not move/remove the ferrite core of modem telephone cable.

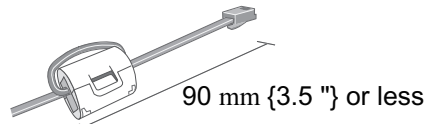

**M : USB Ports**

**N : Security Lock**

You can connect a Kensington cable. Refer to the instruction manual of the cable. The security lock and cable is a theft prevention device. Matsushita Electric Industrial Co., Ltd. will bear no responsibility in the event of theft.

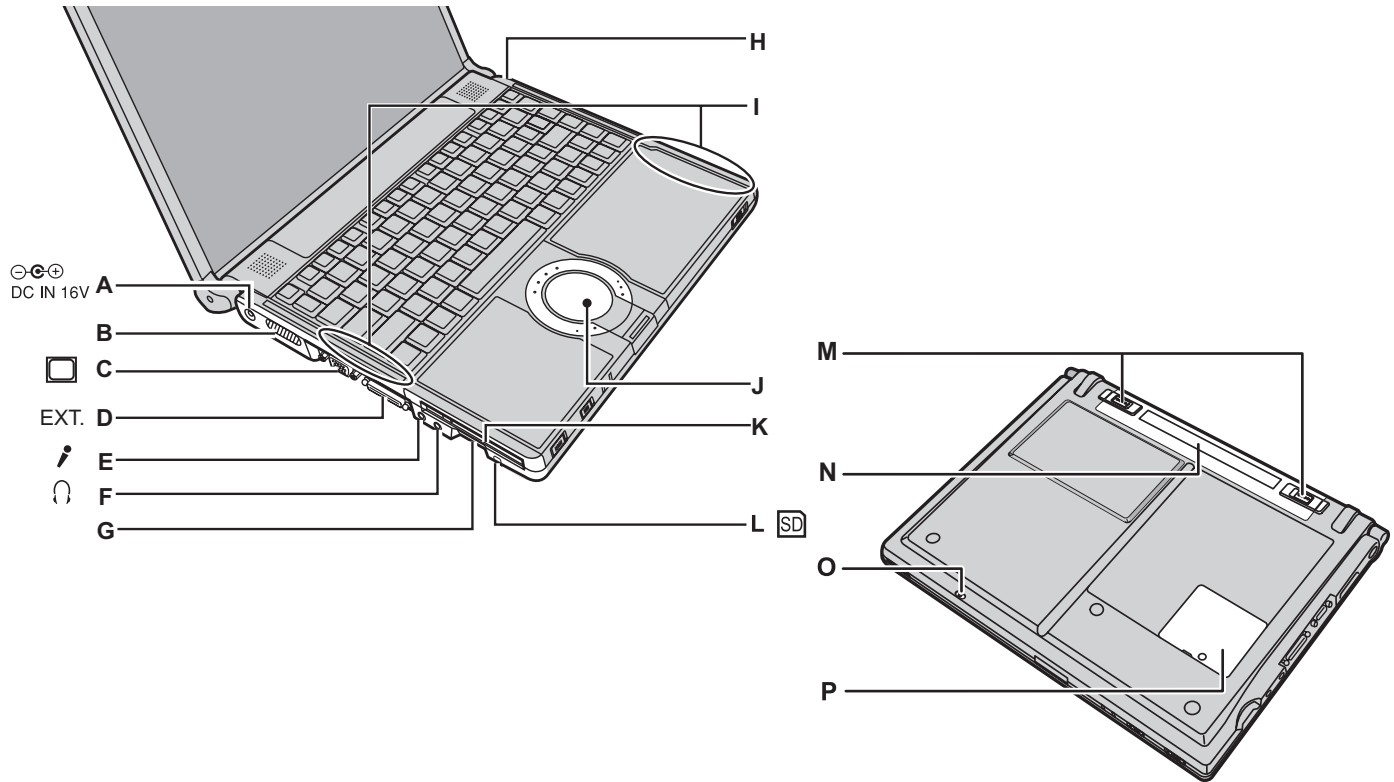

**A : DC-IN Jack**

**B : Ventilation Hole**

**C : External Display Port**

If the Mini Port Replicator is connected to the computer, connect the external display to the external display port on the Mini Port Replicator. You cannot use the external display port on the computer.

**D : Mini Port Replicator Connector**

Connect the Mini Port Replicator (optional).

**E : Microphone Jack**

A condenser microphone can be used. If other types of microphones are used, audio input may not be possible, or malfunctions may occur as a result.

- When recording in stereo using a stereo microphone

Double-click  in the notification area, click [Options] - [Properties], and add a check mark for [Recording], click [OK] - [Options] - [Advanced Controls] - [Advanced], remove a check mark for [Mono Microphone], and then click [Close].

- When using a monaural microphone with a 2-terminal plug  
With the settings outlined above, only audio on the left track will be recorded.

When monitoring the microphone audio using headphones, sounds on the left track cannot be heard, regardless of the above settings. This is a result of the computer's specifications, and is not a malfunction.

**F : Headphone Jack**

You can connect headphones or amplified speakers. When they are connected, audio from the internal speakers is not heard.

**G : SD Memory Card Slot**

**H : Bluetooth Antenna**

<Only for model with Bluetooth>

**I : Wireless LAN Antenna**

**J : Touch Pad**

**K : PC Card Slot**

**L : SD Memory Card Indicator**

Blinking: During access

**M : Battery Latches**

**N : Battery Pack**

**O : Emergency Hole**

**P : RAM Module Slot**

# 3 Block Diagram

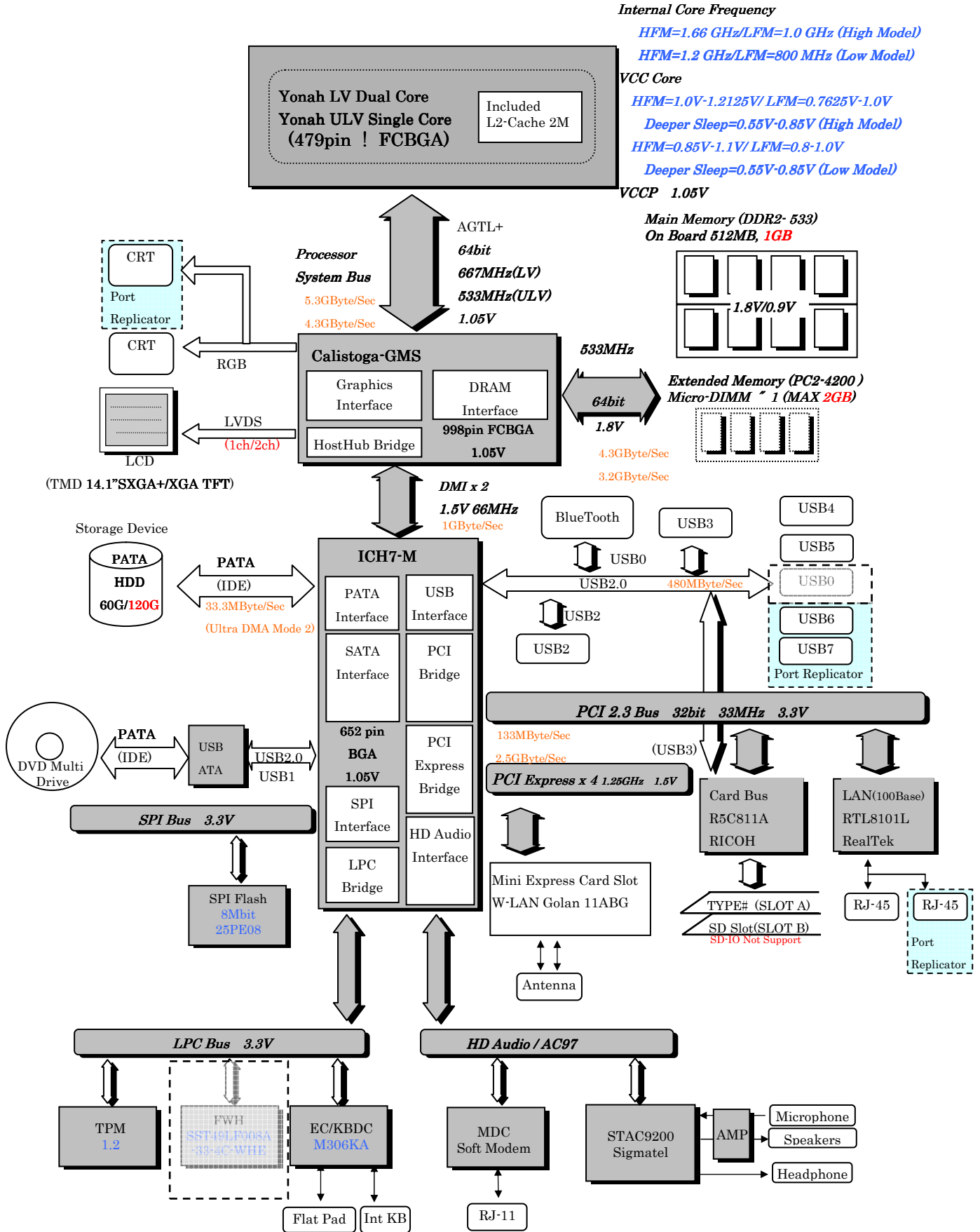



# 4 Diagnosis Procedure

## 4.1. Basic Procedures

The basic procedures for diagnosis, disassembly, and test of defective parts of a set to be repaired are summarized below. For details, refer to relevant pages in the Service Manual.

● Flow Chart

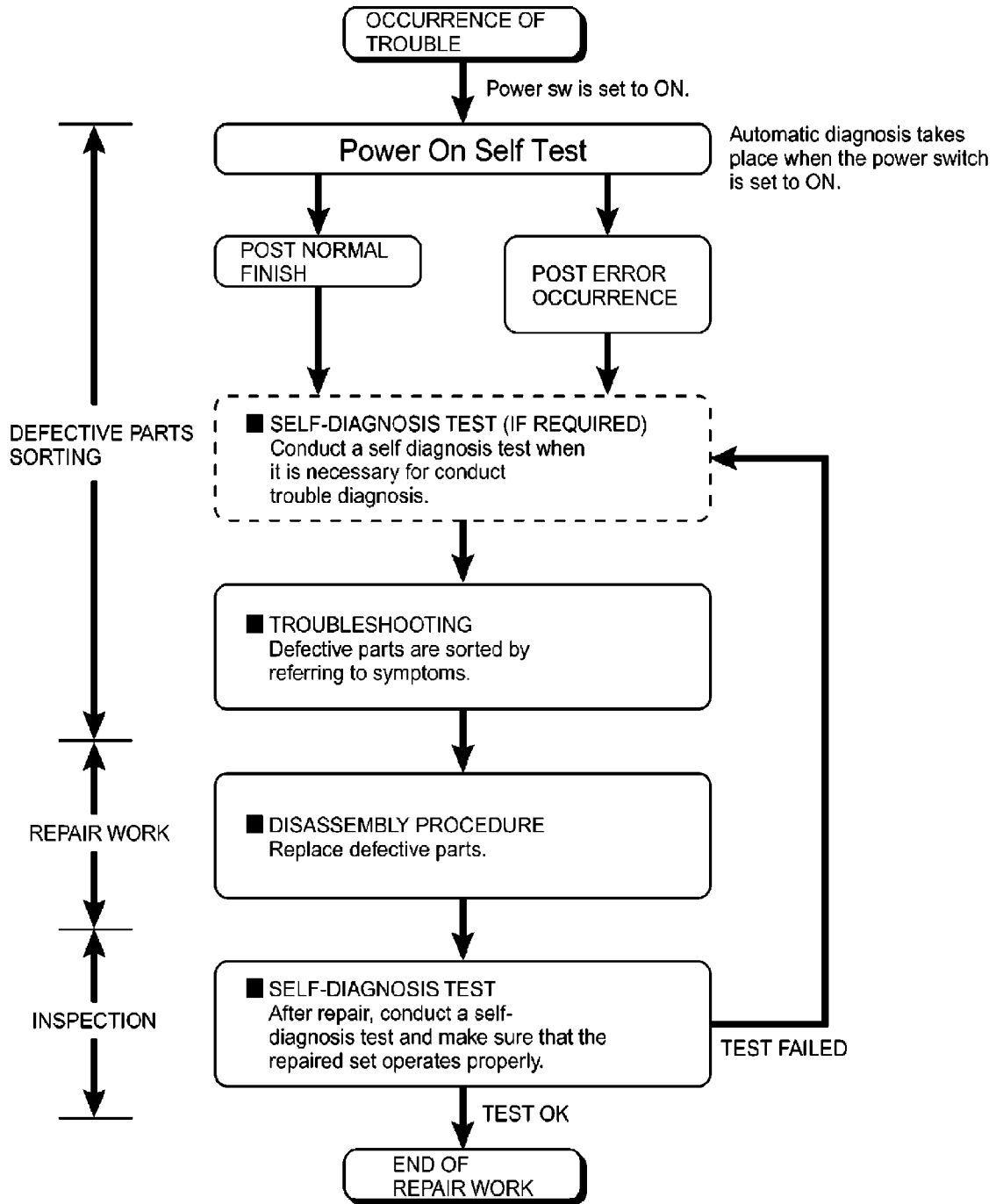

## 4.2. Troubleshooting

Please take note of the following two points with regard to troubleshooting:

1. Know-how of diagnosis upon occurrence of heavy troubles, e.g. Set cannot be turned ON, Set fails to start, No display on screen, etc.
2. Explanation of each trouble, mainly symptom of trouble in operation.

### Flow Chart

START

Pay attention to the following points when in pursuit of the cause of a troubleshooting.  
 1. Peripheral apparatus connected with the set should all be removed before operation check.  
 2. Make sure that cables, boards, etc. are not coming off, and recheck the contact condition.

Set cannot be supplied with current.  
Power lamp fails to light up.

AC Adaptor/Battery Output voltage

NG

Replace AC Adaptor/Battery

OK

Power lamp check

NO

Check contact condition of power input terminal. Replace if defective.  
Check Power SW. Replace if defective.

YES

Dark display on screen.  
Screen fails to display.

Inverter board

NG

Replace inverter board.  
Check inverter cable continuity. Replace if defective

OK

LCD back light lighting

NO

Replace LCD back light.

YES

LCD unit check

NG

Replace LCD unit.

OK

Failure in starting

BIOS operation check

NO

Replace main board (Check fuse at power source).

YES

Result of POST

NG

Refer to POST error code table.

Replace main board.

OK

Set-up utility starting

NG

Replace main board.

OK

Return set-up utility setpoint to the state of delivery from factory.

Heavy trouble e.g.,  
Set cannot be turned ON,  
Set fails to start,  
No display on screen, etc.

HDD access

NO

Check HDD cable connection and continuity.  
Replace if defective.  
Replace HDD & Reinstall.  
Replace main board.

YES

Not displayed properly on screen.

Main board check

NG

Replace main board

OK

Some or all keys cannot be input.

Make sure of contact of K/B connector in use.  
Replace keyboard or main board.

DVD/CD CALL not practicable.

Trouble symptoms on some of DVD or CD

NO

Check if there are any flaws on DVD or CD media. Since flaws may appear on specific media, DVD or CD media can be defective.

YES

Replace DVD drive.  
Replace main board.

\*Clean DVD-ROM drive with an applicator.

Starts but operates unstably.

Reinstall HDD.  
Replace main board.

END

Each kind of trouble in operation.

# 5 Power-On Self Test (Boot Check)

## Outline of POST

The set has a boot check function called POST (Power-On Self Test) in it.

The condition of the main body is diagnosed by checking beep sound or error code.

Start .....Test begins automatically when power switch is set to ON.

Normal finish .....After memory checking, a beep sound is issued once and the set is placed into automatic stop.

Note: If no error occurs, nothing is displayed. (No display of OK, etc.)

### Error Diagnosis by Checking Beep Signal Sound

The beep sound is as follows:



(Length of bar shows length of sound.)

■ = long sound (about 0.4 sec.), ■ = short sound (about 0.2 sec.), Length between sounds is about 0.1 sec.

**Table of errors classified by beep sounds**

Diagnosis	Beep signal sound	Error message
Main board	1(long sound)-2	BIOS ROM error
	1-2-2-3	BIOS ROM error
	1-3-1-1	RAM error
	1-3-1-3	Keyboard controller error
	1-3-4-1	RAM error
	1-3-4-3	RAM error
	1-4-1-1	RAM error
	2-1-2-3	BIOS ROM error
	2-2-3-1	Occurrence of unexpected offering

(Note) A beep sound is also issued in case of other I/O trouble.

## 6 List of Error Codes <Only when the port replicator is connected>

The following is a list of the messages that BIOS can display. Most of them occur during POST. Some of them display information about a hardware device, e.g., the amount of memory installed. Others may indicate a problem with a device, such as the way it has been configured. Following the list are explanations of the messages and remedies for reported problems. If your system displays one of except the messages marked below with an asterisk (\*), write down the message and contact Panasonic Technical Support. If your system fails after you make changes in the Setup menus, reset the computer, enter Setup and install Setup defaults or correct the error.

### **0200 Failure Fixed Disk**

Fixed disk in not working or not configured properly. Check to see if fixed disk is attached properly. Run Setup. Find out if the fixed-disk type is correctly identified.

### **0210 Stuck key**

Stuck key on keyboard.

### **0211 Keyboard error**

Keyboard not working.

### **0212 Keyboard Controller Failed**

Keyboard controller failed test. May require replacing keyboard controller.

### **0213 Keyboard locked - Unlock key switch**

Unlock the system to proceed.

### **0230 System RAM Failed at offset : *nnnn***

System RAM failed at offset *nnnn* of in the 64k block at which the error was detected.

### **0231 Shadow RAM Failed at offset : *nnnn***

Shadow RAM failed at offset *nnnn* of the 64k block at which the error was detected.

### **0232 Extended RAM Failed at offset : *nnnn***

Extended memory not working or not configured properly at offset *nnnn*.

### **0250 System battery is dead - Replace and run SETUP**

The CMOS clock battery indicator shows the battery is dead. Replace the battery and run Setup to reconfigure the system.

### **\*0251 System CMOS checksum bad - Default configuration used**

System CMOS has been corrupted or modified incorrectly, perhaps by an application program that changes data stored in CMOS. The BIOS installed Default SETUP Values. If you do not want these values, enter Setup and enter your own values. If the error persists, check the system battery or contact Panasonic Technical Support.

### **0260 System timer error**

The timer test failed. Requires repair of system board.

### **0270 Real time clock error**

Real-time clock fails BIOS test. May require board repair.

### **\*0280 Previous boot incomplete - Default configuration used**

Previous POST did not complete successfully. POST loads default values and offers to run Setup. If the failure was caused by incorrect values and they are not corrected, the next boot will likely fail. On systems with control of **wait states**, improper Setup settings can also terminate POST and cause this error on the next boot. Run Setup and verify that the wait-state configuration is correct. This error is cleared the next time the system is booted.

### **0281 Memory Size found by POST differed from EISA CMOS**

Memory size found by POST differed from EISA CMOS.

**02D0 System cache error - Cache disabled**

Contact Panasonic Technical Support.

**02F0: CPU ID:**

CPU socket number for Multi-Processor error.

**02F4: EISA CMOS not writable**

ServerBIOS2 test error: Cannot write to EISA CMOS.

**02F5: DMA Test Failed**

ServerBIOS2 test error: Cannot write to extended DMA (Direct Memory Access) registers.

**02F6: Software NMI Failed**

ServerBIOS2 test error: Cannot generate software NMI (Non-Maskable Interrupt).

**02F7: Fail - Safe Timer NMI Failed**

ServerBIOS2 test error: Fail-Safe Timer takes too long.

***device* address Conflict**

Address conflict for specified *device*.

**Allocation Error for: *device***

Run ISA or EISA Configuration Utility to resolve resource conflict for the specified *device*.

**Failing Bits : *nnnn***

The hex number *nnnn* is a map of the bits at the RAM address which failed the memory test. Each 1 (one) in the map indicates a failed bit. See error 230,231 or 232 for offset address of the failure in System, Extended or Shadow memory.

**Invalid System Configuration Data**

Problem with NVRAM (CMOS) data.

**I/O device IRQ conflict**

I/O device IRQ conflict error.

**Operating System not found**

Operating system cannot be located on either drive A: or drive C:. Enter Setup and see if fixed disk and drive A: are properly identified.

**Parity Check 1 *nnnn***

Parity error found in the system bus. BIOS attempts to locate the address and display it on the screen. If it cannot locate the address, it displays ????. Parity is a method for checking errors in binary data. A parity error indicates that some data has been corrupted.

**Parity Check 2 *nnnn***

Parity error found in the I/O bus. BIOS attempts to locate the address and display it on the screen. If it cannot locate the address, it displays ????.

**Press <F1> to resume, <F2> to Setup**

Displayed after any recoverable error message. Press <F1> to start the boot process or <F2> to enter a Setup and change the settings. Write down and follow the information shown on the screen.

# 7 Self Diagnosis Test

As for the self-diagnosis test(PC-Diagnostic utility) to use this model, a standard test and the enhancing test by the module of the main body building in are possible.

- Notes To skip BIOS password  
Use <Ctrl>+<F10> key to skip BIOS password or authentication of fingerprint.  
This key is only for entering DIAG mode. Not available to boot the computer.  
If customer set "HDD Lock", the DIAG program cannot perform HDD test.  
\*This key is for service purpose only. Do not disclose this information to unrelated others.

## 1. Beginning of self-diagnosis test

### 1-1. Setting of content of setup

1. The power supply of the computer is turned on.
2. " F2 " is pushed on the screen of "Panasonic" while " press <F2 to enter Setup> " is displayed.
3. The setup utility starts and then takes notes of the content of the BIOS setup of present set.
4. " F9 " is pushed, " Yes" is selected on the screen of " Is the default value loaded? ", and " Enter" is pushed.
5. " F10 " is pushed.
6. " Yes" is selected on the screen of the setup confirmation, and " Enter" is pushed.
7. The computer starts automatically.

#### Attention

- If the device which can be set is set to "Invalidity" by "Advanced" or "Security" menu, becomes an error by "PC-Diagnostic utility".  
(It is judged that the device which can be set to "Invalidity" by "Main" menu such as "Flat pad" is normal if the controller operates normally though sets to "Invalidity" by the setup. )
- In the model with built-in DVD of the USB connection, even if DVD is normal, becomes an error if legacy USB is set to "Invalidity"

### 1-2. When you execute an automatic test

1. "Ctrl" + "F7" is pushed while the "Panasonic" start screen is displayed after the computer is started.
2. The test of all devices begins automatically by "PC-Diagnostic utility"s starting.

#### Attention

- It is a test which the customer who bought PC can execute. (As for HDD, the enhancing test is also possible.)
- A flat pad does not work for a while after starting "PC-Diagnostic utility".
- The movement of a flat pad might become abnormal If after RAM begins from the CPU/System test, a flat pad will be operated in about 30 seconds. In that case, restarts pushing "Alt" + "Ctrl" + "Del" key. Or, please start "PC-Diagnostic utility" again after doing the power supply switch in the slide, and turning off the power supply.

### 1-3. When you execute the enhancing test

1. Please let me discontinue diagnosing clicking  to end an automatic test.
2. Please click on the character of "D" "PC-Diagnostic utility" on the screen while pushing both of right "Shift" and left "Shift" keys.



3. All devices which can select the enhancing test make the setting of the enhancing test possible.
4. The district device is made "FULL" display (enhancing test).
5. The test begins clicking .

\*Please refer to item 4 for the error result of each test and the division of the breakdown part.

## 2. Operation of PC-Diagnostic Utility

- Only the device which can be inspected on the entire screen is displayed.
- The item does not appear when the device of wireless LAN etc. is not physically connected.
- The movement of the item must use an arrow key or a flat pad.

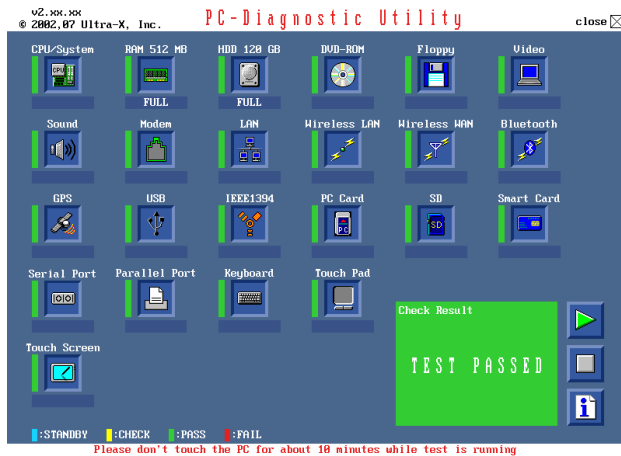



- As for the device under the diagnosis, blue and yellow are alternately displayed at the left of the icon.
- The diagnosis result of the device greens at the left of the icon when it is normal, and becomes red when abnormal.



- When the test of all devices ends, the test result is displayed under the right of the screen.



- Please click  while diagnosing when being stop on the way by the time the test of all devices ends.
- Please click  when you restart "PC-Diagnostic utility".

\*Each device is tested from the beginning, and it is not possible to restart on the way.

## 2-1. Selection of tested device

- To test only a specific device, "Test" and "Do not test" of each device can be selected.
- The device which can select the enhancing test changes in order of "The standard is tested" and "Do not test" whenever the device icon is clicked.



Start the standard test



Do not test

Please begin testing clicking  if the selection of the tested device ends.

## 2-2. "PC-Diagnostic utility" End method

When  of "Close" on the right of the screen is clicked, the computer reactivates automatically. Or, the power supply switch is done in the slide and the power supply is turned off.

## 2-3. The content of the setup is returned to the setting of the user

1. Turned on the computer.
2. "F2" is pushed on the screen while "Press<F2>to enter Setup" is displayed of "Panasonic".
3. Push "F10", and on the screen of "Is the change in the setting preserved and do end?"and then "Yes" is selected, and "Enter" is pushed.
4. The computer reactivates automatically.
5. The end option is chosen by the start menu, and the power supply of the computer is turned off.

Standard at test time

All devices other than RAM and HDD ----- about 1 minute

RAM standard test ----- 1 - 2 minutes

HDD standard test ----- 2 - 3 minutes

HDD enhancing test (60GB) ----- about 40 minutes

Ex.The standard when the standard <all device> is tested becomes  $1+2+3=6$  minutes.

- There is greatly a difference from RAM test when the memory is increased according to the performance of the memory occasionally.
- Moreover, when the main body of PC under the test is a high temperature, it occasionally takes time.
- There is greatly a difference from HDD according to the performance of the drive occasionally.



## 7.1. Test Item and Division of trouble

Test item	Standard	Enhancing	Content of standard test	Content of enhancing test	Place with possibility of breakdown
CPU / SYSTEM	○	—	CPU is shifted to protected mode, and "Violation of the paging", "Operation of the violation of a privileged instruction", and DMA, INT, TIMER, and the RTC operation are confirmed.	—	CPU / Main board
RAM	○	—	All memory space is tested in a special memory access pattern based on "R.S.T. technology".	—	Memory / Mainboard
HDD	○	○	The record area frequently accessed with Microsoft Windows XP to test in about two minutes regardless of points of HDD is emphatically tested.	All record area is tested.	HDD / Mainboard / Cable / Connector
MODEM	○	—	It is confirmed not to find abnormality in the AC97 modem controller.	—	MODEM/ Mainboard
Wireless LAN	○	—	It is confirmed not to find abnormality in the Wireless LAN modem controller.	—	Wireless LAN board / Connector / Mainboard
Sound *5	○	—			
USB	○	○ <sup>*1</sup>	It is confirmed not to find abnormality in the USB controller.	It is confirmed not to find abnormality in the wiring between the USB controller and the connector by confirming the connection of the USB equipment connected with the USB connector.	Mainboard / Connector
LAN	○	○ <sup>*2</sup>	It is confirmed not to find abnormality in the LAN controller.	It is confirmed not to find abnormality in the wiring between the controller and the connector by connecting to HUB with LAN cable.	Mainboard / Connector
PC Card	○	—	It is confirmed not to find abnormality in the CardBus controller.	—	Mainboard
SD	○	—	It is confirmed not to find abnormality in the SD controller.	—	Mainboard
Keyboard	○	○ <sup>*3</sup>	It is confirmed not to find abnormality in keyboard controller's keyboard interface.	The key is actually input, and the operation is displayed on the screen.	Mainboard / Keyboard
Touch Pad	○	○ <sup>*4</sup>	Whether keyboard controller's mouse interface operates normally is confirmed.	The operation is actually displayed on the screen by operating the touch pad.	Mainboard / Touch Pad
DVD-ROM	○	○ <sup>*6</sup>	The drive is normally reset, and it is accessible is confirmed.	It is confirmed to be able to read media normally.	Mainboard / Touch Pad

Test Item	Standard	Enhanced	Content of Standard Test	Content of Extend Test	The place with possibility of breakdown
Touch Screen	○	○	It is confirmed not to find abnormality in the USB connection of Touch Screen. This test cannot find abnormality of Touch Screen.	Perform Touch Screen functionality practically. Operator has to judge PASS/FAIL with test result.	Main board/ Touch Screen
Bluetooth	○		It is confirmed not to find abnormality in the connection of Main board and Bluetooth module.	—	Bluetooth cable
Floppy	○	—	It is confirmed not to find abnormality in the legacy FD drive. This test cannot find abnormality of mechanical breakdown. (e.g.. Head, Motor)	—	FD Drive/ Main board (Super I/O)/ FDD cable FDD connector
Video	○	—	It is confirmed not to find abnormality in access to VRAM with VESA. The PC which uses main of Main board and GPS main memory failure.	—	Main board (Chipset, Graphic Controller)/ Memory
GPS	○	—	It is confirmed not to find abnormality in the connection memory as VRAM may fail with	—	GPS cable
IEEE1394	○	—	It is confirmed not to find abnormality in the IEEE1394 controller.	—	Main board (IEEE 1394 Controller)
Express Card	—	○	—	It is confirmed not to find abnormality in the wiring between Chipset and Express Card.	Main board (Chipset)/ Express Card Connector
Smart Card	○	—	It is confirmed not to find abnormality in the Smart Card controller.	—	Main board (Smart Card Controller)
Serial Port	○	○ *7	It is confirmed not to find abnormality of Super I/O UART function. This test cannot find lack of wiring between Super I/O and Serial Connector.	It is confirmed not to find abnormality in the wiring between Super I/O and Serial Connector. This test cannot find failure of cable characteristic and device problems.	Main board (Super I/O)/ Serial Connector
Parallel Port	○	○ *8	It is confirmed not to find abnormality of Super I/O parallel function. This test cannot find lack of wiring between Super I/O and Parallel Connector.	It is confirmed not to find abnormality in the wiring between Super I/O and Parallel Connector. This test cannot find failure of cable characteristic and device problems.	Main board (Super I/O)/ Parallel Connector

\*1 Please connect the USB device with the port (USB connector) which wants to test before the tests.

\*2 Please connect LAN port with LAN HUB with LAN cable before the tests.

\*3 The operator actually inputs the key, and the operator judges PASS/FAIL of the test.

\*4 The operator actually operates the mouse, and the operator judges PASS/FAIL of the test.

\*5 It is not abnormal though the sound is emitted from the speaker while testing.

※ When the test result is PASS, trouble is thought by not hearing of the sound under the test from the speaker and the headphone by the wiring of the audio output system.

\*6 Please set DVD/CD media in the drive before the tests.

\*7 Please set a Special Loop Back Connector Tool at serial connector for Enhanced Test. (This Connector Tool is same as the one used before.)

\*8 Please set a Special Loop Back Connector Tool at parallel connector for Enhanced Test. (This Connector Tools is same as the one used before.)

# 8 Wiring Connection Diagram

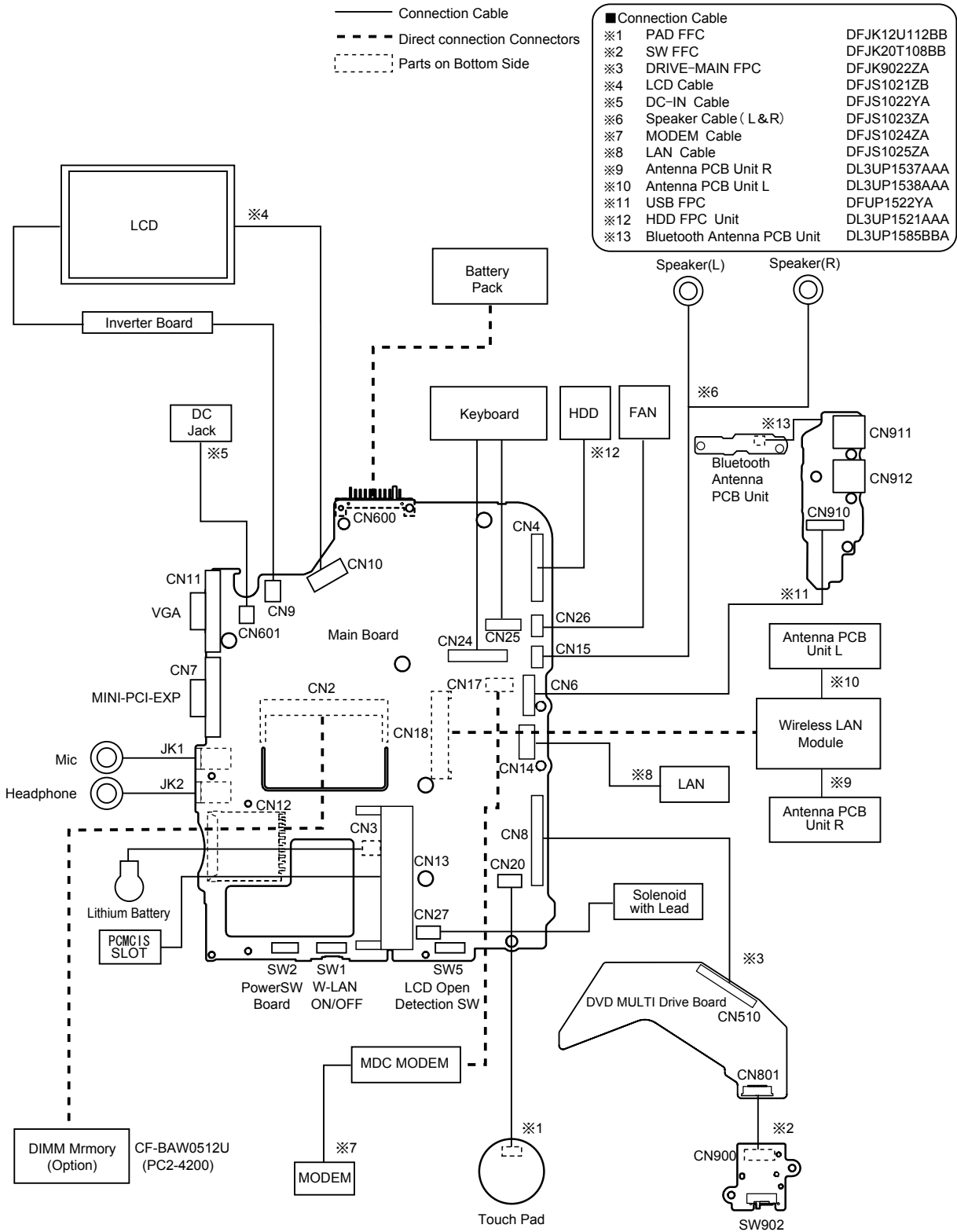

# 9 Disassembly instructions

## 9.1. Disassembly Flow Chart

### ● Main Unit

9.2.1.

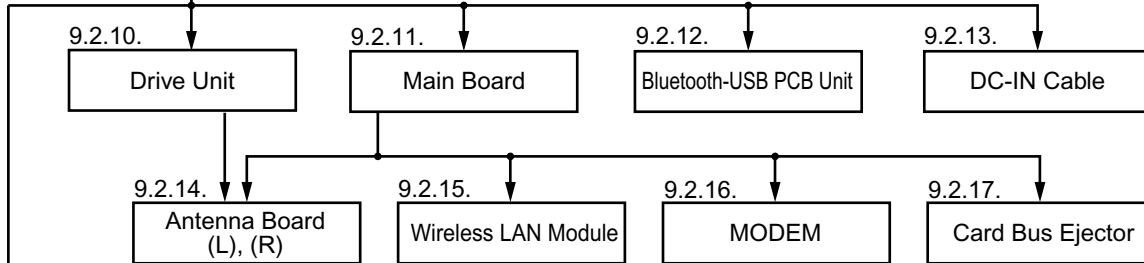
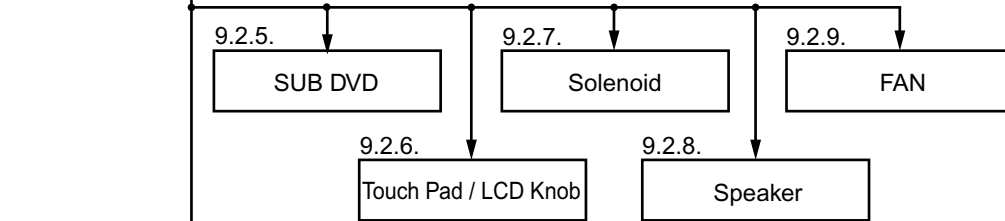
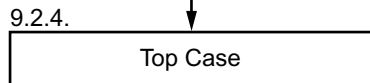
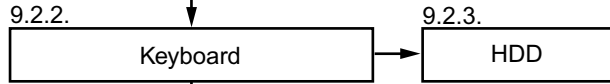
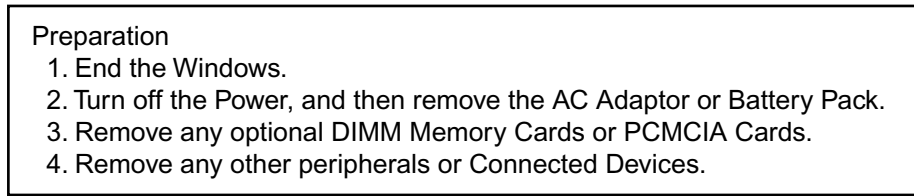

#### Main replaceable parts

### ● Display Unit

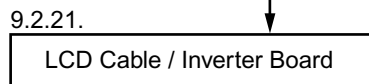
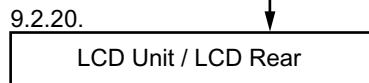
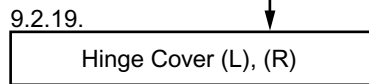
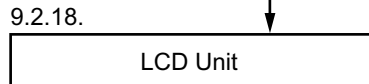

- |   |   |
|---|---|
| <p>9.2.1. -Battery Pack<br/>-DIMM Cover<br/>-Side Cover</p> <p>9.2.2. -HDD<br/>-HDD Cover</p> <p>9.2.3. -Keyboard<br/>-Keyboard Side Cover (L), (R)</p> <p>9.2.4. -Top Case<br/>-Disk Side Cover</p> <p>9.2.5. -SUB DVD<br/>-Disk Eject Knob</p> <p>9.2.6. -Touch Pad<br/>-LCD Knob<br/>-Pad Buttom<br/>-PAD FFC</p> <p>9.2.7. -Solenoid<br/>-Disk Cover Angle</p> <p>9.2.8. -Speaker</p> | <p>9.2.9. -FAN</p> <p>9.2.10. -Drive Unit</p> <p>9.2.11. -Main Board<br/>-Lithium Battery</p> <p>9.2.12. -Bluetooth-USB PCB Unit</p> <p>9.2.13. -DC-IN Cable</p> <p>9.2.14. -Antenna Board (L), (R)</p> <p>9.2.15. -Wireless LAN Module</p> <p>9.2.16. -MODEM</p> <p>9.2.17. -Card Bus Ejector</p> <p>9.2.18. -LCD Unit</p> <p>9.2.19. -Hinge Cover (L), (R)</p> <p>9.2.20. -LCD Rear<br/>-LCD Hook</p> <p>9.2.21. -Hinge (L), (R)<br/>-LCD Cable<br/>-Inverter Board</p> |
|---|---|

## 9.2. Disassembly Instructions

### 9.2.1. Preparation

**Attention:**

**Before disassembly, be sure to perform the following steps.**

1. End the Windows.
2. Turn off the power and then remove the AC adaptor.
3. Slide the hooks (A) and then remove the battery Pack.
4. Remove the screw (A) and then remove the DIMM cover.  
(Remove if the DIMM memory is equipped with)  
Screw (A) : XSB2+4FNL (N14)

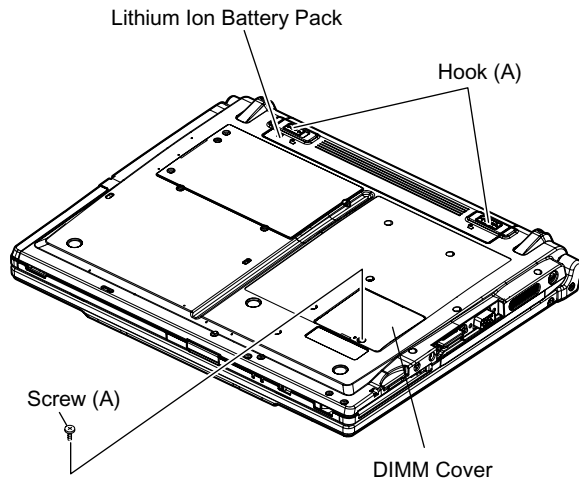

### 9.2.2. Removing the HDD

**Preparation : perform the section 9.2.1. first.**

1. Remove the 2 screws (B) and 1 screw (C).  
Screw (B) : DXQT2+D4FNL (N7)  
Screw (C) : DXQT2+E12FNL (N9)
2. Lift up the HDD unit and remove FFC connector and then remove the HDD unit.
3. HDD is taken out of the HDD case.

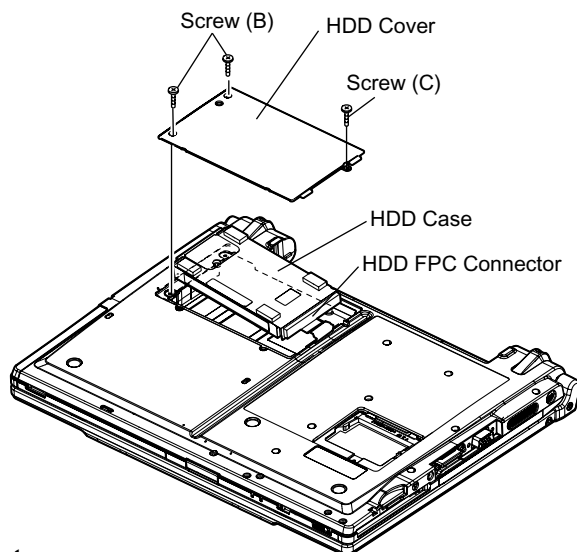

**Note :**

Please do not bend pins of the HDD connector, at the time of removing HDD and FFC connector.

### 9.2.3. Removing the Keyboard

**Preparation : perform the section 9.2.1. first.**

1. Remove the 7 screws (D).  
Screw (D) : DXQT2+E12FNL (N9)
2. Operate the LCD knob and open the LCD Unit to an angle of 90 degrees or more.  
The minus clock driver removes hook (B-1) in the intuition combination part so as not to damage from the W-LAN connector side space to the exterior, and then rotates to the keyboard side, and KB side cover is detached.
3. Remove the keyboard hook plates, and then remove the hook of back side of keyboard with screwdriver.

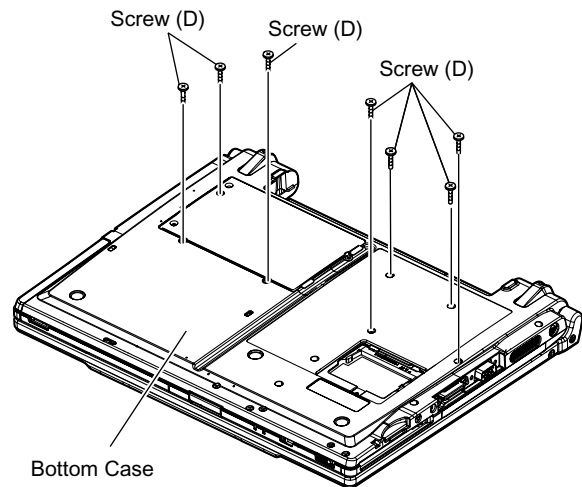

4. Operate the LCD knob and open the LCD unit to an angle of 90 degrees or more.  
The minus clock driver removes hook (B-1) in the hook position so as not to damage from the wireless LAN connector side space to the exterior, and then rotates to the keyboard side, and KB side cover is removed.

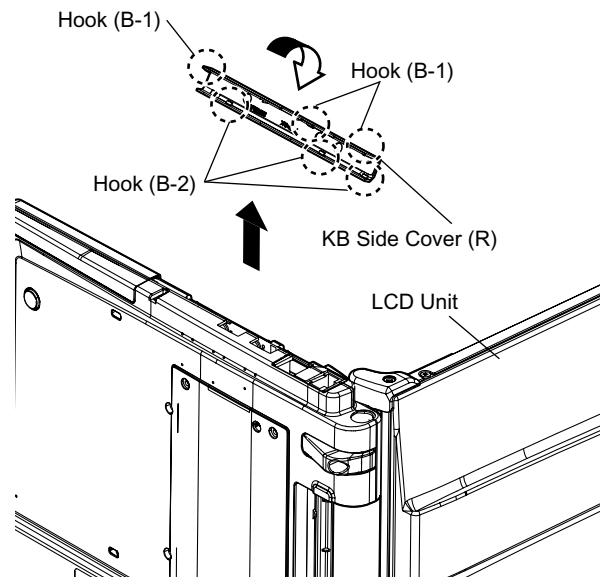

**Note :**

Be careful not to wrap the protection cloth etc. around minus clock driver's point, and be careful not to damage the exterior.

5. KB side cover (L) is adjusted to the upper part as well as KB side cover (R), the minus clock driver removes hook (C-1) in the hook position from the space with the bottom case, rotates to the keyboard side, and detaches.

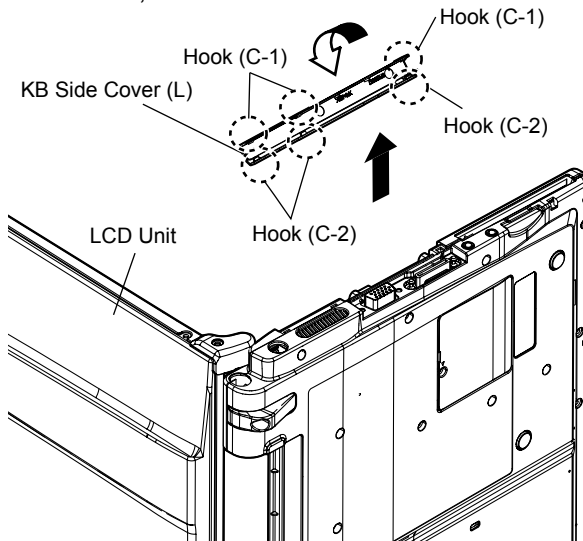

6. The both sides tape pasted to the keyboard bottom with the spatula is inserted in order of the arrow and then peel off. It is start-up from the LCD side and turns inside out on the top case. The KBD FPC WP sheet is peeled off, FFC (keyboard) is removed from connector (CN25) and (CN24), and then remove the keyboard.

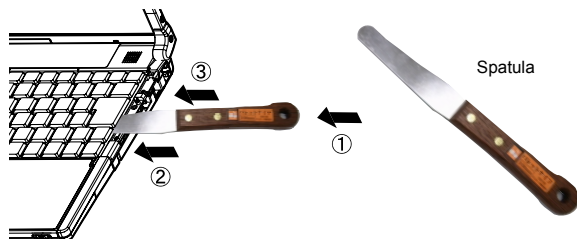

※ Do not damage the spatula ahead and move a top case in the direction of the arrow in ①-③ order.

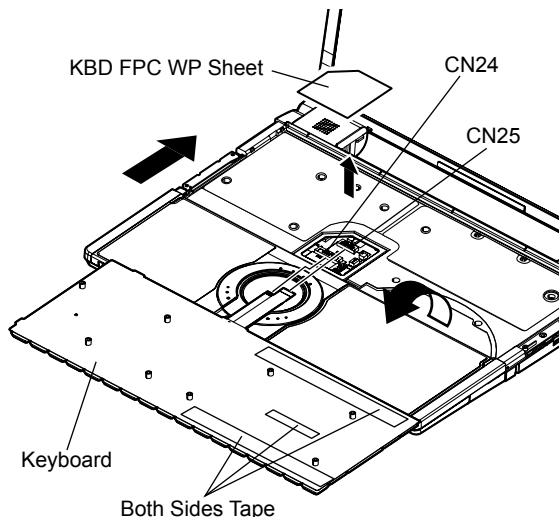

**Note:**

KBD-FPC sheet cannot be recycled. Please use new parts.

**9.2.4. Removing the Top Case**

**Preparation : perform the section 9.2.1., 9.2.3. first.**

1. Remove the 2 screws (E) and 2 foot rubber backs.  
Screw (E) : XTB26+10GFN (N12)
2. Remove the 5 screws (F).  
Screw (F) : DXHM0057ZA (N5)
3. Remove the 2 screws (G).  
Screw (G) : DXHM0049ZA (N3)
4. Remove the 1 screw (H) and 1 screw (I).  
Screw (H) : DXQT2+D4FNL (N7)  
Screw (I) : DXQT2+E10FNL (N8)

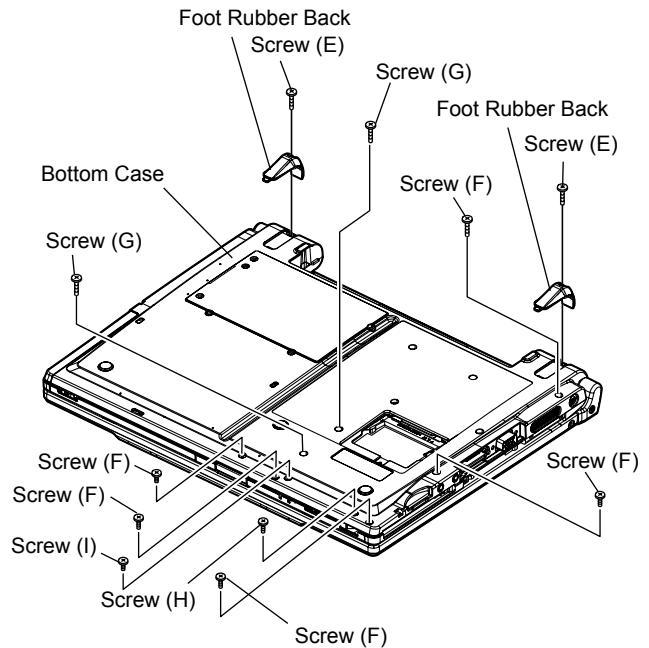

5. Operate the LCD knob and open the LCD Unit to an angle of 90 degrees or more.
6. The hook 2 places of the disk side cover are removed, and detaches forward while rotating in the direction of the upper surface.
7. The disk cover lock is mechanically released, and the disk cover is opened.

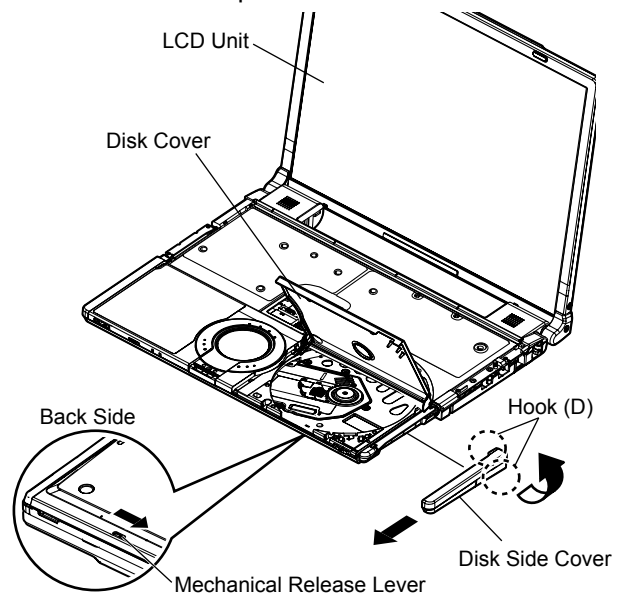

8. The disk cover shaft is removed and pulling out disk cover is removed from the disk cover.

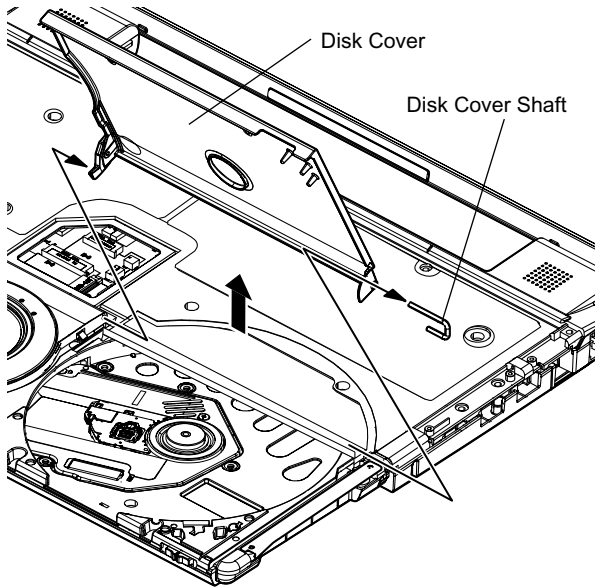

9. Remove the 8 screws (J), 3 screws (K), 3 screws (L), 4 screws (M) and 1 screw (N).  
 Screw (J) : DXQT2+E6FNL (N10)  
 Screw (K) : DRQT2+E8FKL (N2)  
 Screw (L) : DXQT2+E10FNL (N8)  
 Screw (M) : DXQT2+F3FNL (N16)  
 Screw (N) : DXHM0056ZA (N4)

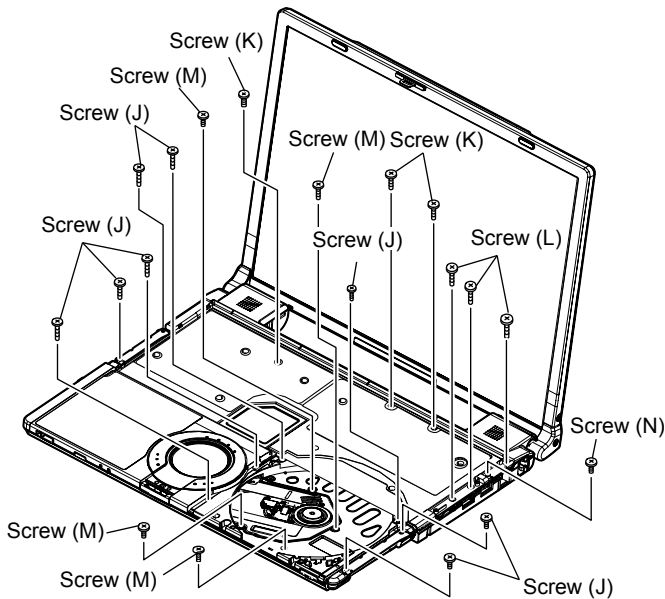

10. CN26 (FAN) and CN15 (SP) are removed. A top case is lifted and FFC (PAD), FFC (DRIVE) and CN27 (solenoid) are removed and then the top case is removed.

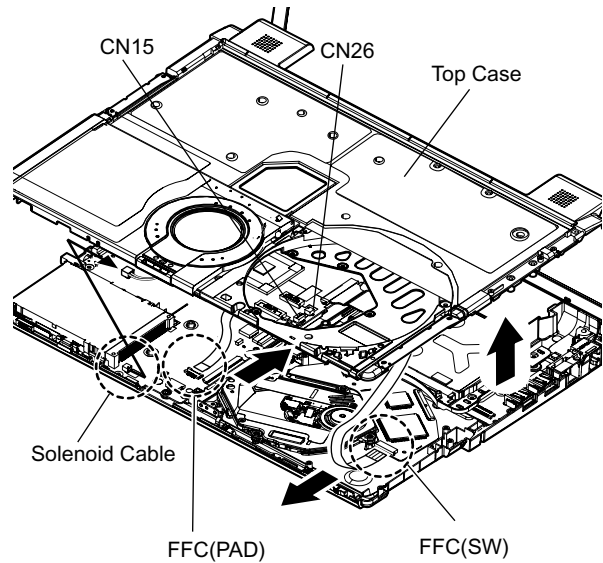

### 9.2.5. Removing the SUB DVD

**Preparation : perform the section 9.2.1., 9.2.3. and 9.2.4. first.**

1. Peel off the tape.
2. Remove the 2 screw (O) and then remove the SUB DVD.

Screw (O) : DXHM0056ZA (N4)

**Note:**

Note it that the disc eject knob comes off at the same time.

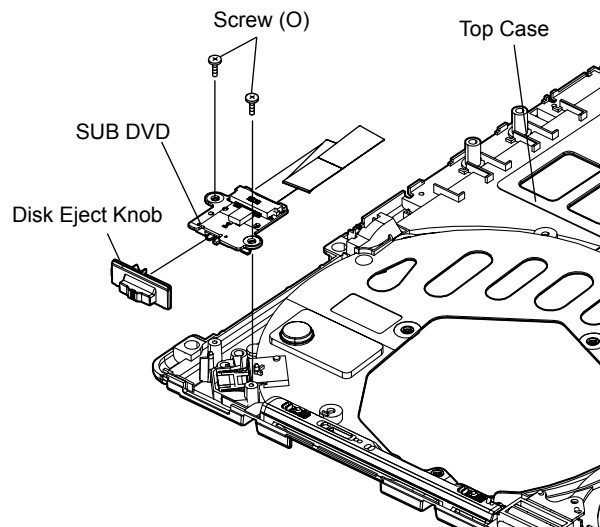

## 9.2.6. Removing the Touch Pad / LCD Knob

**Preparation :** perform the section 9.2.1., 9.2.3. and 9.2.4. first.

1. The pad top ring fixed to the pad cover by the both sides tape is removed, and remove the screw (P).  
Screw (P) : DXHM0057ZA (N5)

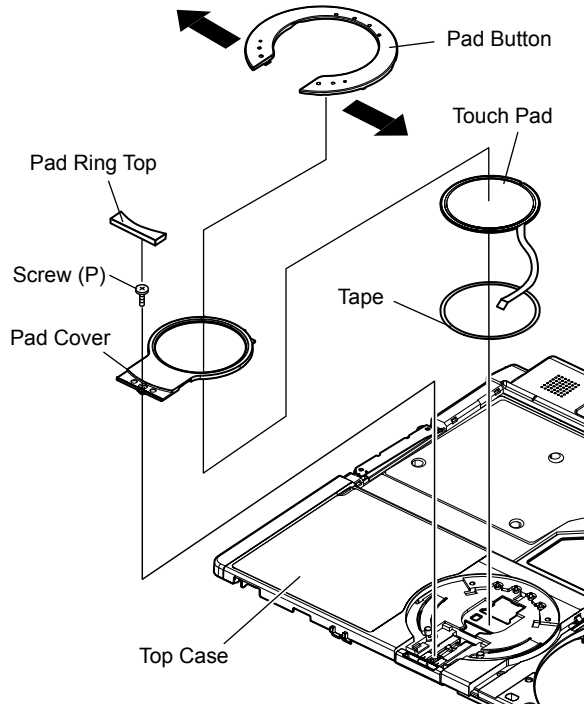

2. Peel off the pad sheet.

The LCD knob is lifted from a top case, and removing LCD knob is removed from the knob side in the LCD latch spring.

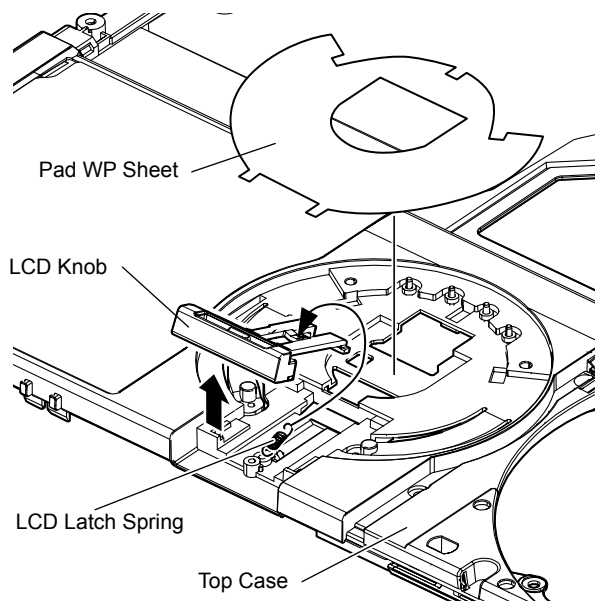

**Note:**

The pad sheet cannot be recycled. Please use new parts.

## 9.2.7. Removing the Solenoid / Disc Cover Lock

**Preparation :** perform the section 9.2.1., 9.2.3. and 9.2.4. first.

1. Remove the solenoid line hold sheet and cable fixed sheet.  
Solenoid line hold sheet : DFHR3D20ZA (K122)
2. Remove the 1 screw (Q) and the solenoid from the top case.  
Screw (Q) : DXHM0056ZA (N4)

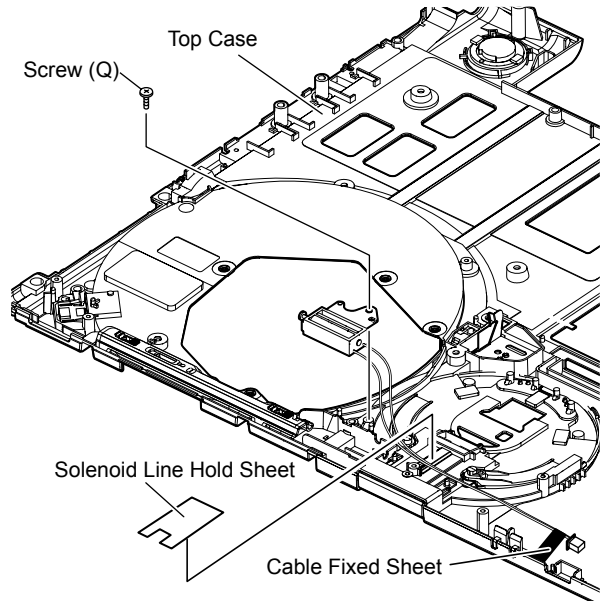

**Note:**

The each cable fixed tapes cannot be recycled. Please use new parts.

3. Remove the disc cover lock spring, and slide the disc cover lock and then remove.

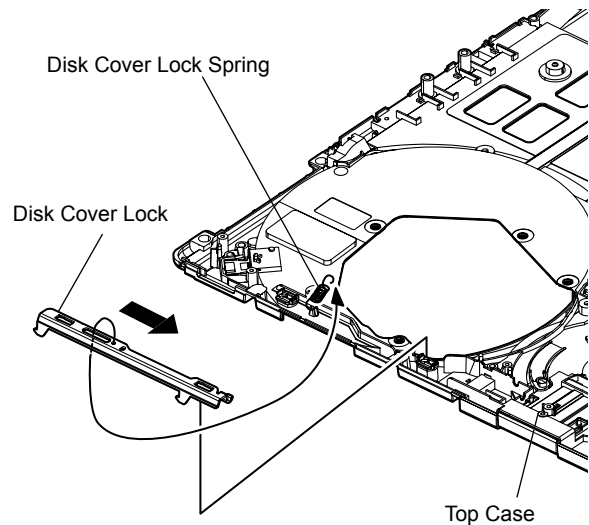

**Note:**

When expanding or transforming, the disk cover knob spring cannot be recycled.



## 9.2.8. Removing the Speaker (L), (R)

**Preparation :** perform the section 9.2.1., 9.2.3. and 9.2.4. first.

1. Peel off the 5 line hold sheet 1, the 4 brims of the DVD PWB sheet, and remove the speaker (L).  
Line hold sheet 1 : DFHR3D21YA (K123)  
DVD PWB sheet : DFMX1229ZA (K161)

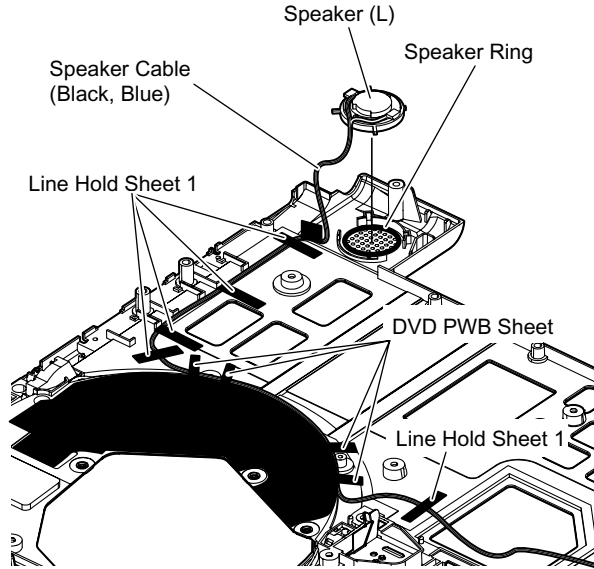

**Note:**

These sheet and speaker ring cannot be recycled. Please use new parts.

2. Peel off the 2 line hold sheet 1, line hold sheet 2 the 1 tape, and remove the Speaker (L).  
Line hold sheet 1 : DFHR3D21YA (K123)  
Line hold sheet 2 : DFHR3D22ZA (K124)

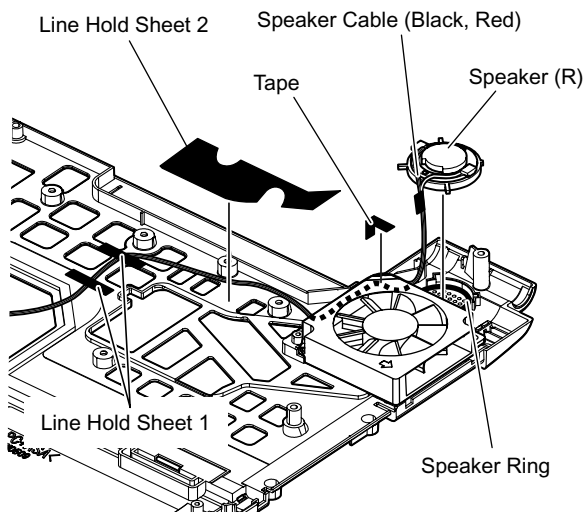

**Note:**

These sheets and speaker ring cannot be recycled. Please use new parts.

## 9.2.9. Removing the FAN

**Preparation :** perform the section 9.2.1., 9.2.3. and 9.2.4. first.

1. Remove the KB heat spreader and the heat spreader.
2. Remove the 1 screw (R)  
Screw (R) : DXHM0057ZA (N5)

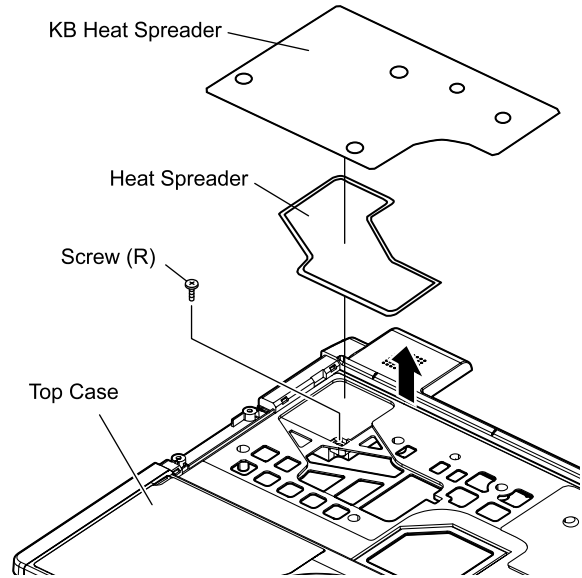

**Note:**

KB heat spreader and the heat spreader cannot be recycled. Please use new parts.

3. Remove the tape and line hold sheet 2 and then remove the FAN.  
Line hold sheet 1 : DFHR3D21YA (K123)  
Line hold sheet 2 : DFHR3D22ZA (K124)

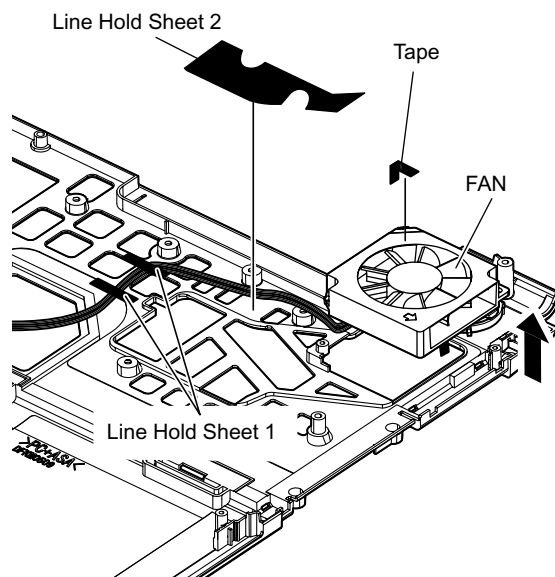

**Note:**

These sheets and tape cannot be recycled. Please use new parts.

## 9.2.10. Removing the Drive Unit

**Preparation :** perform the section 9.2.1., 9.2.3. and 9.2.4. first.

1. Peel off the tape from the connector.
2. DVD FFC is removed from connector (CN501), and the drive unit is lifted from the bottom case, and the gasket is peeled off and then remove the drive unit.

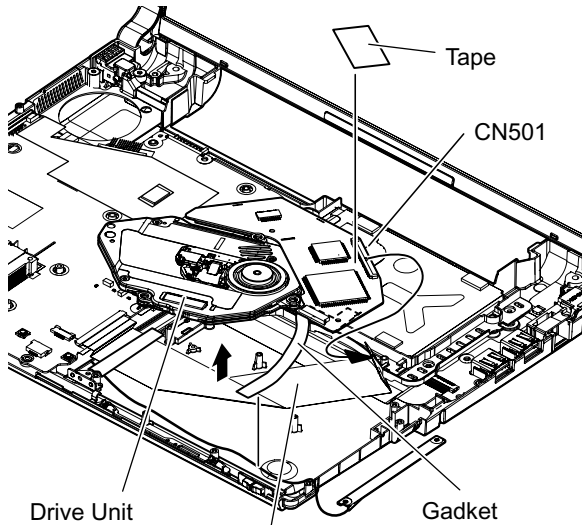

**Note:**

DRIVE-MAIN FFC

-When you exchange DRIVE-MAIN FFC, mark the bottom case, and match new FFC to marking of the bottom case, bend, and build the bend externals of FFC before peeling off FFC from the bottom case.

-Tape and gasket cannot be recycled. Please use new parts.

## 9.2.11. Removing the Main Board

**Preparation :** perform the section 9.2.1., 9.2.3. and 9.2.4. first.

1. Remove the 2 screws (S), 2 screws (T) and 1 screw (U).  
Screw (S) : K1YE500022 (N15)  
Screw (T) : DFHE5035ZB (N1)  
Screw (U) : DXQT2+E6FNL (N10)
2. Peel off the 6 tapes, main PWB sheet and line hold sheet 3.

Main PWB sheet : DFMX1228ZA (K64)

Line hold sheet 3 : DFHR3D59YA (K47)

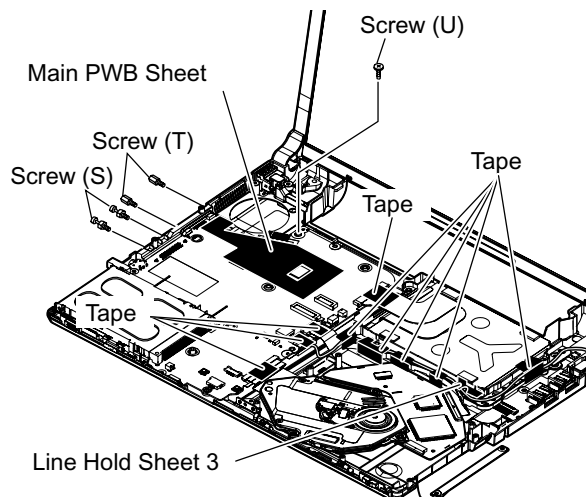

3. Disconnect the LCD connector (CN9) (CN10), DC-IN connector (CN601) and FFC (CN4) (CN6) (CN18) (CN8).

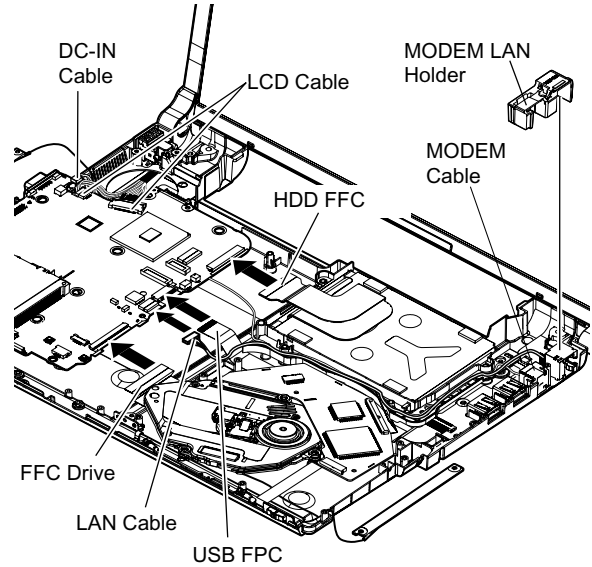

4. Turn inside out the main board. Remove the antenna cable (L), (R) from the wireless LAN module, and then remove the main board.
5. Remove the connector from CN3 and then remove the coin battery.

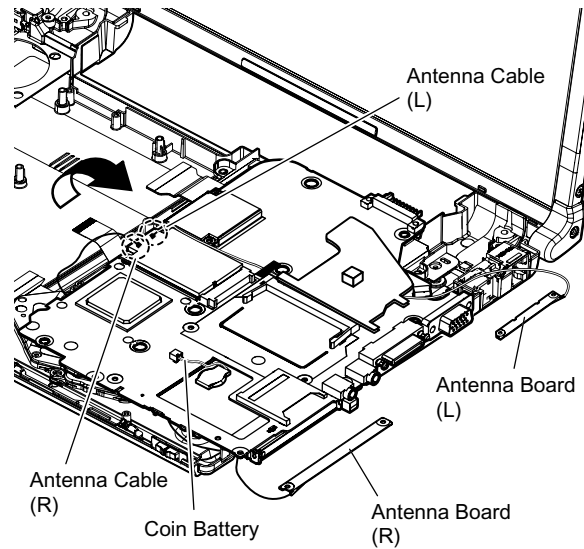

### 9.2.12. Removing the Bluetooth-USB PCB Unit (with BT) / Bluetooth Antenna PCB Unit

Preparation : perform the section 9.2.1., 9.2.3. and 9.2.4. first.

1. Remove the screw (V).  
Screw (V) : DXQT2+D25FNL (N6)
2. Remove the USB FPC from the tape and CN910, and then remove the bluetooth-USB PCB unit.

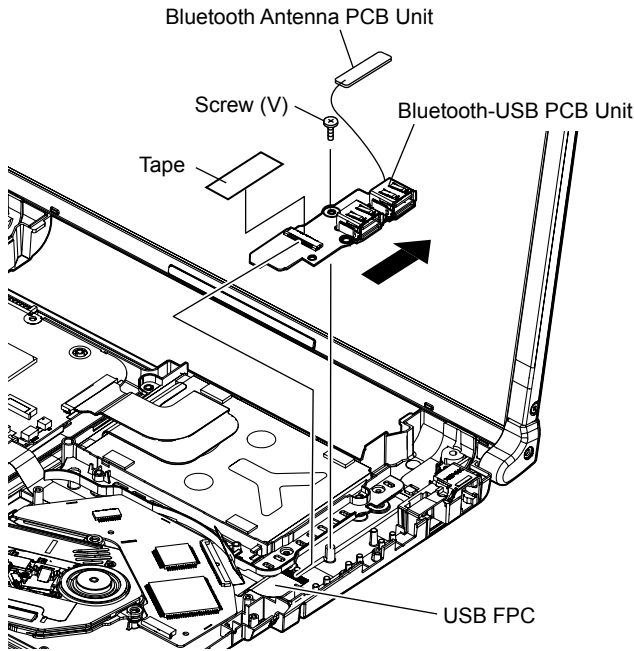

### 9.2.13 . Removing the DC-IN Cable

Preparation : perform the section 9.2.1., 9.2.3. and 9.2.4. first.

1. Remove the 1 screw (W) .  
Screw (W) : DXQT2+E6FNL (N10)
2. DC-IN jack plate, DC MDM cover, DC-IN cable connector (CN601), and FAN sheet are peeled off, and then remove the DC-IN cable.

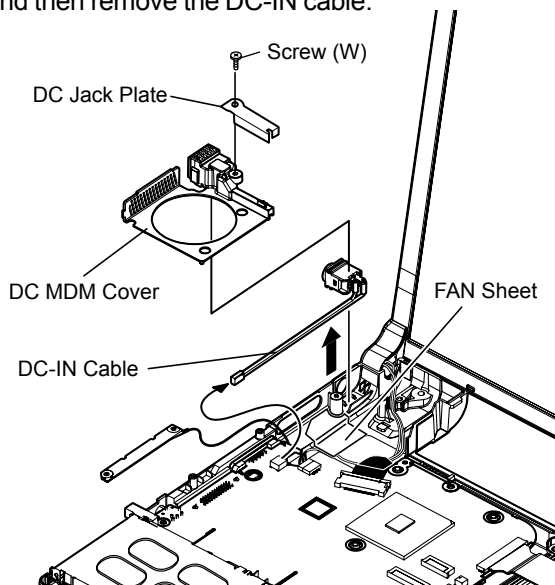

**Note:**

FAN sheet cannot be recycled. Please use new parts.

### 9.2.14. Removing the Antenna Board Unit (L), (R)

Preparation : perform the section 9.2.1., 9.2.3., 9.2.4., 9.2.10. and 9.2.11. first.

1. Peei off the line hold sheet and drive EMI sheet and then remove the antenna board (R).  
Line hold sheet : DFHR3D80ZA (K52)  
Drive EMI sheet : DFHE1003ZA (K38)

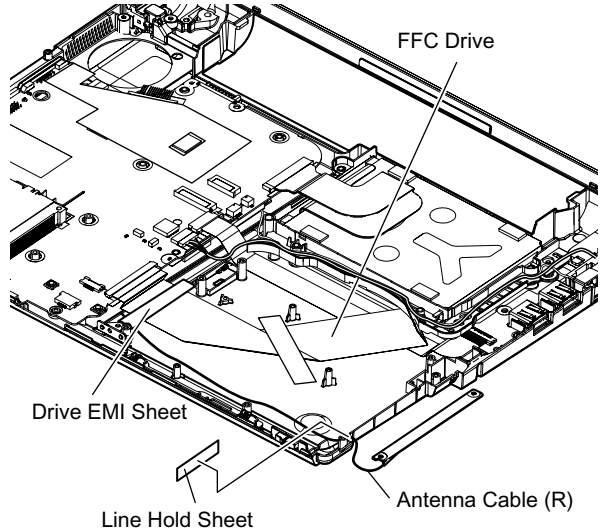

**Note:**

These sheet cannot be recycled. Please use new parts.

2. Line hold sheet 1 and heat spreader bottom are peeled off from main Board's wireless LAN side, and takes the antenna cable (L) out from the ditch and then remove the antenna board (L).  
Line hold sheet 1 : DFHR3D21ZB (K43)  
Heat spreader bottom : DFMY3222ZA (K69)

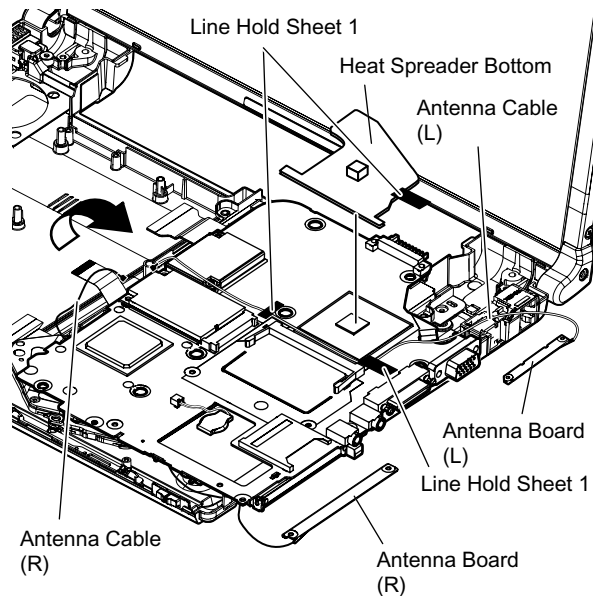

**Note:**

Line hold sheet 1 and heat spreader bottom cannot be recycled. Please use new parts.

### 9.2.15. Removing the Wireless LAN Module

Preparation : perform the section 9.2.1., 9.2.3., 9.2.4. and 9.2.11. first.

1. Remove the 2 screws (X).  
Screw (X) : DXQT2+D25FNL (N6)
2. Wireless LAN module is floated in the connector fulcrum and removed.

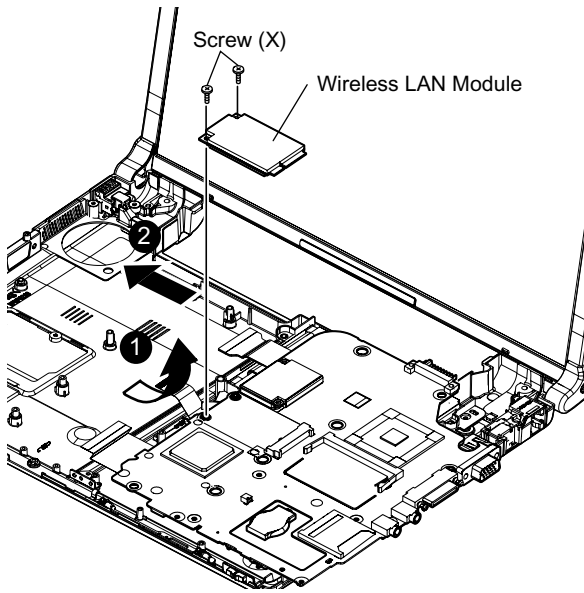

### 9.2.17. Removing the Card Bus Ejector

Preparation : perform the section 9.2.1., 9.2.3., 9.2.4. and 9.2.11. first.

1. Remove the 1 screw (Z) from connection side of wireless LAN.  
Screw (Z) : DXQT2+D25FNL (N6)

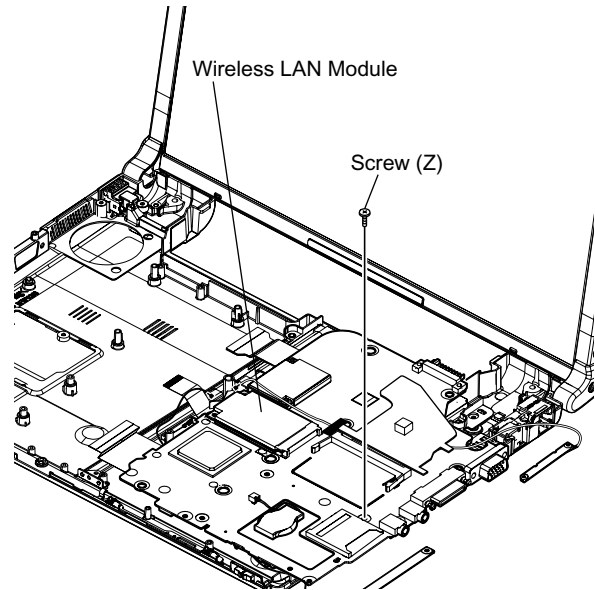

### 9.2.16. Removing the MODEM

Preparation : perform the section 9.2.1., 9.2.3., 9.2.4. and 9.2.11. first.

1. Remove the 2 screws (Y).  
Screw (Y) : DXQT2+D25FNL (N6)
2. MODEM will be removed from connector (CN17) to the vertical direction.

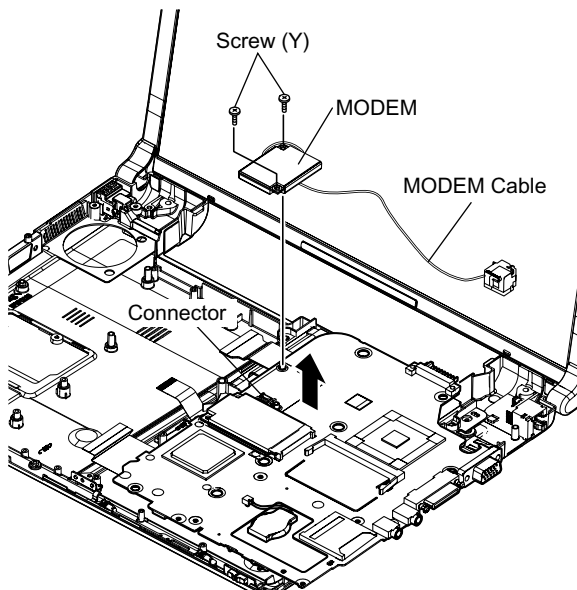

2. Return it on the revers to the card bus ejector side.
3. The minus small driver is inserted in connector (CN13) and the card bus ejector intuition combination parts, 2 places of hooks (E). And then remove the card bus ejector.

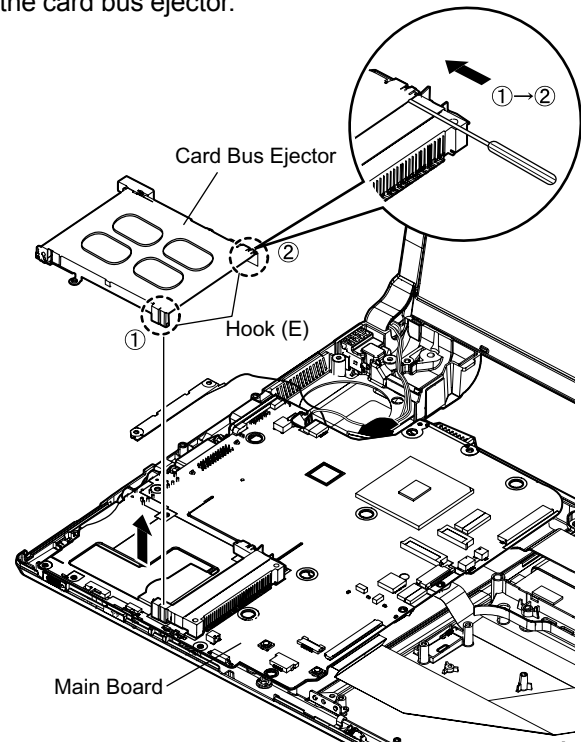

#### Note :

Be careful not to transform the card bus ejector when you remove the hook.

## 9.2.18. Removing the LCD Unit

**Preparation :** perform the section 9.2.1., 9.2.3. and 9.2.4. first.

1. Remove the 1 screw (a).  
Screw (a) : DXQT2+E6FNL (N10)
2. Remove the DC-IN jack plate, DC MDM cover and FAN sheet.  
FAN sheet : DFMY0428ZA (K65)
3. Peel off the main PWB sheet and remove the connector (CN9), (CN10) of the main board.  
Main PWB sheet : DFMX1228ZA (K64)

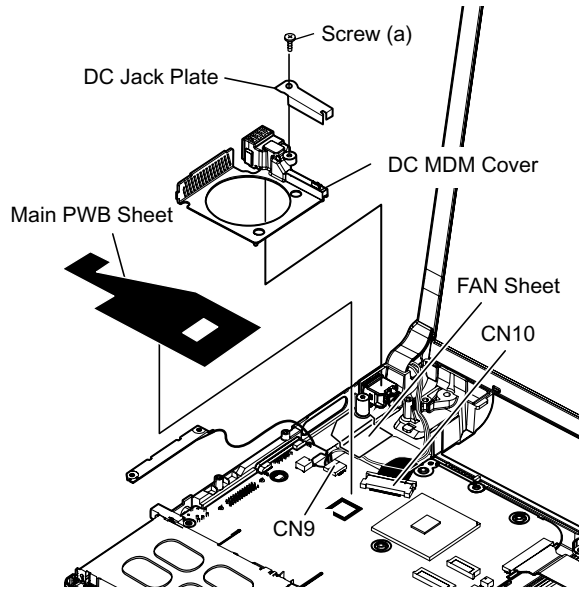

**Note:**

These sheet cannot be recycled. Please use new parts.

4. Remove the 2 screws (b).  
Screw (b) : DXYN26+J6FNM (N11)
5. Peel off the EMI sheet 3 and then remove the LCD unit.

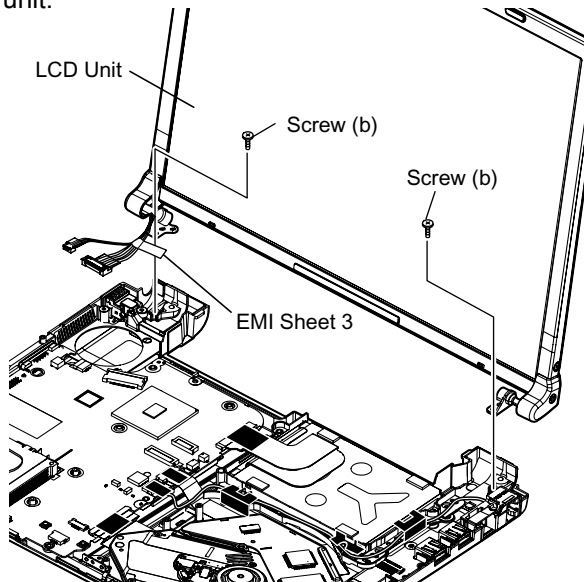

## 9.2.19. Removing the Hinge Cover (L), (R)

**Preparation :** perform the section 9.2.1., 9.2.3., 9.2.4. and 9.2.18. first.

1. Remove the 2 screws (c) and then remove the hinge Cover (L), (R).  
Screw (c) : DRHM0076ZA (N17)

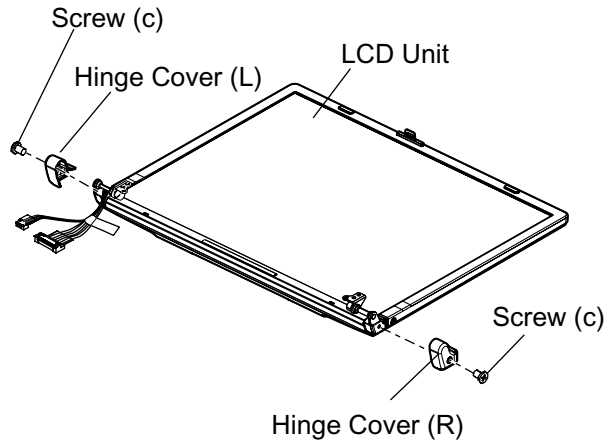

**Note:**

Screw (c) cannot be recycled. Please use new parts.

## 9.2.20. Removing the LCD Unit and the LCD Rear

**Preparation :** perform the section 9.2.1., 9.2.3., 9.2.4., 9.2.18. and 9.2.19. first.

1. Remove the 2 screws (d).  
Screw (d) : DRHM0076ZA (N17)

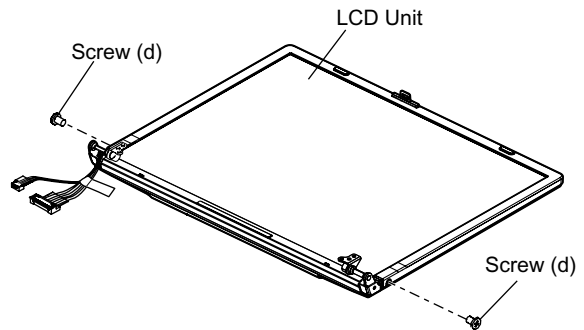

**Note:**

Screw (d) cannot be recycled. Please use new parts.

2. The intuition combination part of LCD rear case (21 places) is separated with LCD front case.

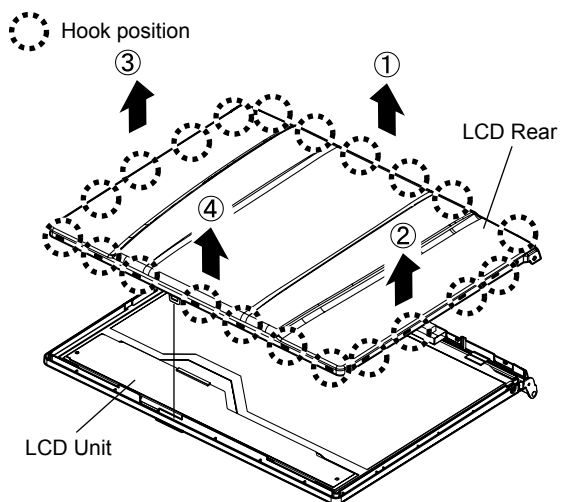

**Note:**

-When each hook is removed, it becomes easy to detach if the driver who wraps protection cloth etc. is inserted with LCD Front Case between LCD rear covers, and the side is repeated.  
 -Do noting that externals are not damaged.

3. Remove the 1 screw (e) from LCD rear and then remove the LCD hook.

Screw (e) : DXQT2+D25FNL (N6)

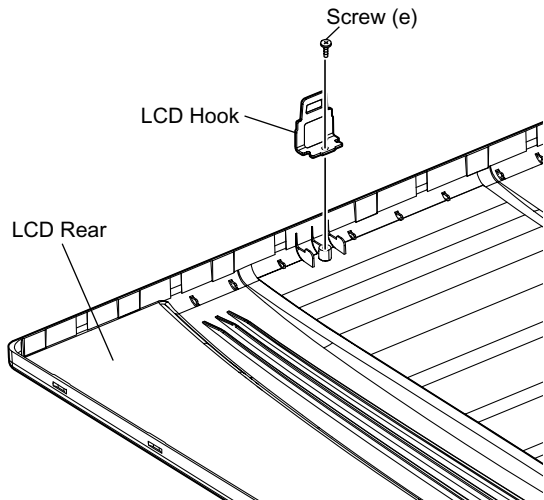

### 9.2.21. Removing the LCD Cable / Inverter Board

**Preparation :** perform the section 9.2.1., 9.2.3., 9.2.4., 9.2.18. and 9.2.20. first.

1. Peel of the damper, conductive cloth, inverter tape and the tape.

Inverter tape : DFHR3E07ZA (K18)

2. Remove the hinge (L), (R).

3. LCD Ccable is removed from LCD unit board (CN101), and connector (CN1) is removed from inverter board.

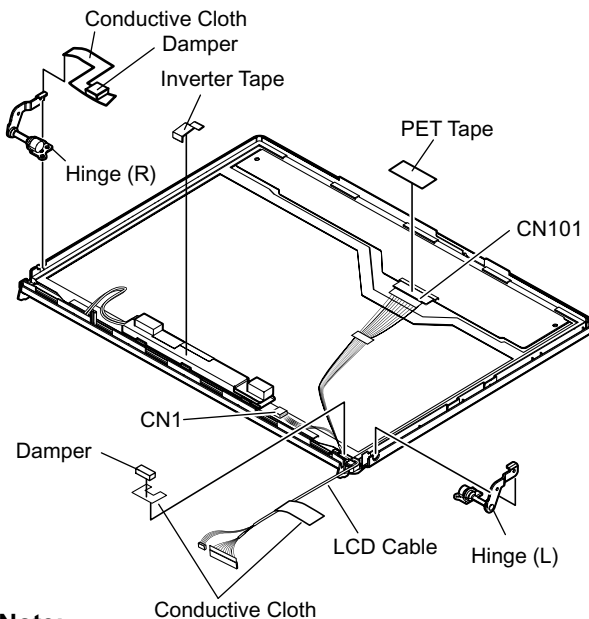

**Note:**

Conductive cloth and tapes cannot be recycled. Please use new parts.

4. Inverter case is peeled off and Inverter fixed with a both sided tape is taken out.

5. Peel off the tape from inverter.

6. Remove the connector (CN2) and then remove the inverter.

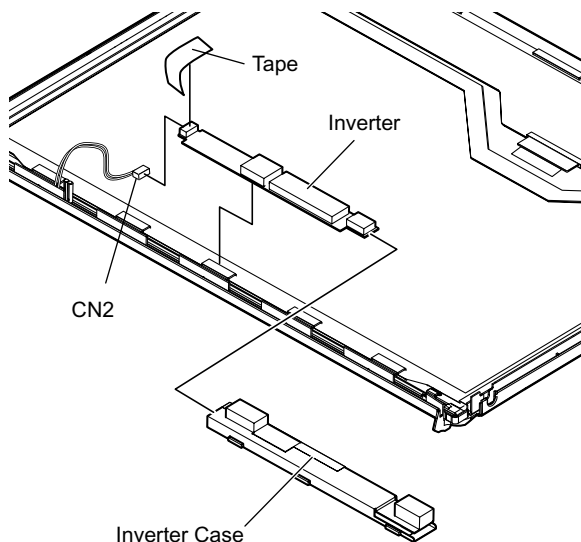

**Note:**

Tape and inverter case cannot be recycled. Please use new parts.

### 9.3. Reassembly instructions

#### 9.3.1. Attention when CF-Y5L series is repaired

- Please execute writing BIOS ID when you exchange the main board.
- Parts (sheet and rubber) etc.related various the conductive cloth and heat spreader cannot be recycled.Use new parts.

#### 9.3.2. Assembly knowhow of the LCD

##### 9.3.2.1. Assembly of the LCD Front

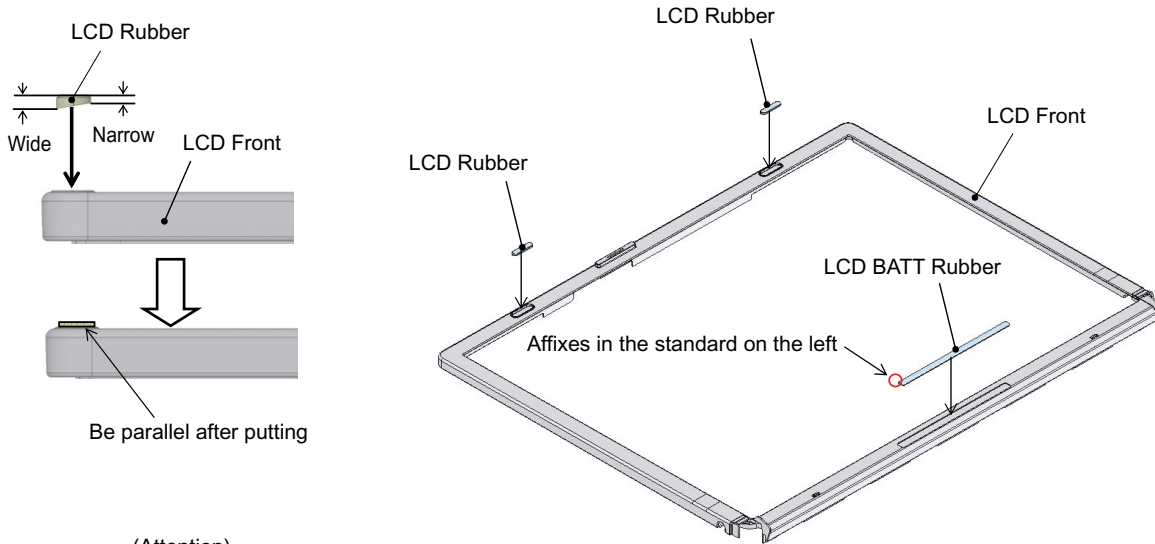

(Attention)

-The LCD Front is installed in the receiving stand, and works.

**Safety Work**

-The LCD rubber and LCD BATT Rubber does not out of the concave part, moreover, not run aground.

-It is noted that the finger does not touch the paste side when the LCD Rubber and LCD BATT Rubber are affixed.

##### 9.3.2.2. Putting LCD Side Cushion / LCD Tape 1

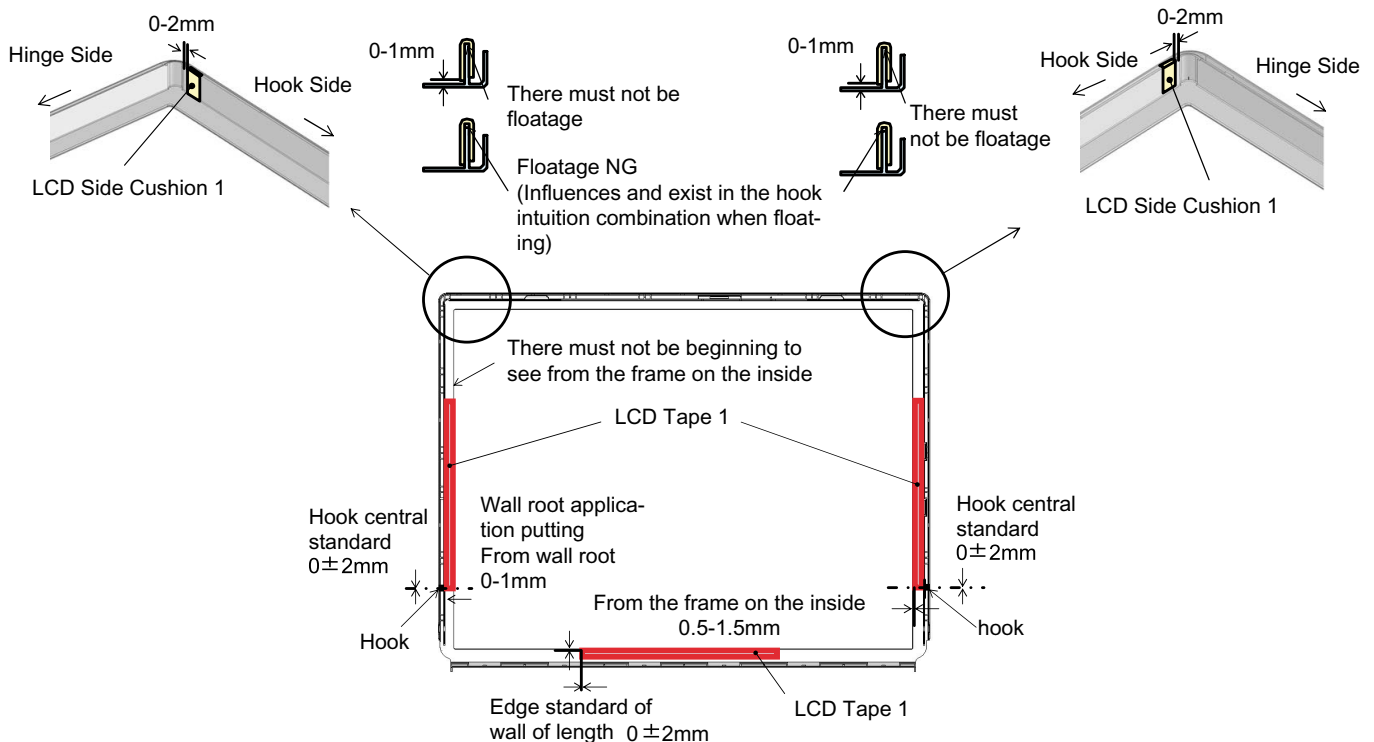

### 9.3.2.3. Putting LCD Side Rubber / LCD Side Damper

(LCD handling attention)

-Do not take out the vicinity of the center of the lamp side having when you take out LCD of the packing box.

(Because there is a possibility that the transformation of the lamp reflector etc. occur)

-Take out right and left both ends of the lamp side having when you take out LCD.

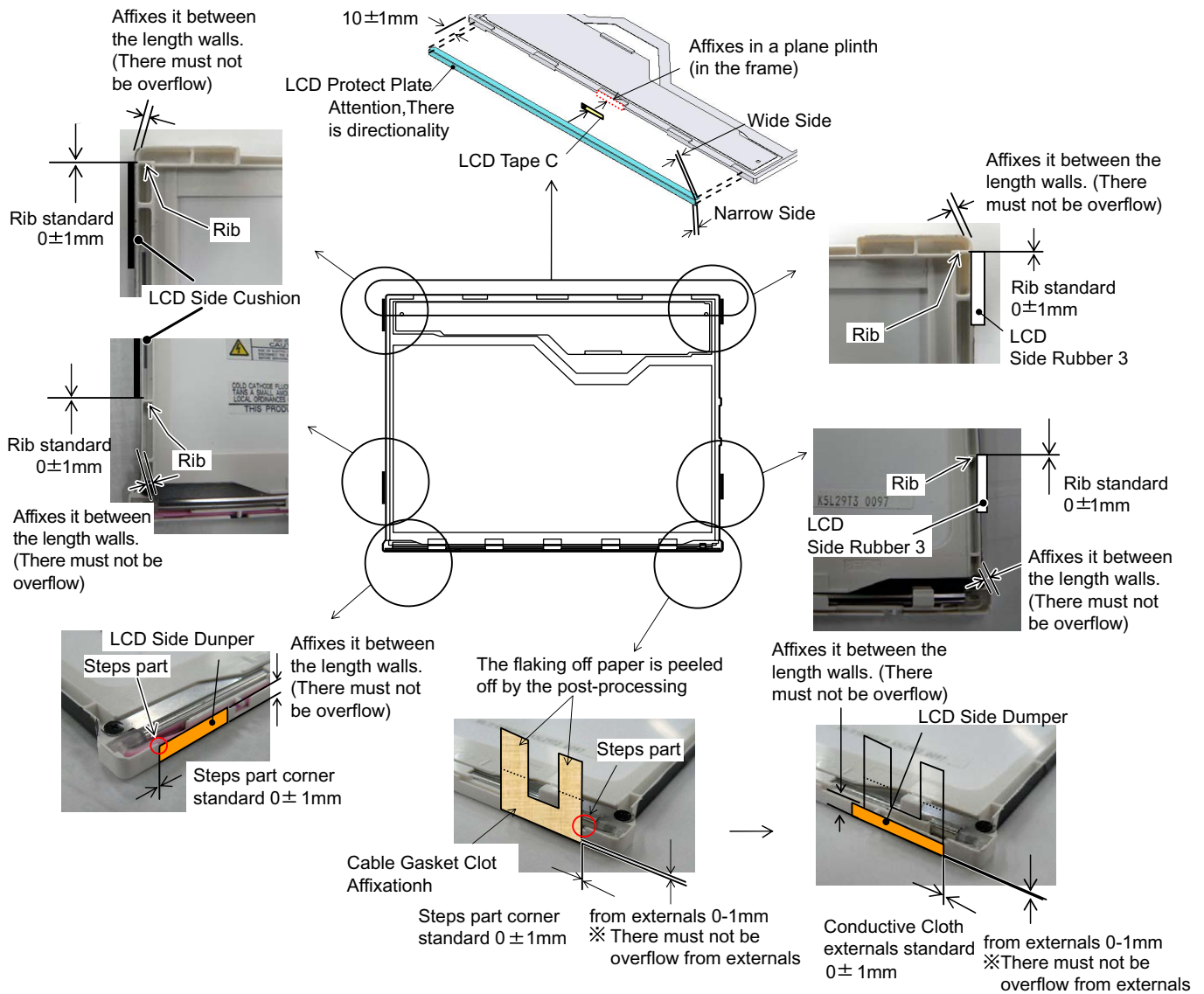



### 9.3.2.4. Putting LCD Magnet

(Attention)

-The LCD Front is installed in the receiving stand, and works.

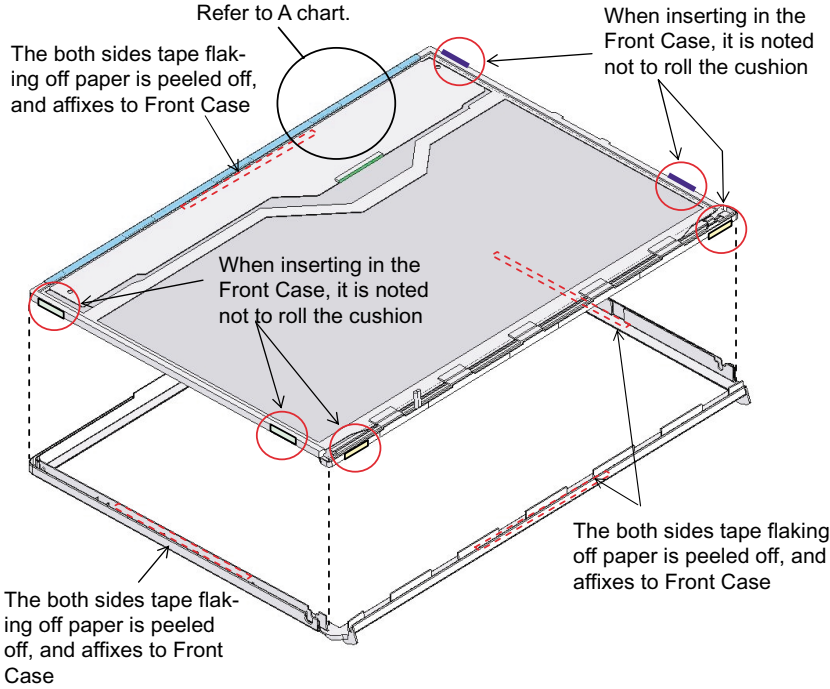

Pressurize it from the Front Case side (painting side) when you pressurize a two sided tape

**A**

The LCD Magnet is affixed to the dotted line part. (Affix on the plate side)

LCD Magnet

**Safety Work**

Fit to inside surface.

Paste side

Affixes between ribs

Use the treatment device when you affix the LCD magnet

Division attention for XGA (There is marking)

### 9.3.2.5. Putting LCD Cushion / Assembly of the Inverter

(Attention)

-The LCD Front is installed in the receiving stand, and works.

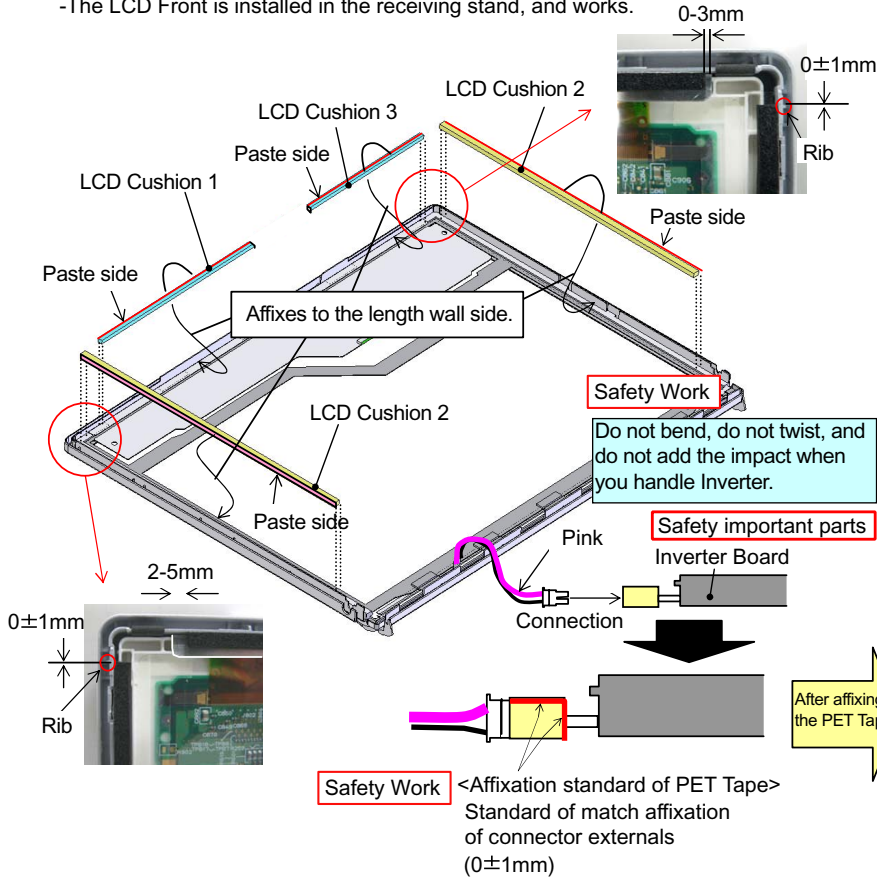

LCD Cushions

Paste side

There is no space.

LCD

<Affixation OK figure>

LCD Cushions

Paste side

There is a space.

LCD

<Affixation NG figure>

**Safety Work** Affixes in a connector externals putting together. (wrapping)

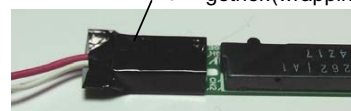

**Safety Work** <Affixation standard of PET Tape>  
Standard of match affixation of connector externals (0±1mm)

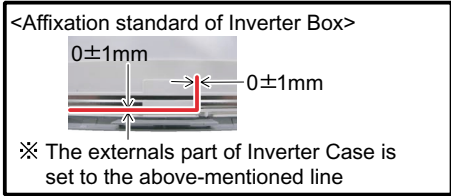
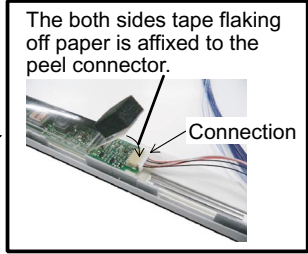
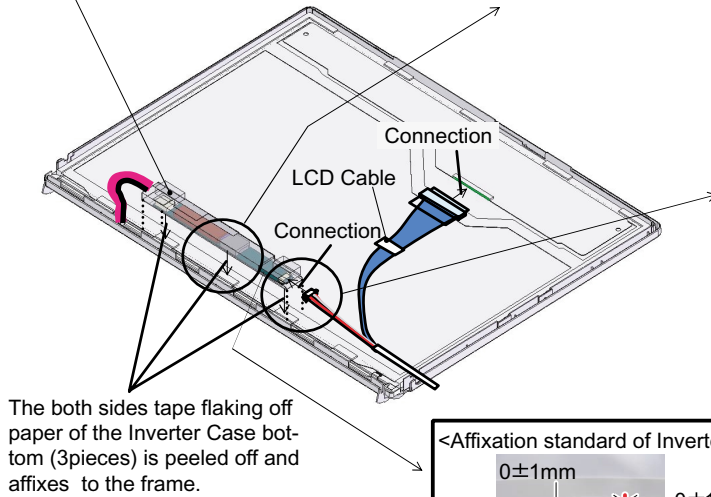
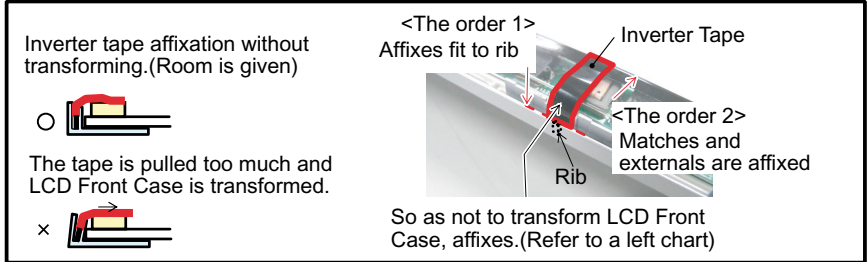
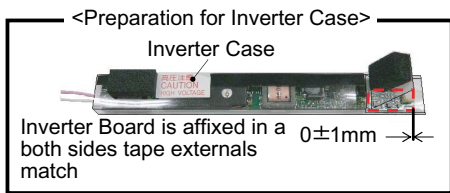

9.3.2.6. Putting Tape for LCD Cable

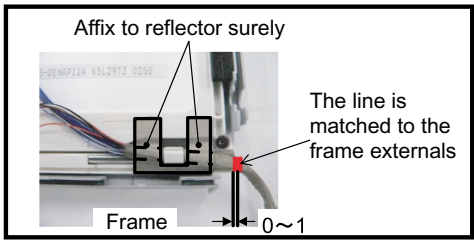
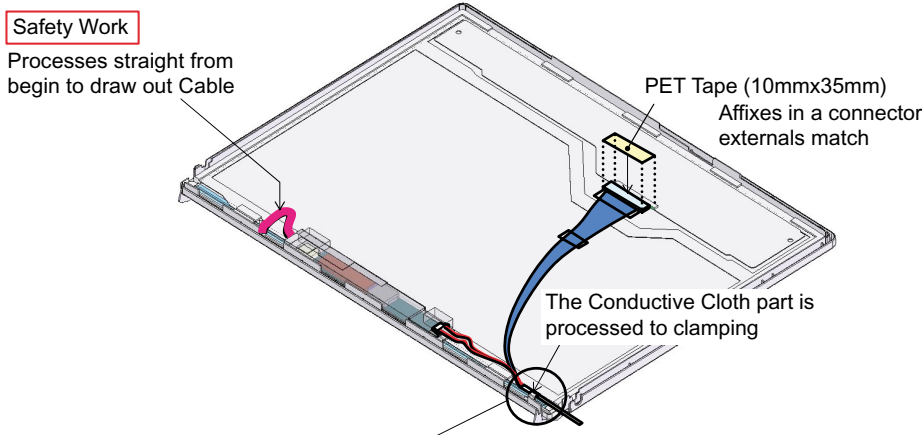

### 9.3.2.7. Assembly of the Hinge (L), (R)

(Attention)

-The LCD Front is installed in the receiving stand, and works.

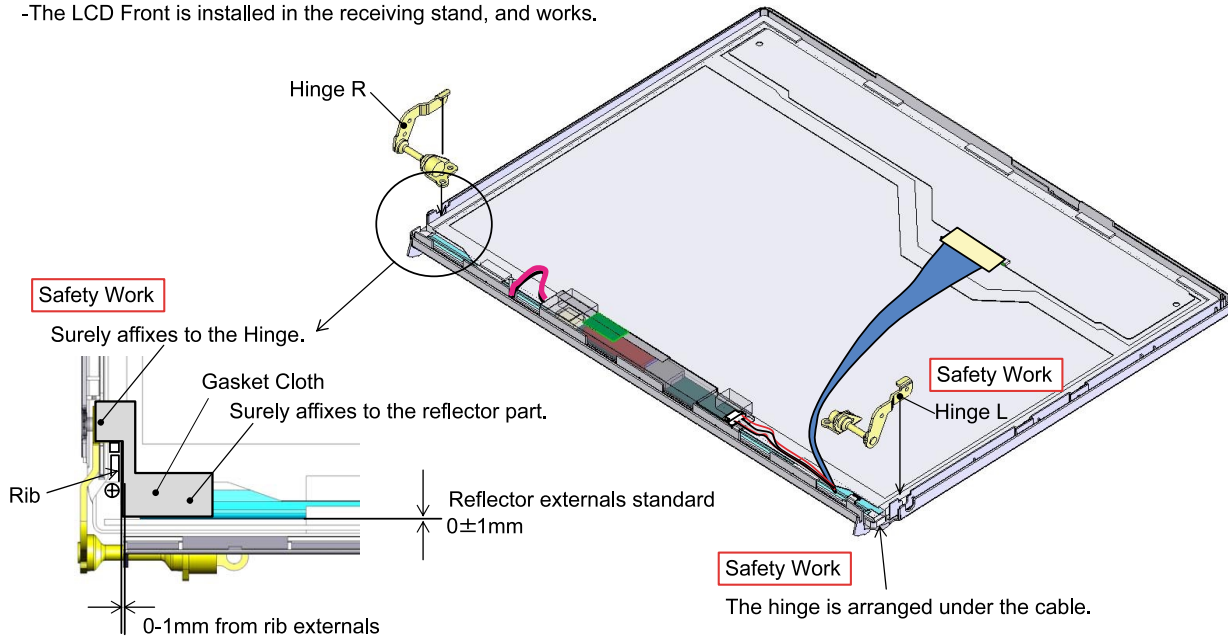

### 9.3.2.8. Putting LCD Rear Cushion / LCD Side Cushion

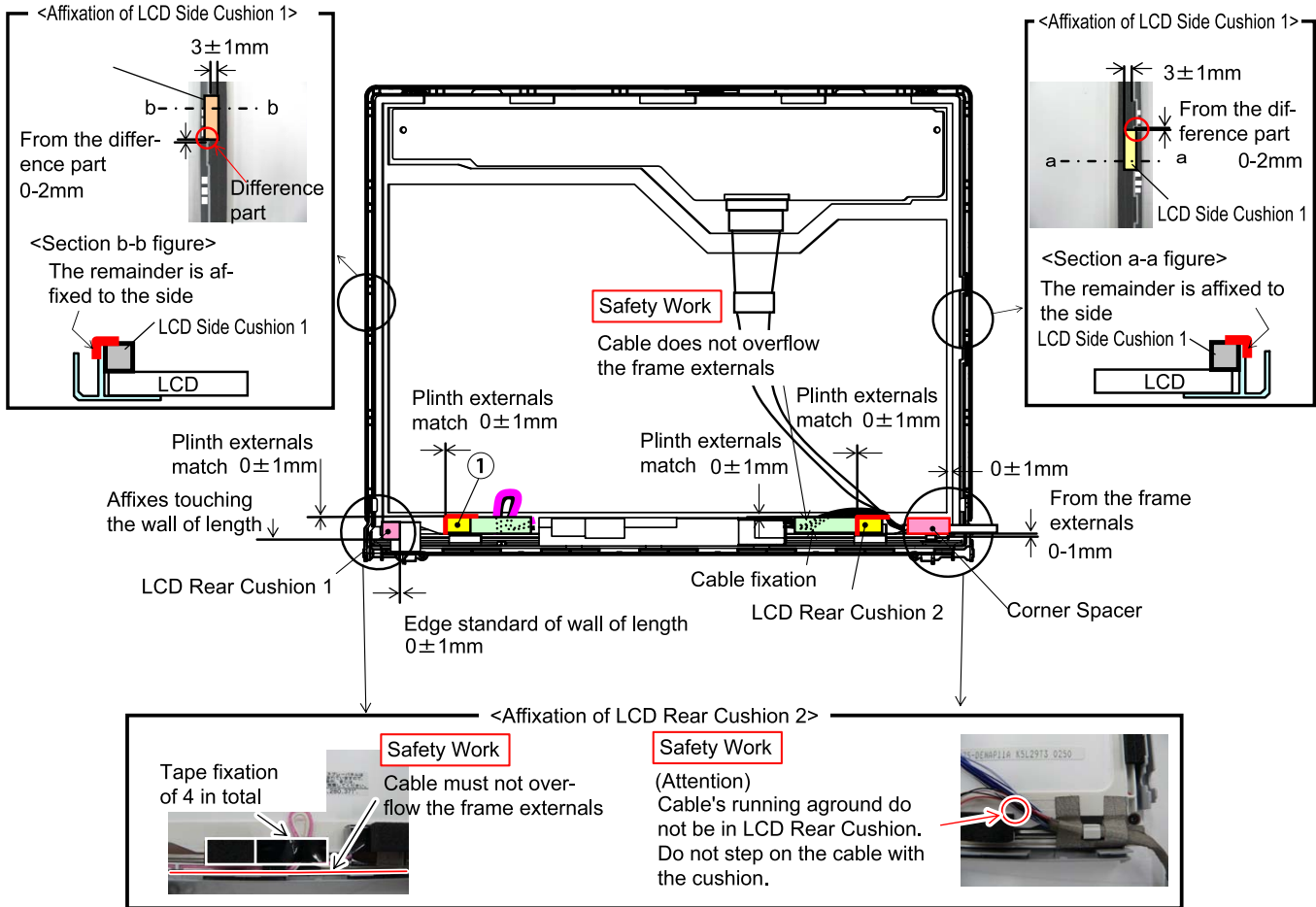

### 9.3.2.9. Assembly of the LCD Rear / LCD Front

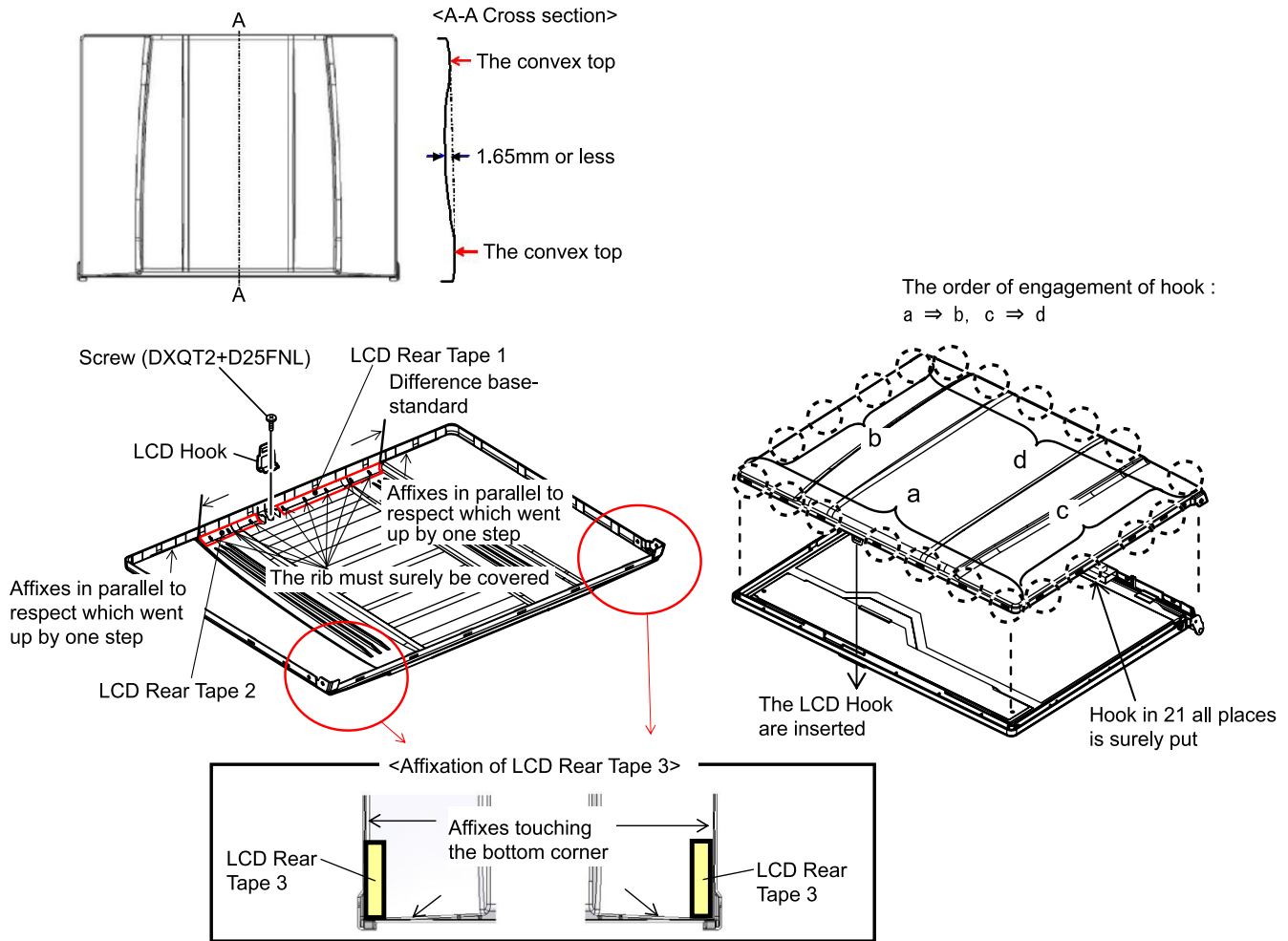

### 9.3.2.10. Assembly of the Hinge Cover (L), (R)

<Attention>

The tightening order : a ⇒ b

- Conclude after confirming there is a machine screw hole.
- The thing that the machine screw is not concluded imperfect is confirmed. (Generated by DVT a diagonal conclusion)

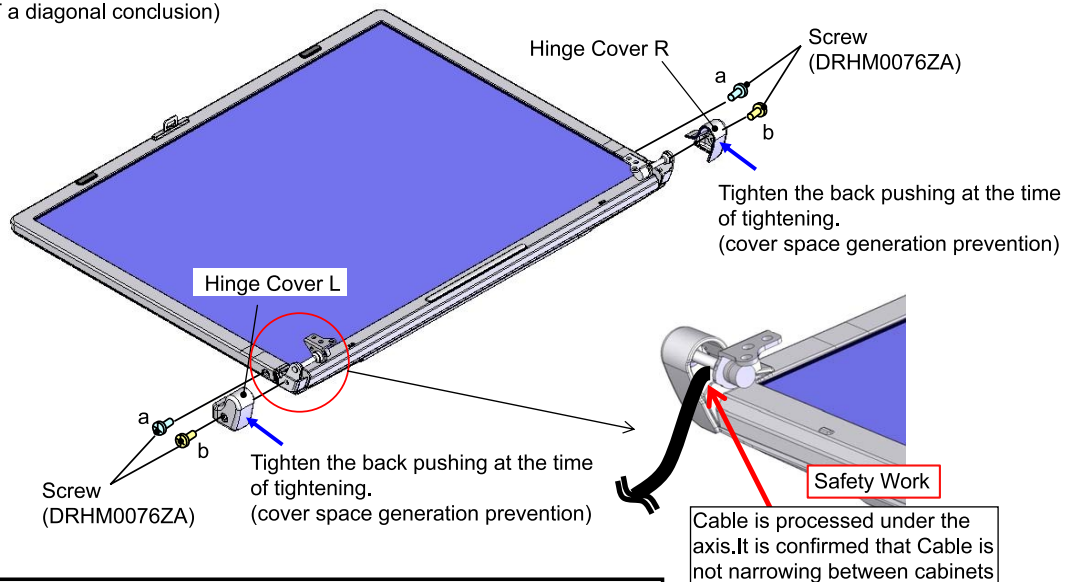

<Attention>

- The Screw (DRHM0076ZA) cannot use the fixed lock medicine repeatedly for use.
- Exchange for the new article when tightening again.



### 9.3.3. Assembly knowhow of the Main Board

#### 9.3.3.1. Putting Line Hold Sheet / Antenna Sheet / BT PWB Cushion

(Attention)

-Execute after setting board in the receiving treatment device when working.

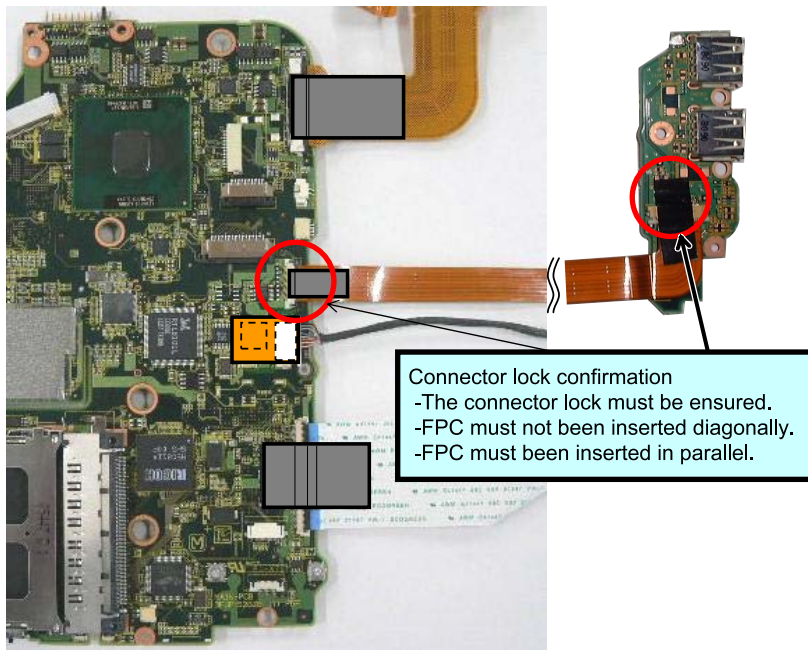
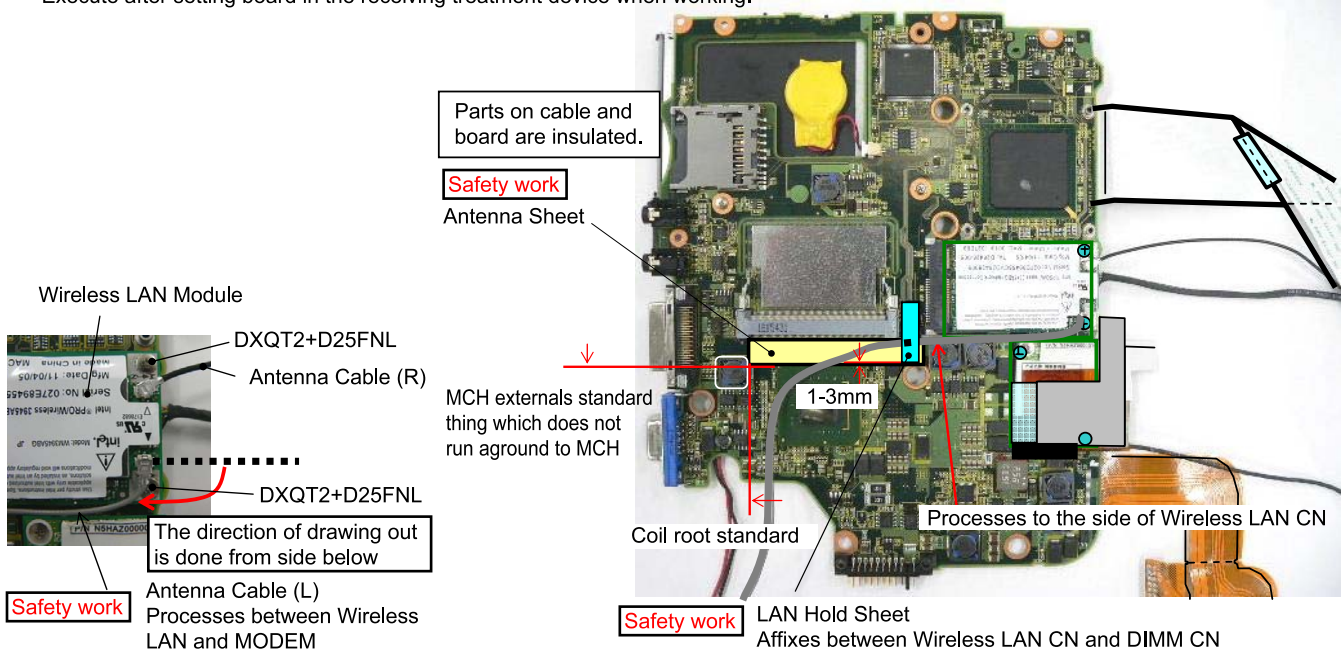

BT ANT PWB

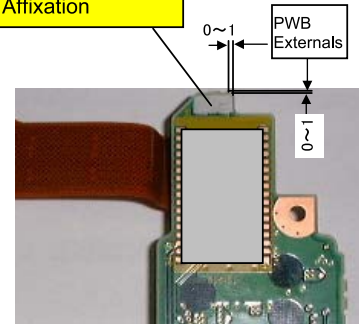
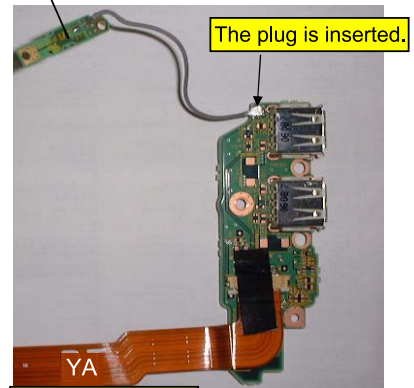

### 9.3.3.2. Putting MCH Sheet / Heat Spreader Bottom

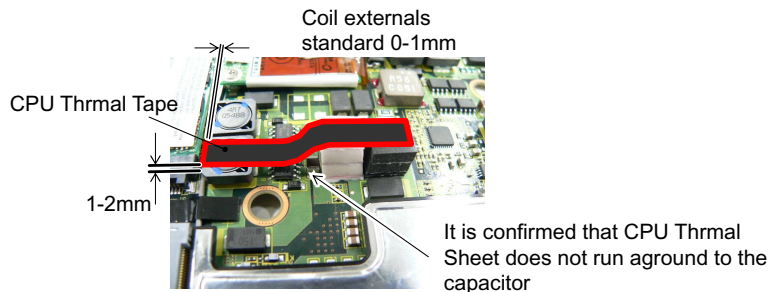
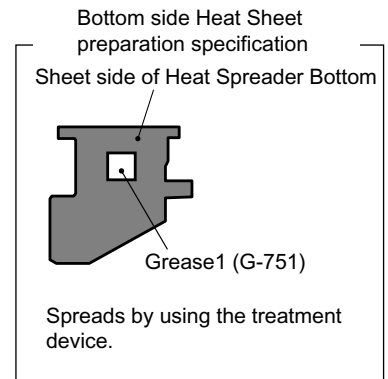
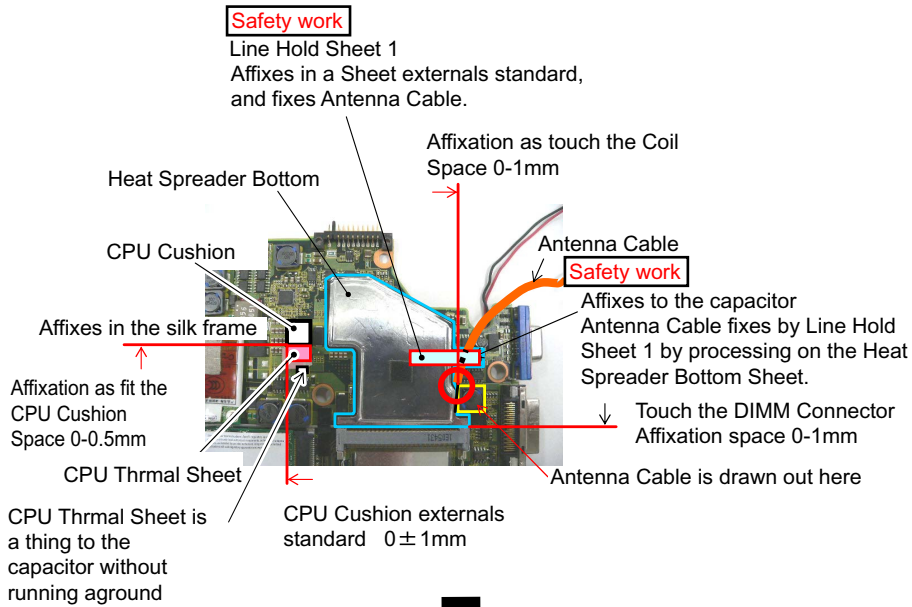
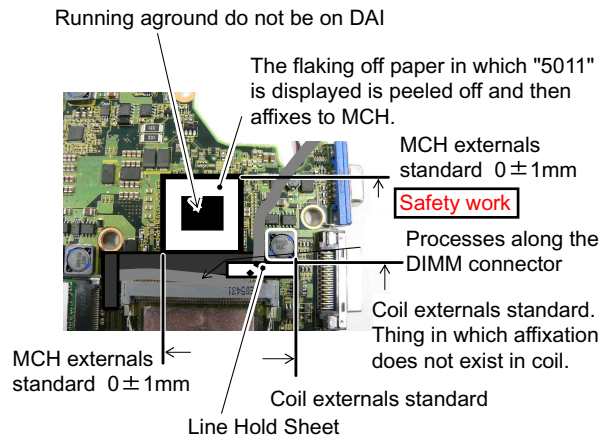

### 9.3.3.3. Assembly of the WLAN Sheet / MCH Thermal Tape

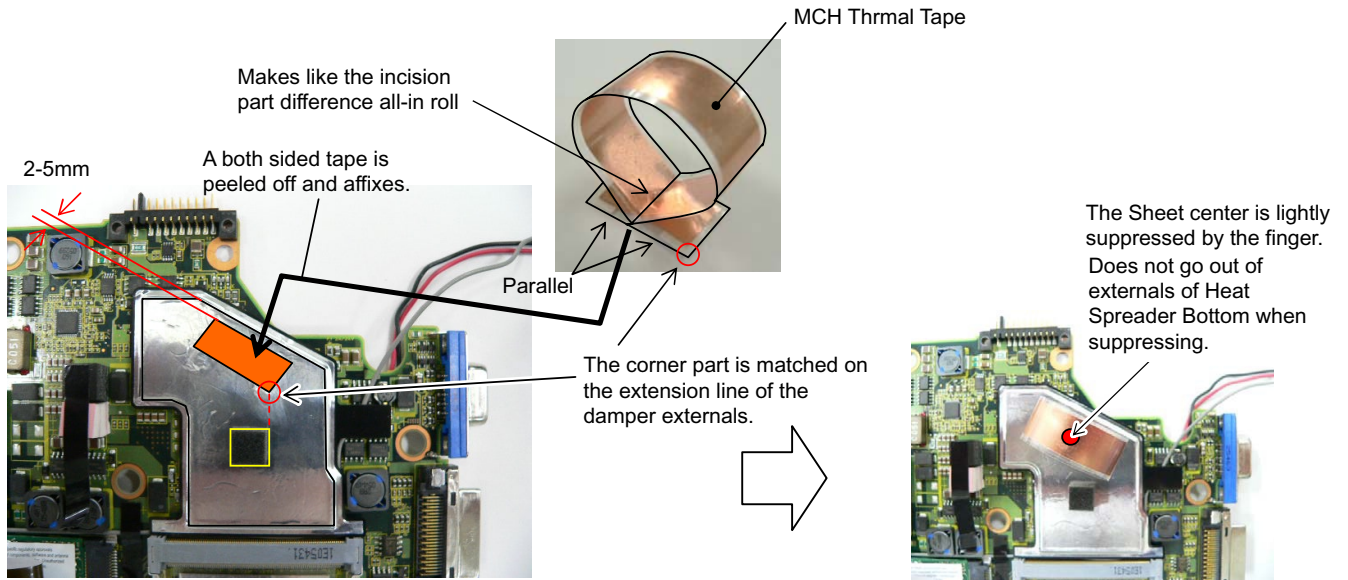
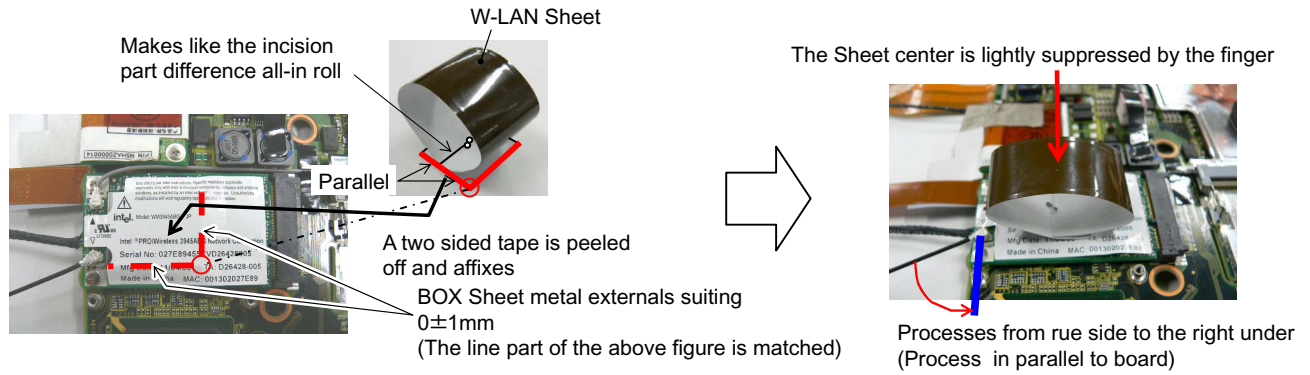

### 9.3.3.4. Assembly of the Main Board

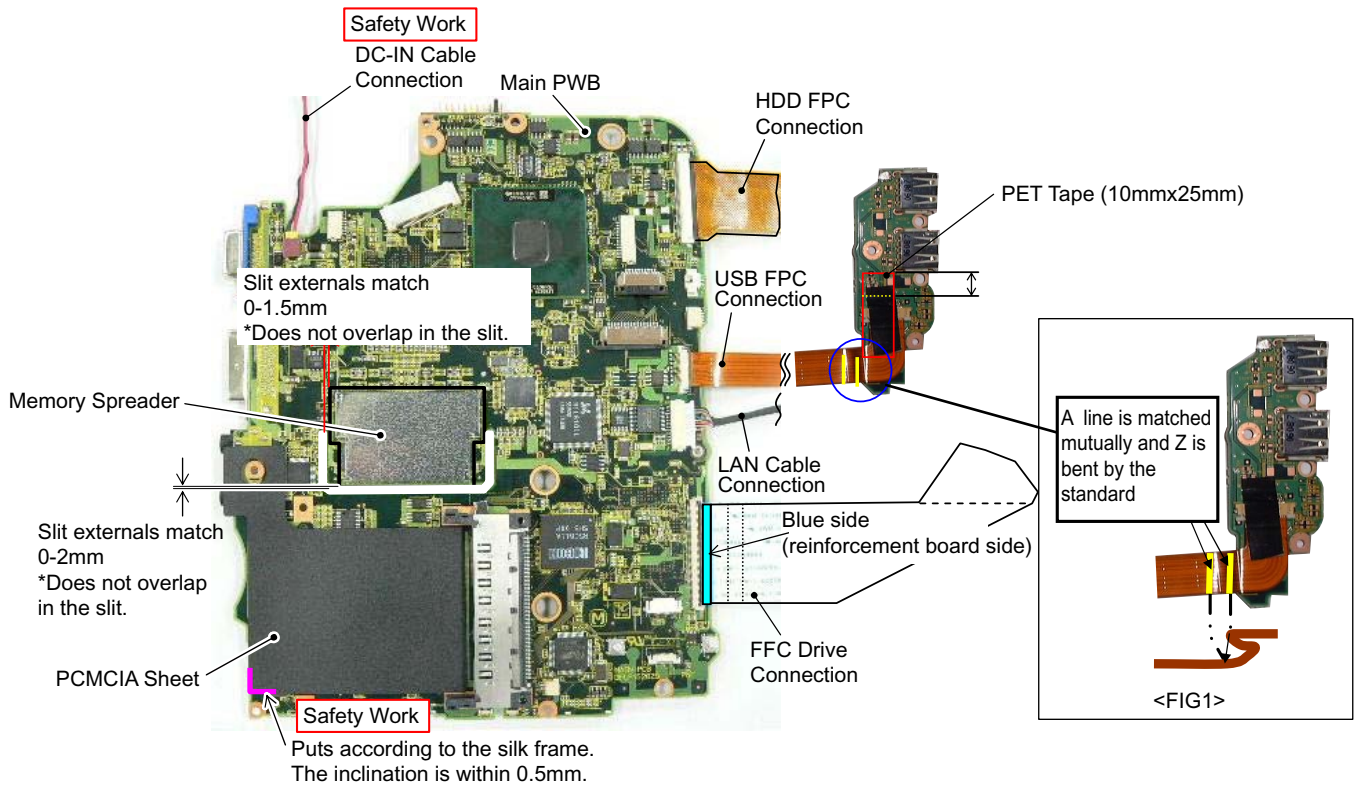

(Attention)

- The board is set in the receiving treatment device and works.
- The connector lock work after FPC is inserted uses the treatment device.



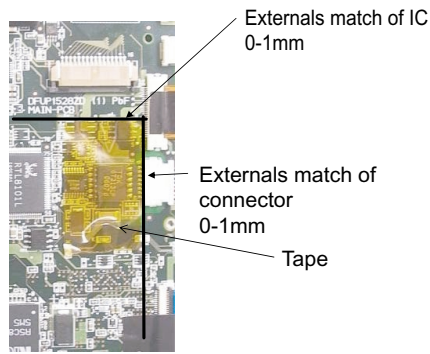

### 9.3.3.5. Assembly of the Card Bus Ejctor

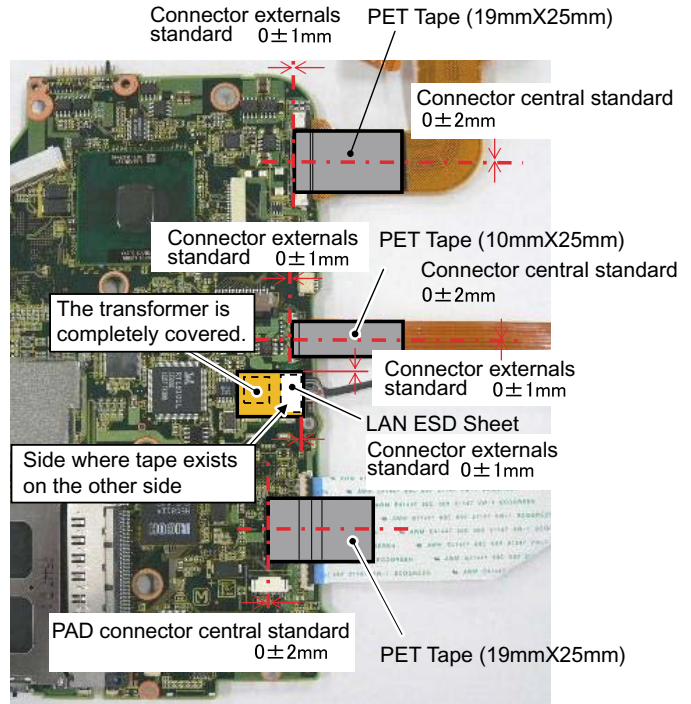
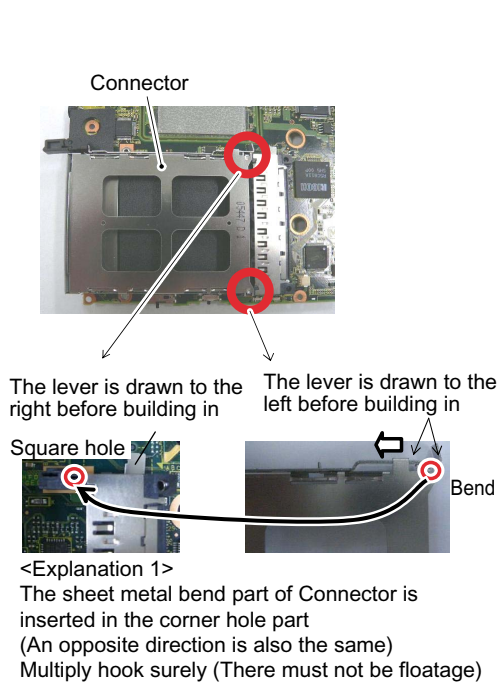



### 9.3.3.6. Assembly of the Wireless LAN Module / MODEM

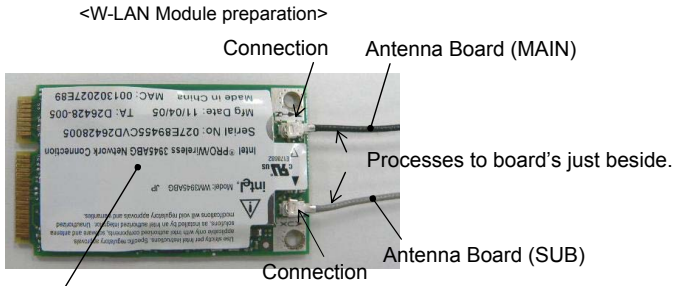

W-LAN Module

- Work in midair prohibition when module is connected with antenna board.
- Connects applying the board to the receiving stand.  
(For the distortion prevention of the board)

<MODEM preparation 1>

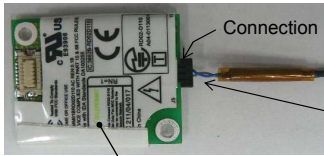

MODEM

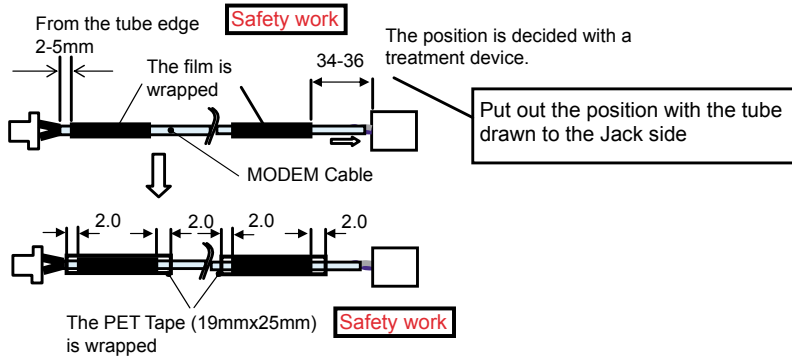

<MODEM preparation 2>

The remainder is affixed on an opposite side

Safety work

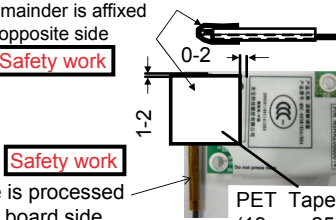

Cable is processed to the board side

Safety work

<MODEM preparation 3>

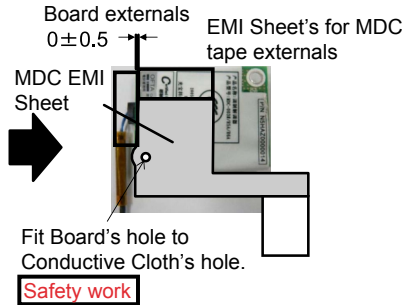

### 9.3.3.7. Insert the Main Board

(Attention)

- The board is set in the receiving treatment device and works.
- When carrying to the following process, a special palette is used.  
(The FPC bend in YB respect is prohibited)

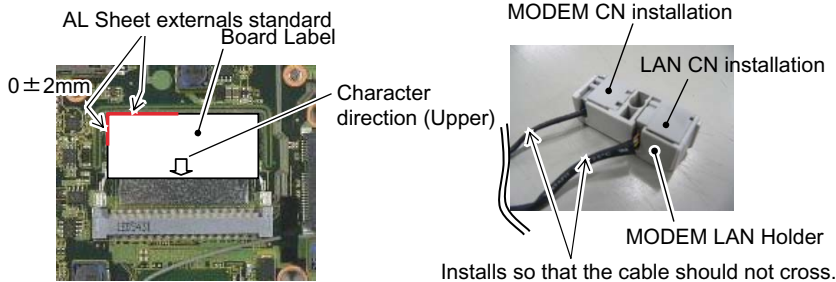
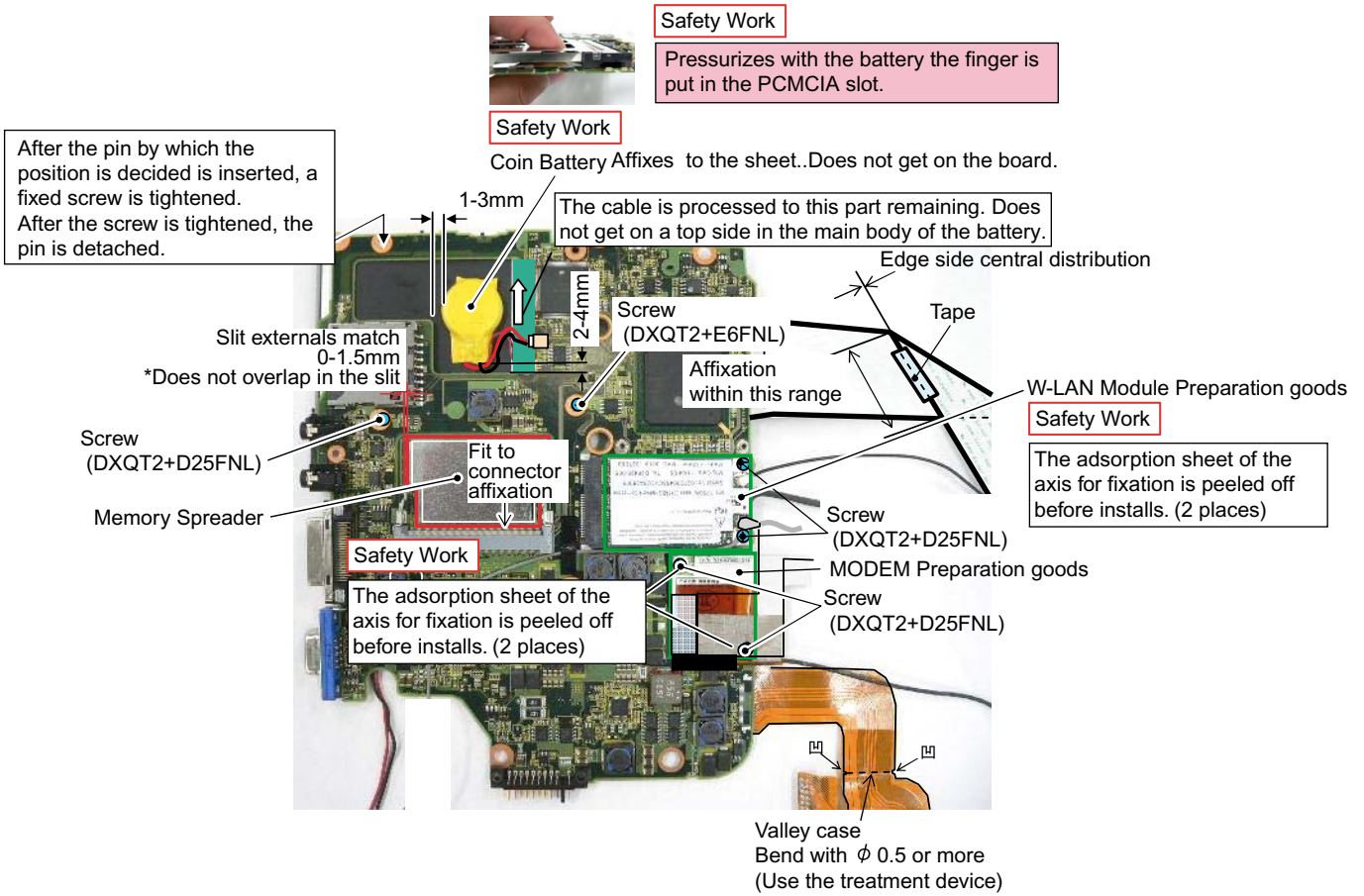

### 9.3.3.8. Note of Wireless LAN module is inserted

<Notes when Wireless LAN Module is inserted>

Please do Board's insertion and extraction correctly according to the direction and the procedure shown in the figure below

- ① Please go from parallel respect to mounting Board in Board's insertion and extraction within the range of  $5^{\circ}$ - $10^{\circ}$
- ② Please insert in the interior completely when you insert Board.

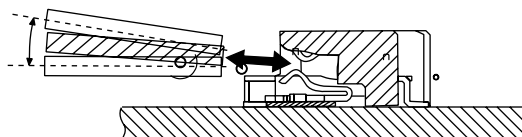

### 9.3.4. Assembly knowhow of the Top Case

#### 9.3.4.1. Assembly of the Disk Cover

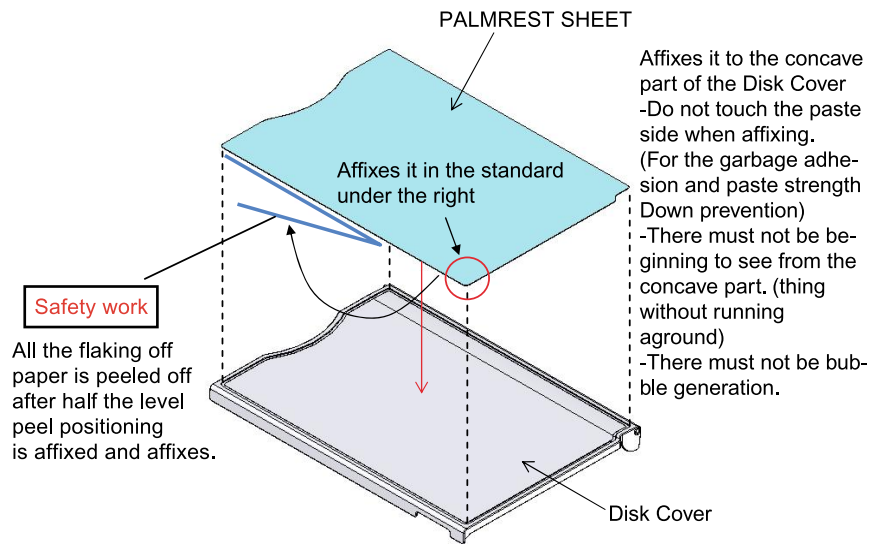
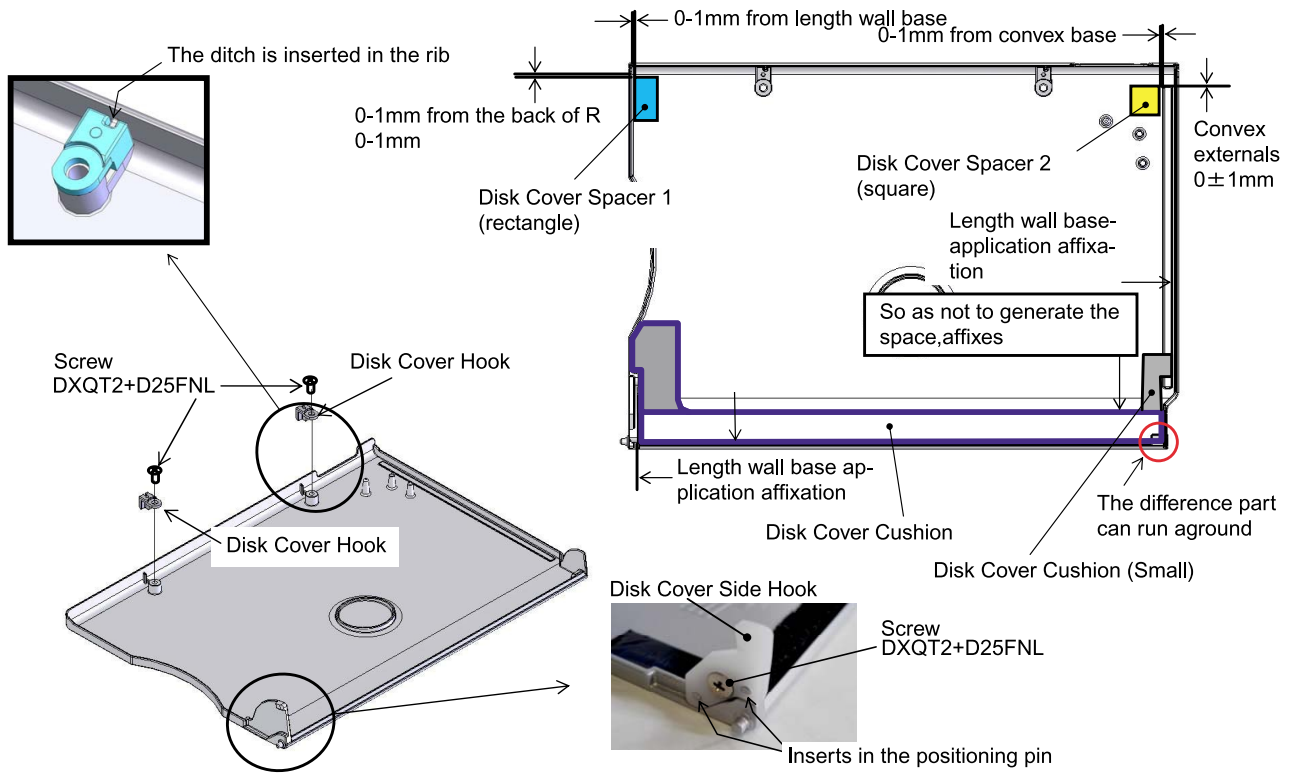

### 9.3.4.2. Putting Disk Angle Cushion

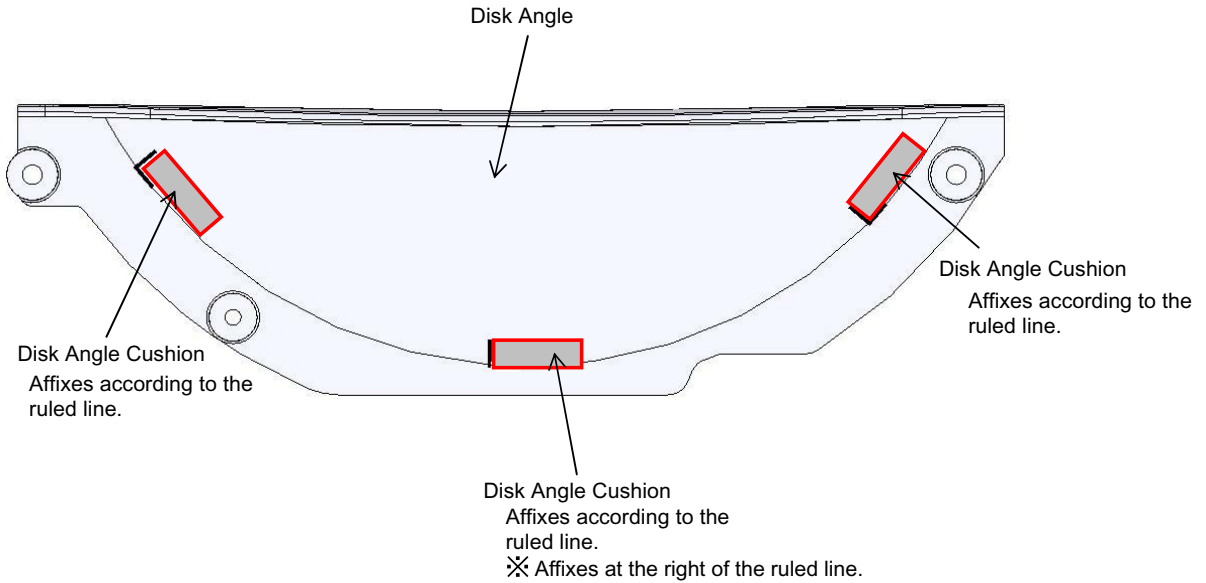

### 9.4.3.3. Assembly of the Top Case

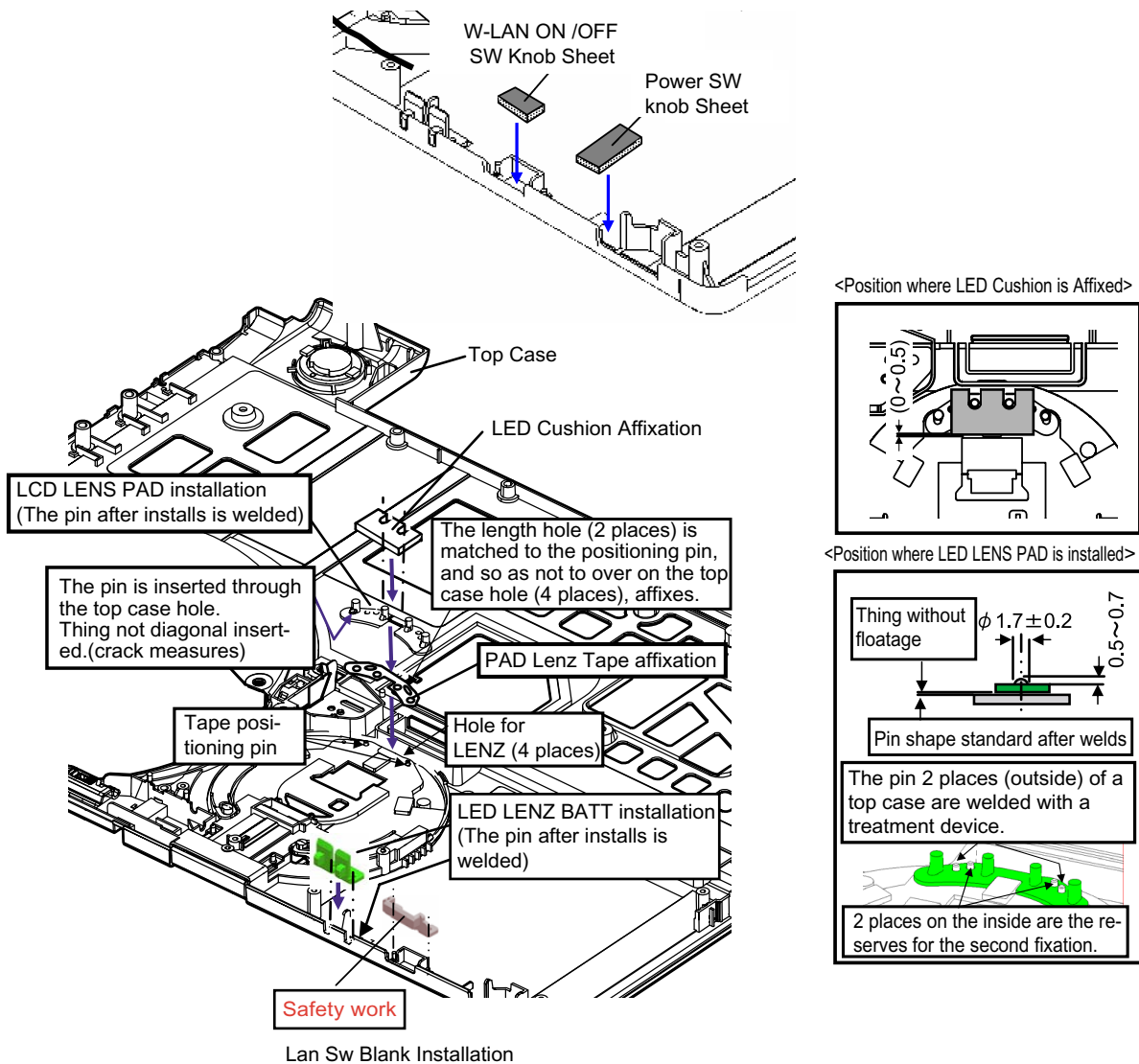

<Position where LED LENZ BATT is installed>

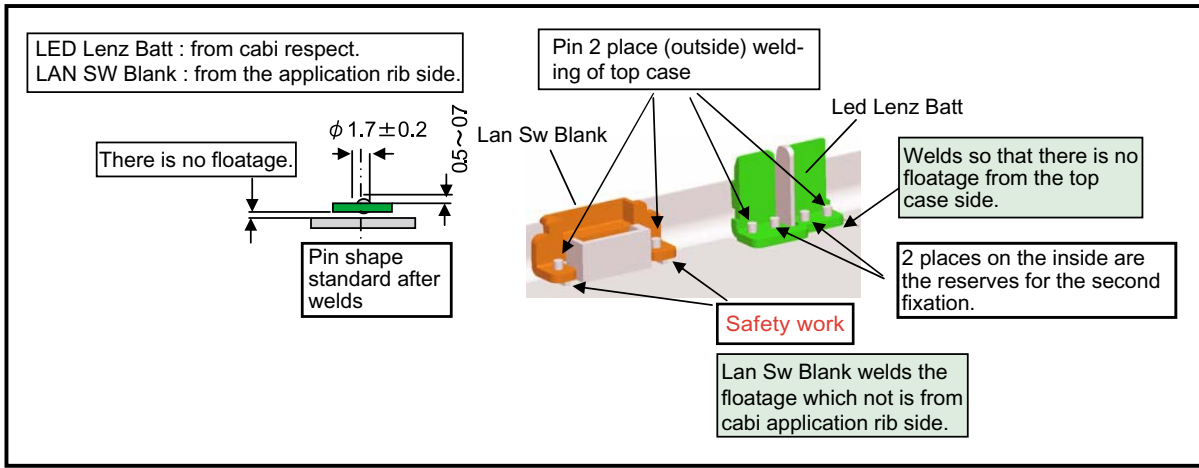

9.4.3.4. Assembly of the LCD Knob / Putting Cushion

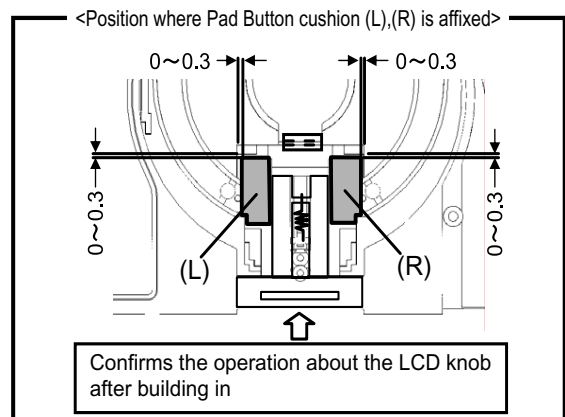
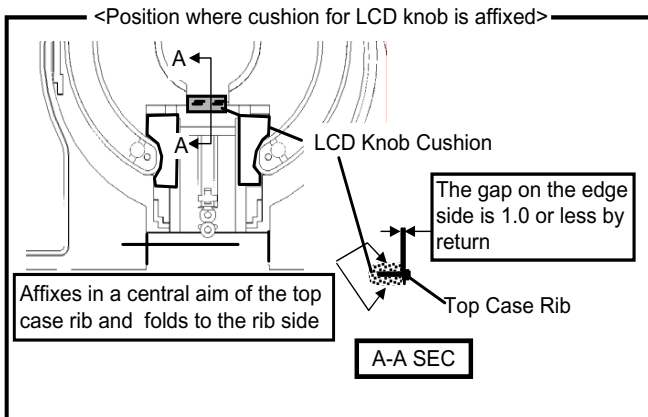
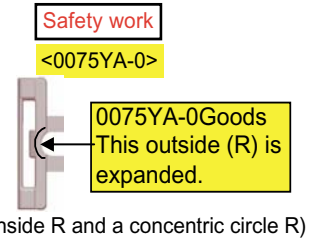
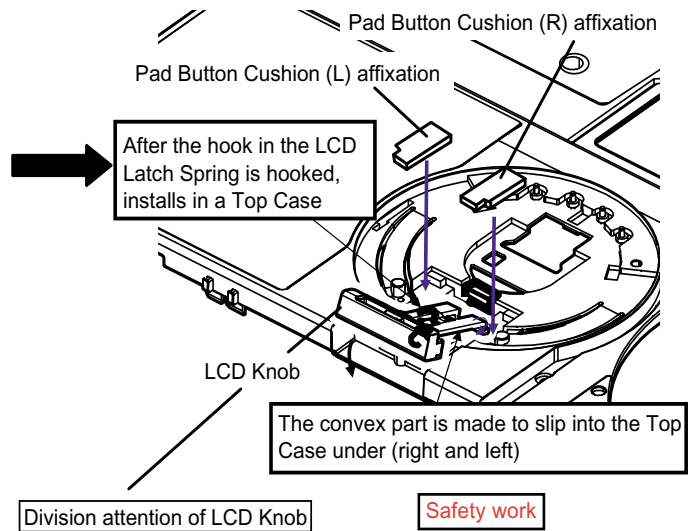
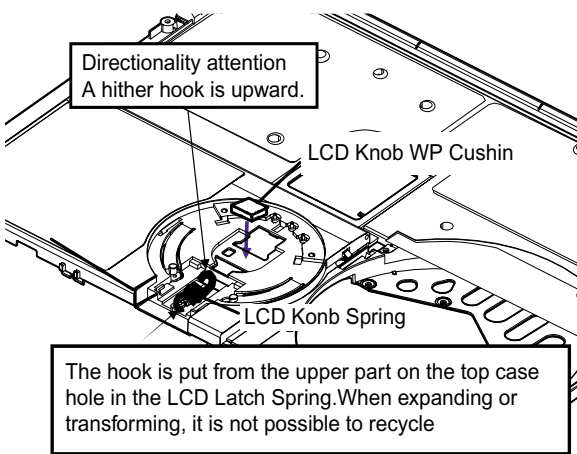

### 9.3.4.5. Assembly of the Touch Pad

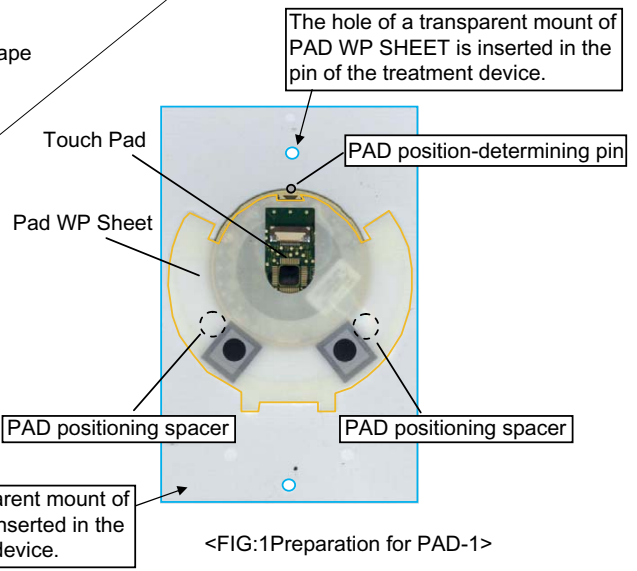
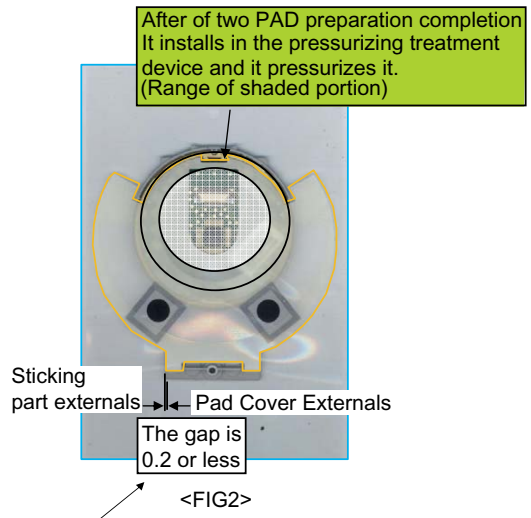
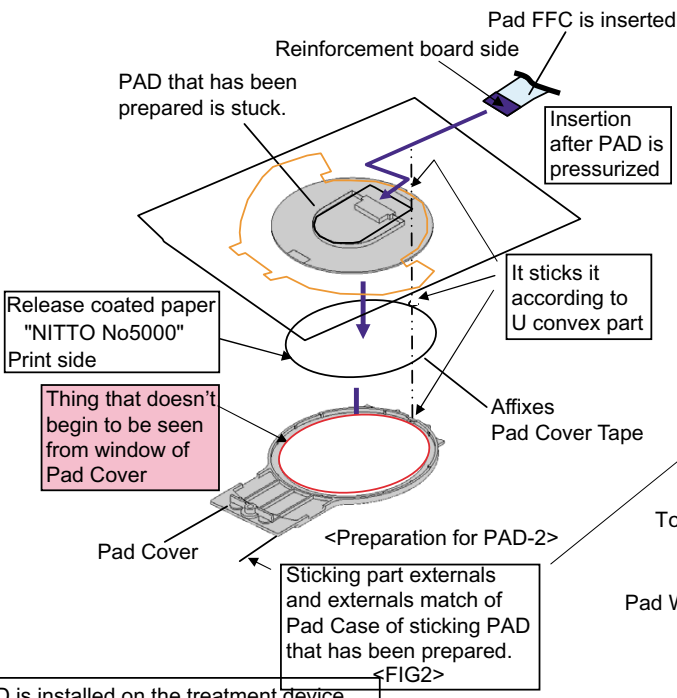
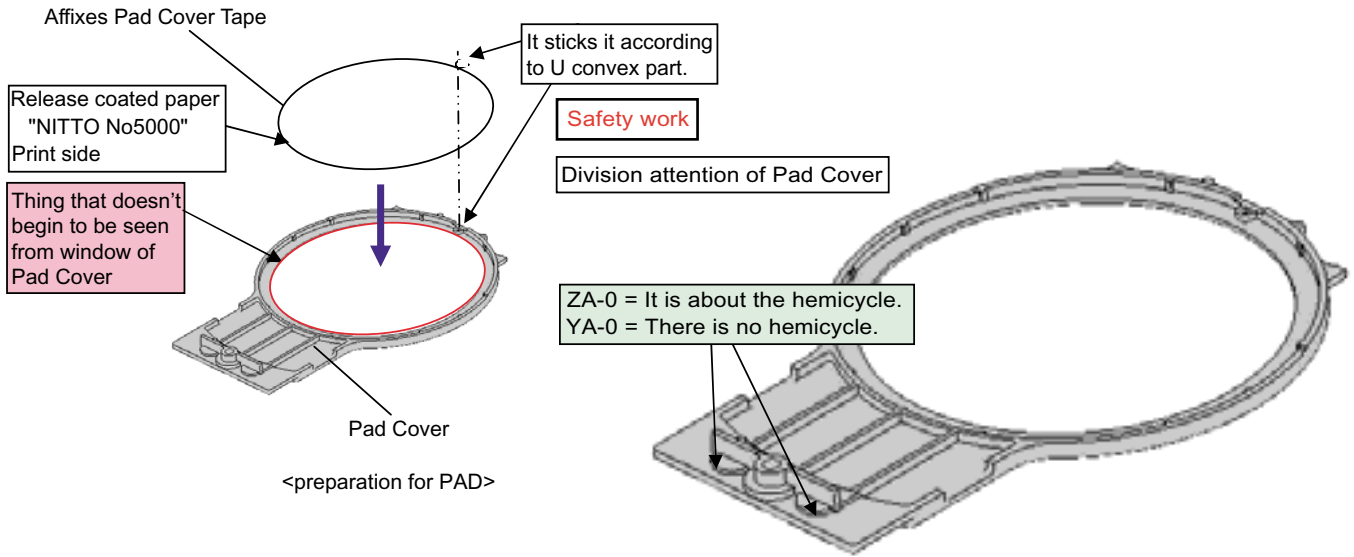

1. PAD is installed on the treatment device and it installs it between positioning the installation three places.
2. The yellowish brown flaking off paper side of Pad WS Sheet is peeled off and the positioning hole of a transparent mount is inserted in the pin of the treatment device.
3. The sticking part of PAD and WP Sheet is pressurized.



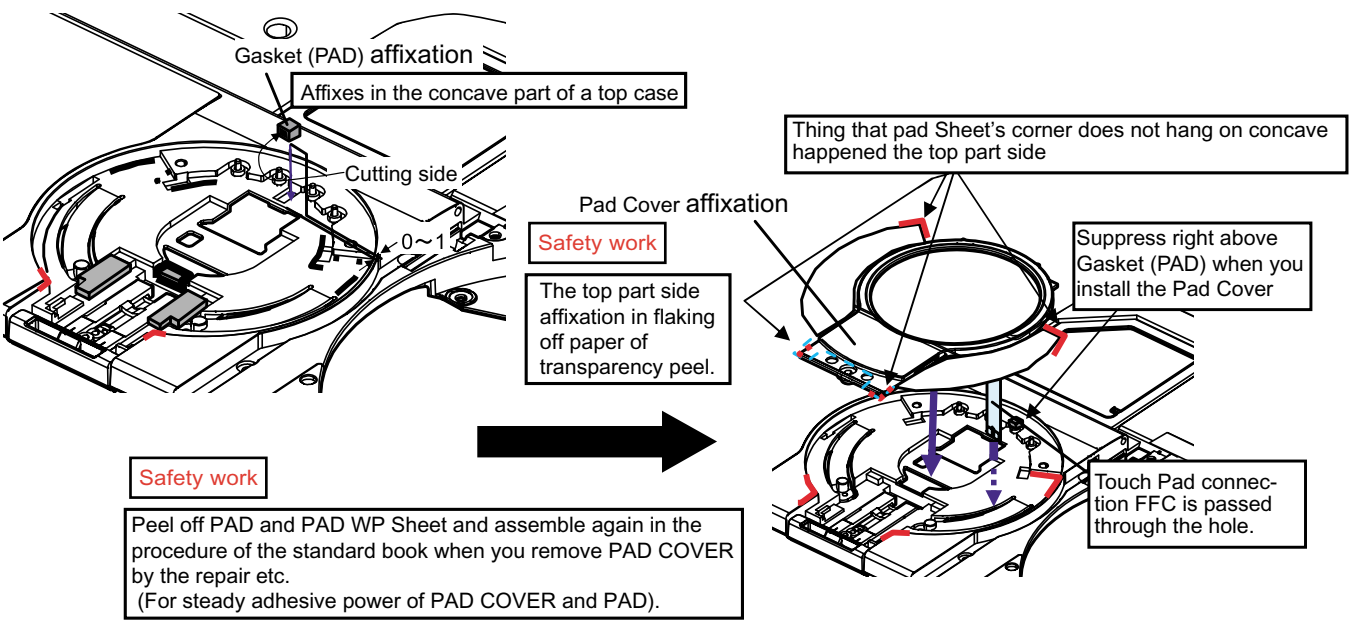
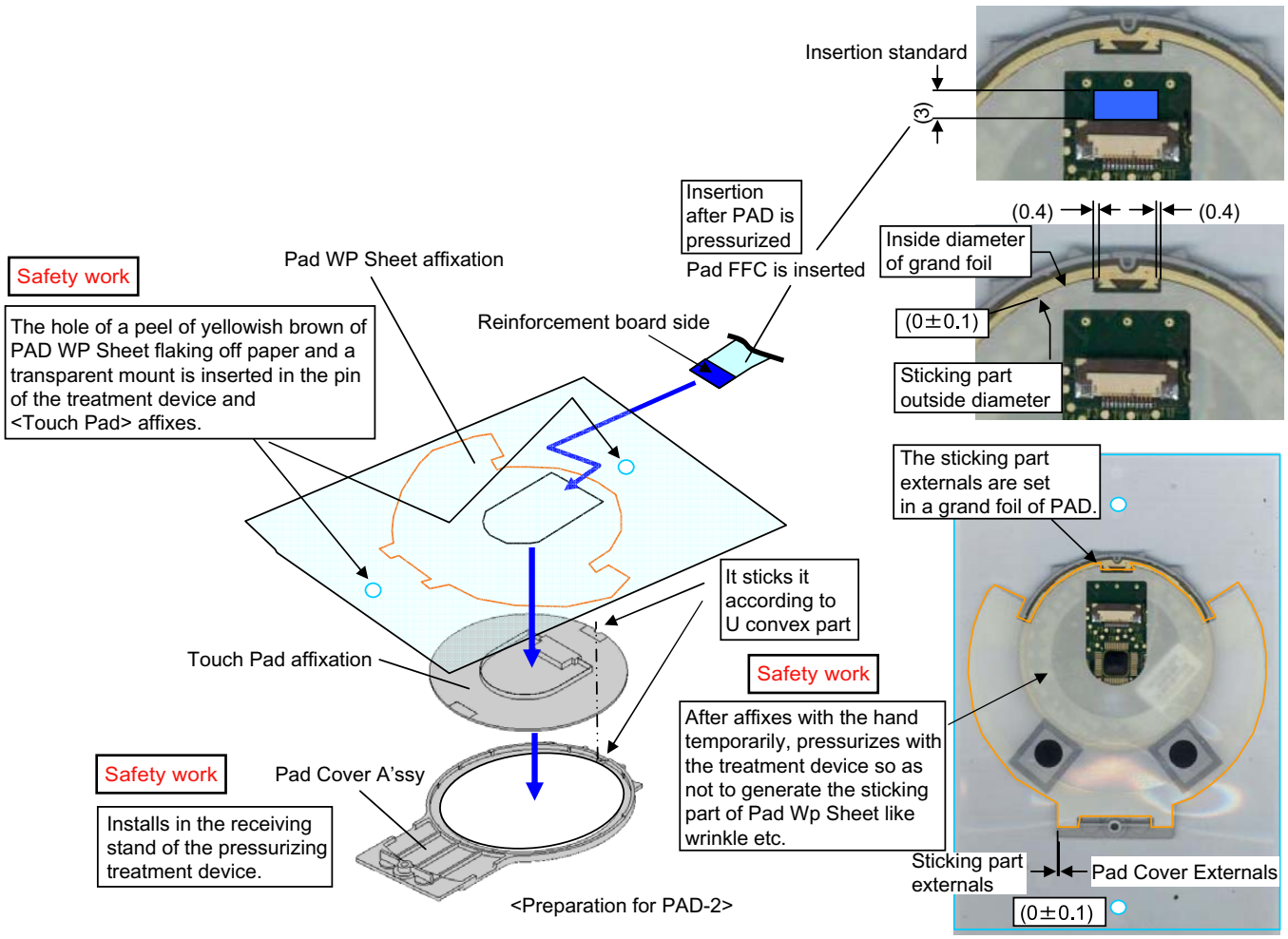

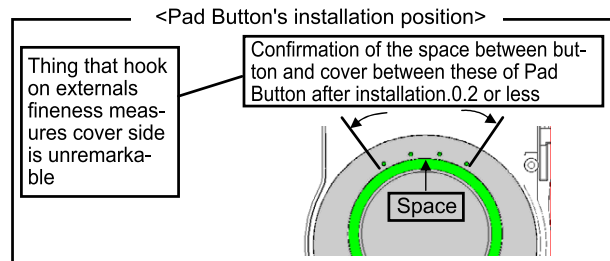
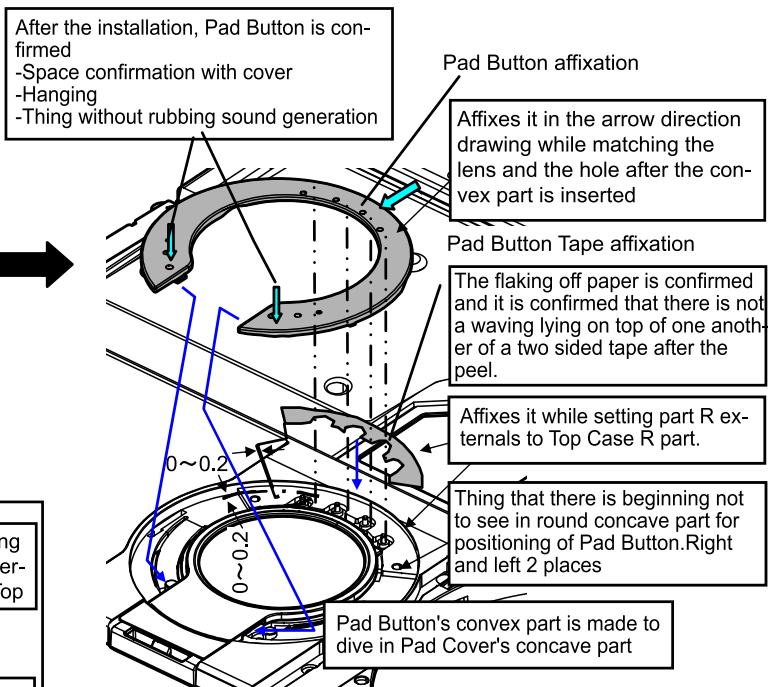
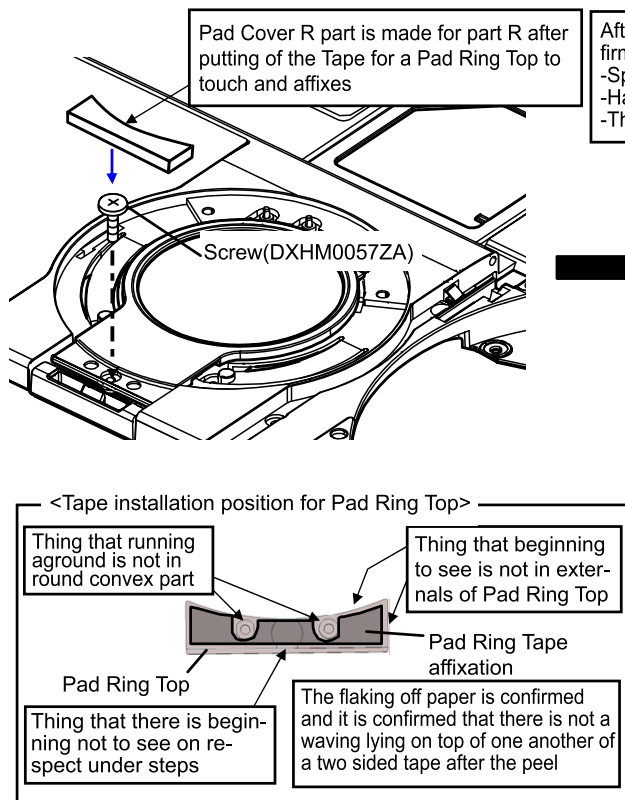
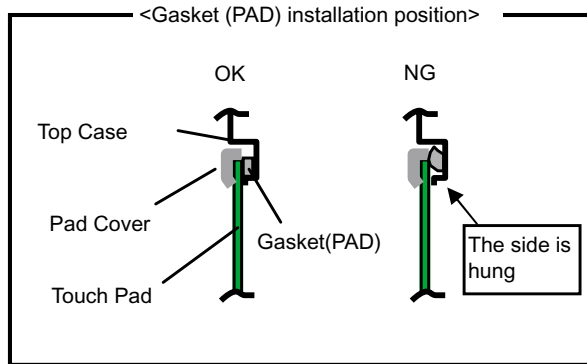
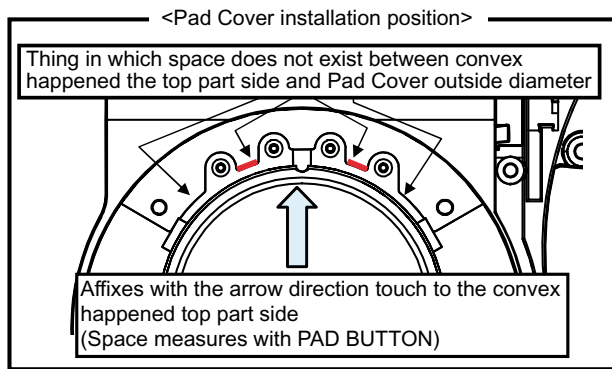



### 9.3.4.6. Putting Sheet

- Puts within the range in the concave happened top part.  
(It is confirmed that there is not running around.)
- Do not touch the paste side.  
(garbage adhesion and down of paste strength prevention)
- Thing without bubble generation
- Thing without lattice eyes transparent of paste confirmation
- From 0.5 or less to inclination 0.2 or less to concave bottom case part and seat externals space difference

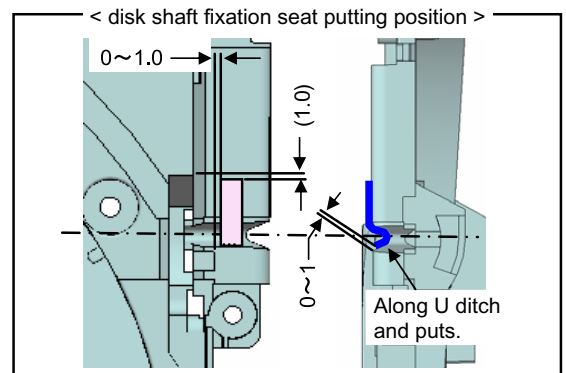
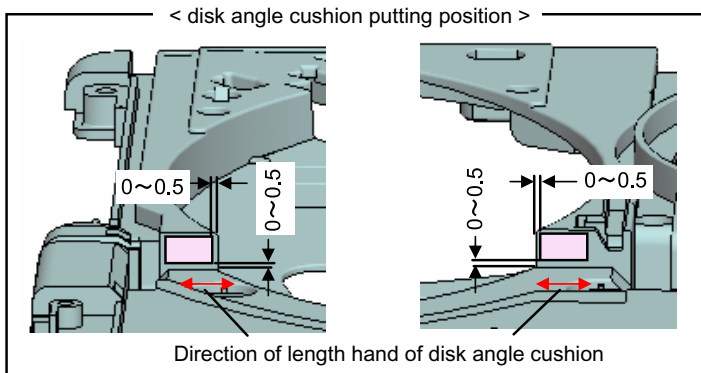
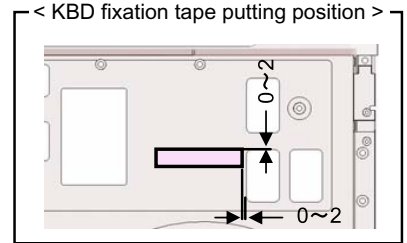
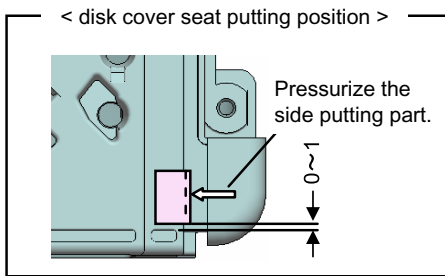
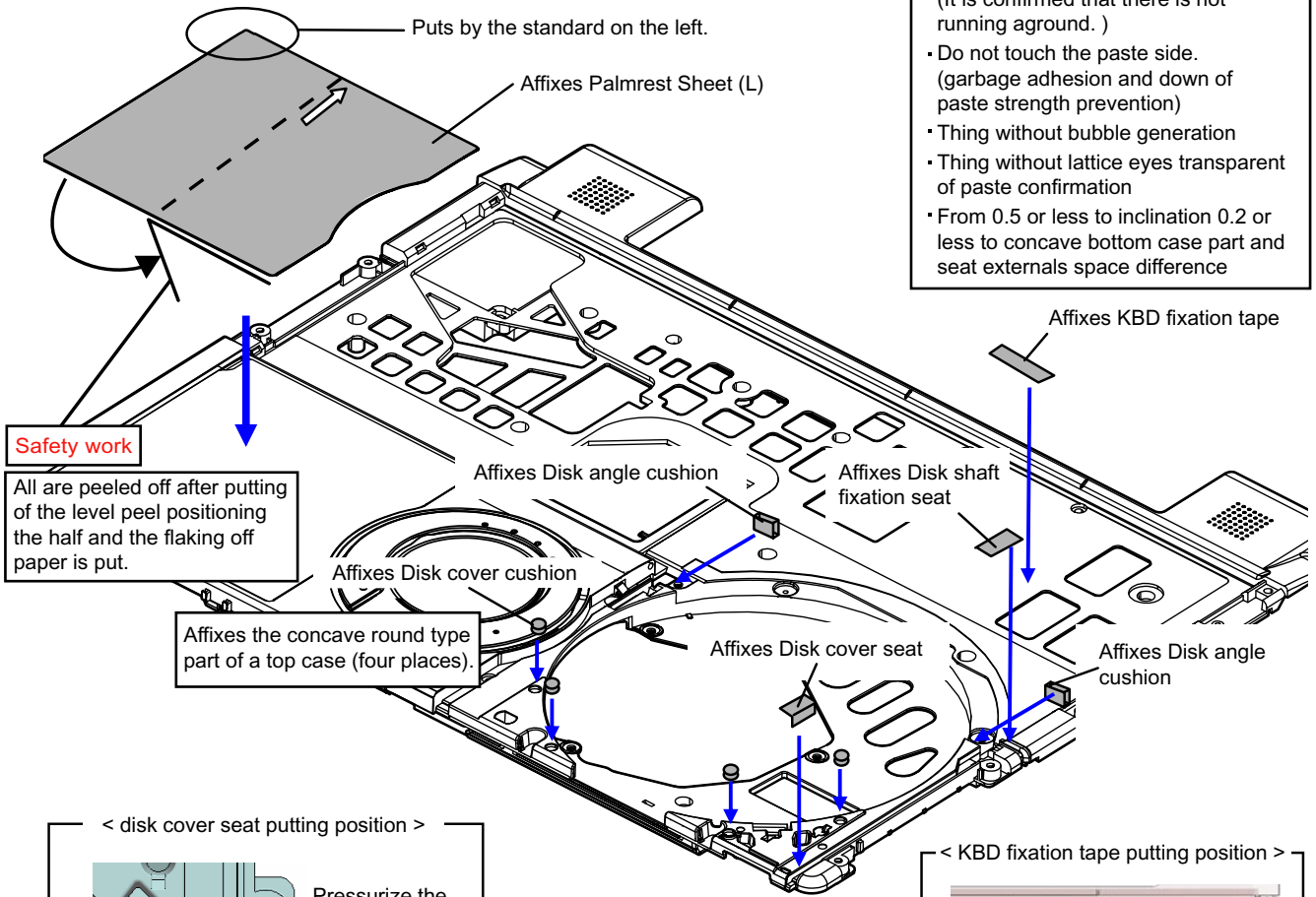

### 9.3.4.7. Assembly of the Break Lever

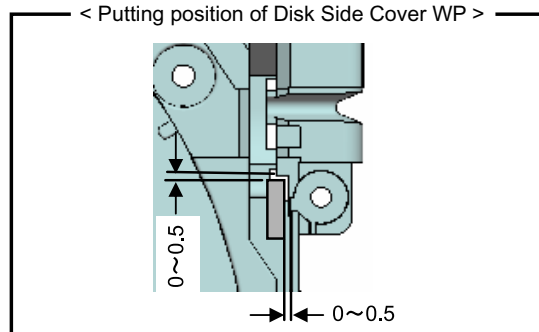
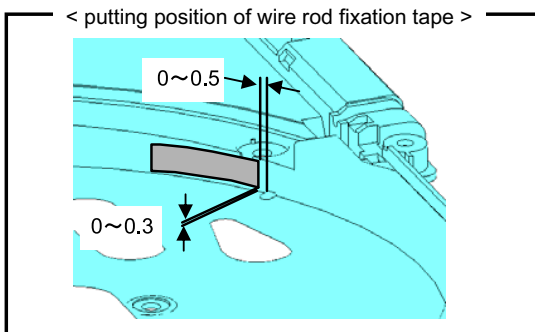
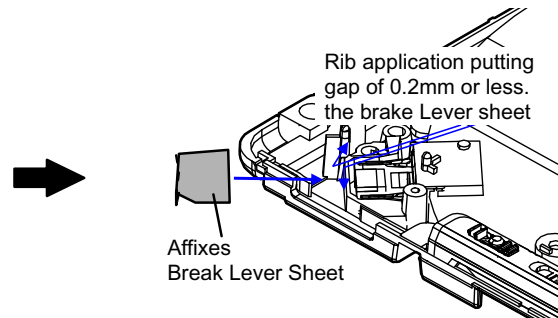
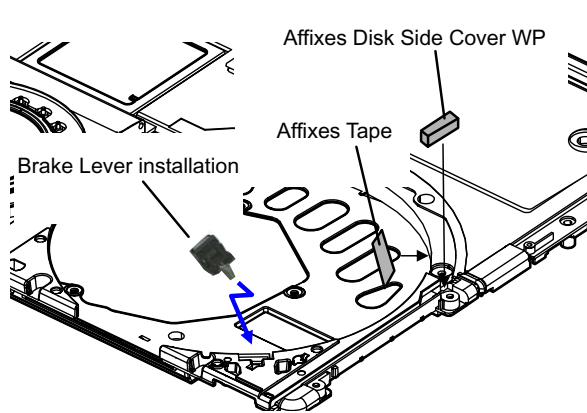
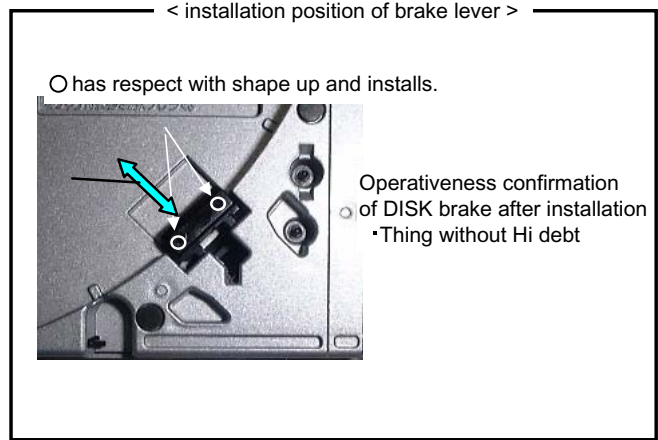
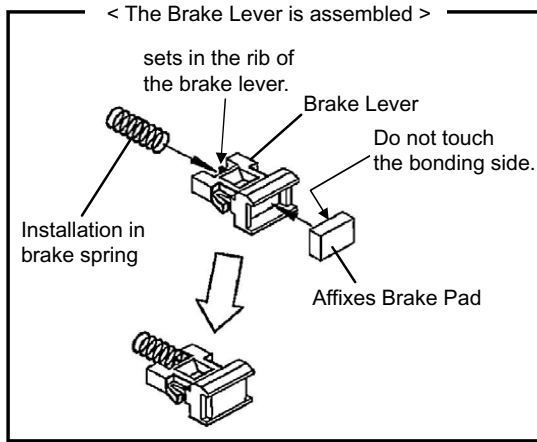

### 9.3.4.8. Assembly of the FAN

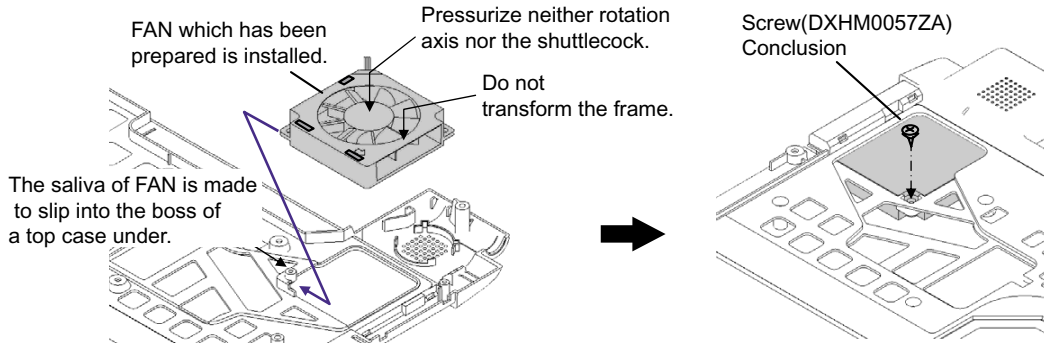
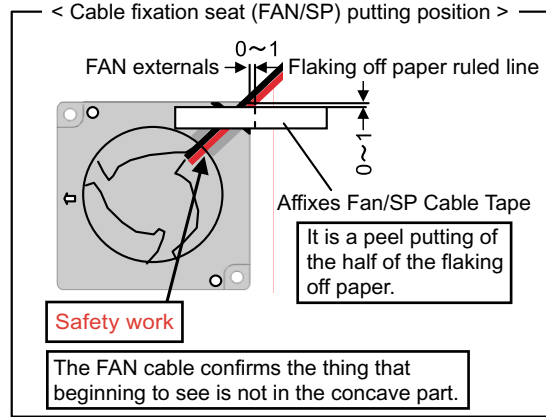
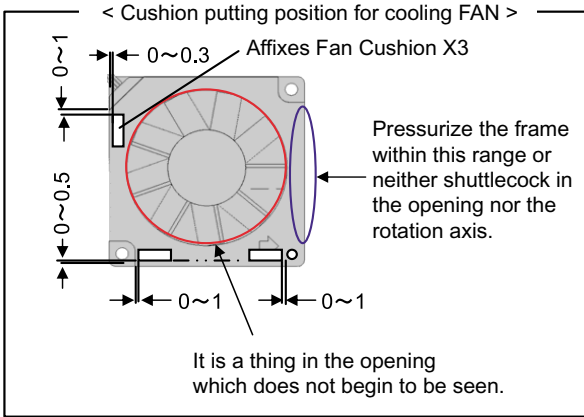

**\* Work notes**

1. FAN must not be dropped, and do not add the impact.
- < SCWER tightening torque >  
 Conclusion first time power : 0.16-0.18N.m {1.6-1.8kgf.cm}  
 At the repair : 0.10-0.12N.m {1.0-1.2kgf.cm}

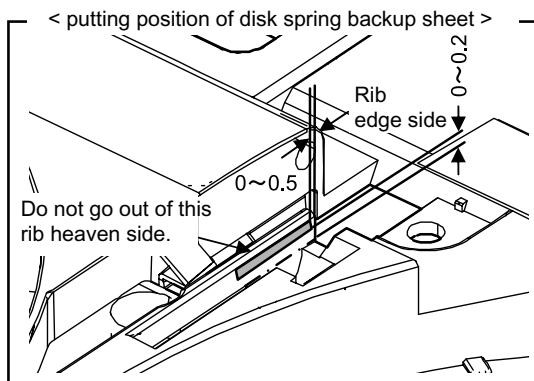
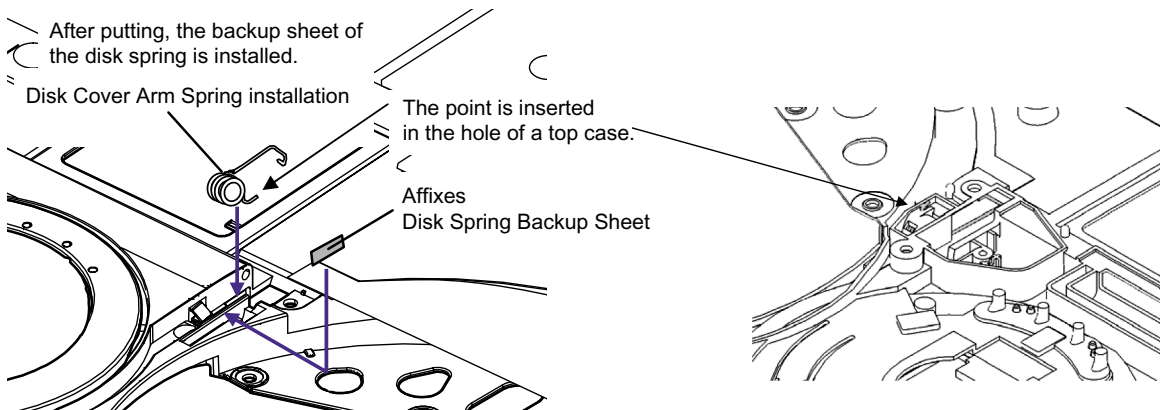

### 9.3.4.9. Assembly of the Disk Cover Click

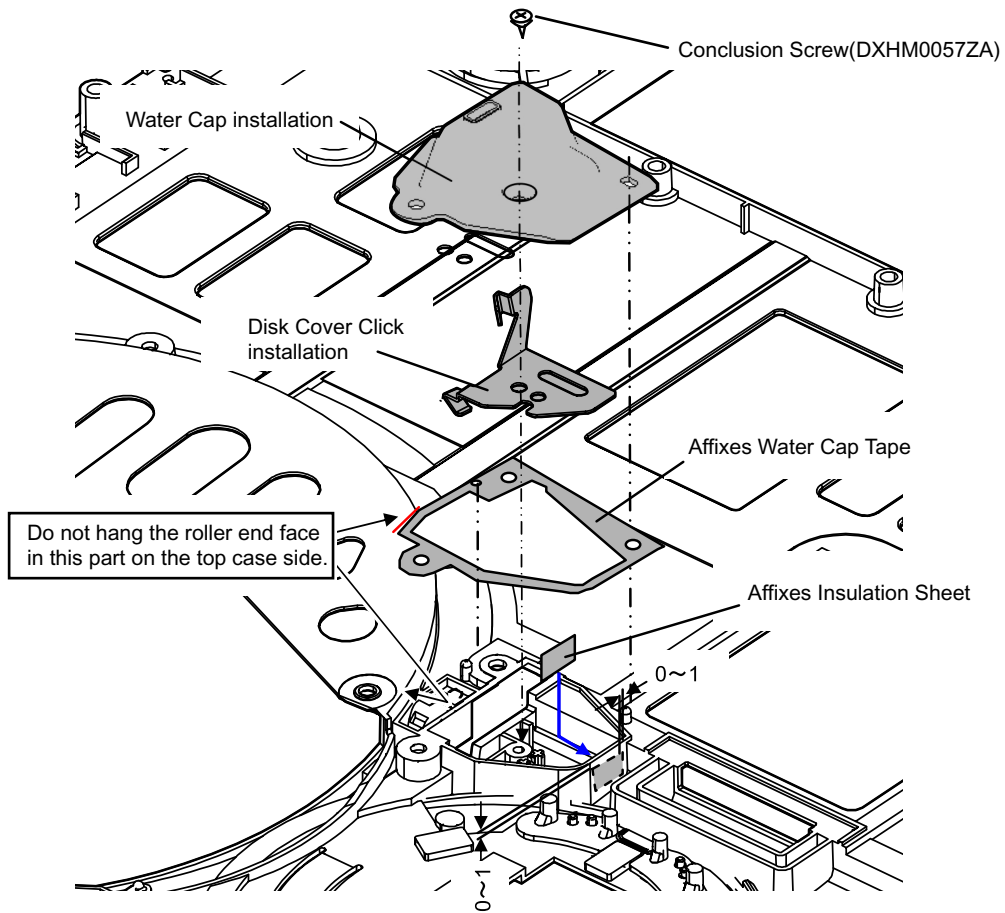

### 9.3.4.10. Assembly of the Disk Cover Lock / SW PCB

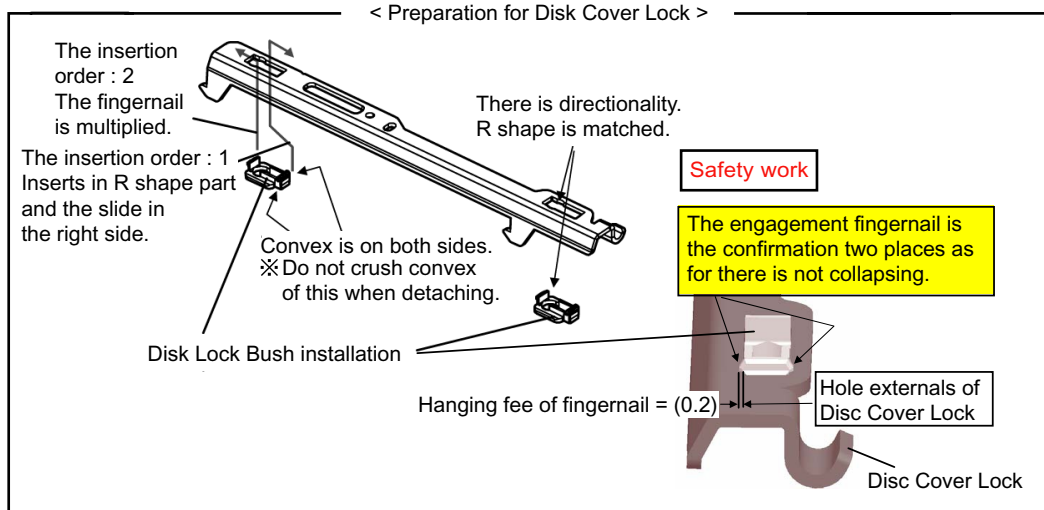
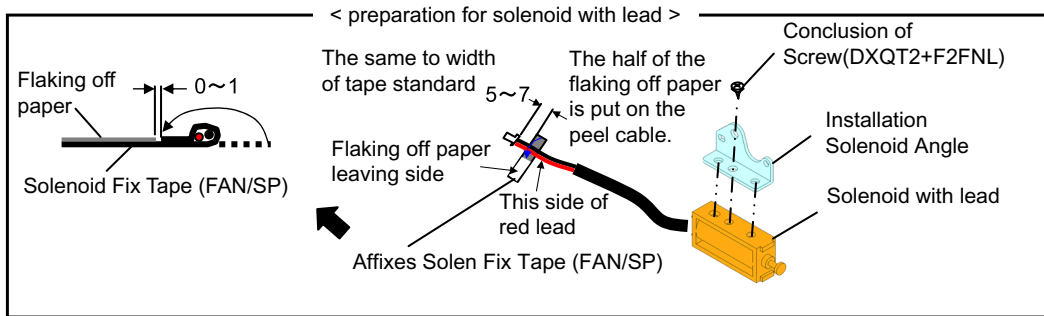

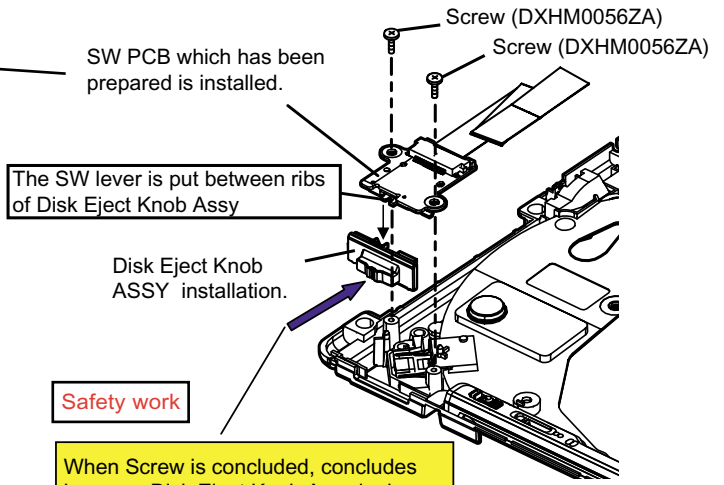
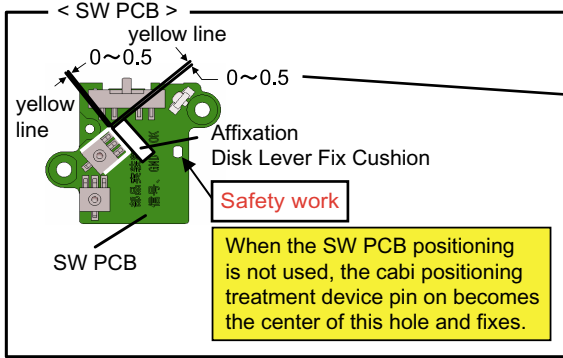

**Safety work**

When Screw is concluded, concludes because Disk Eject Konb Assy is drawn in the arrow direction.

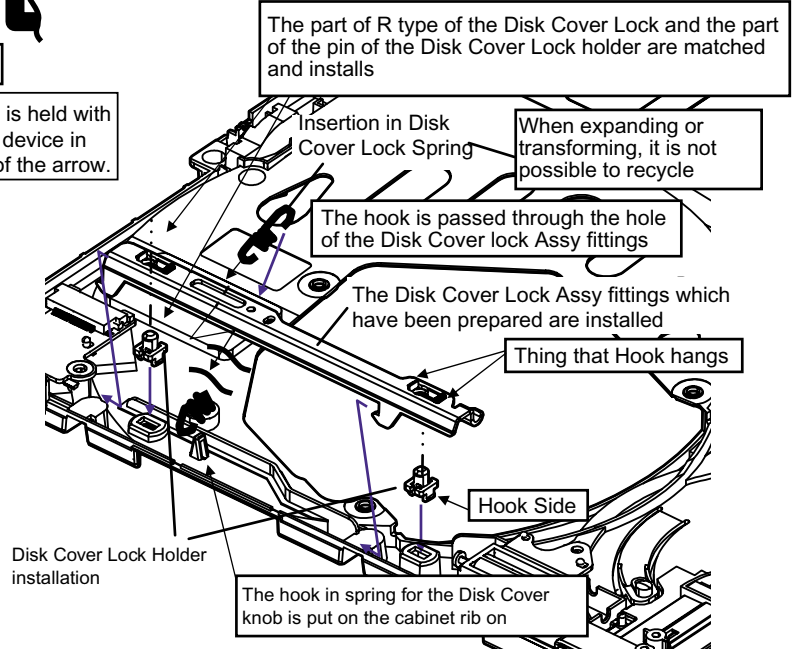
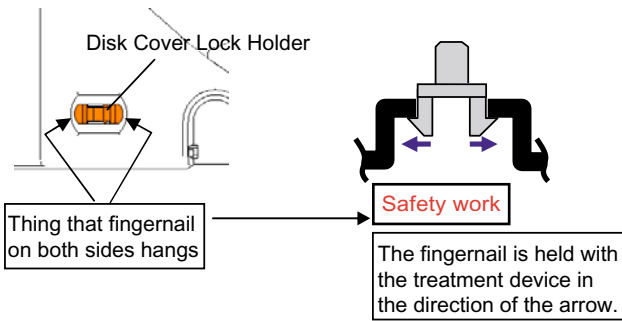
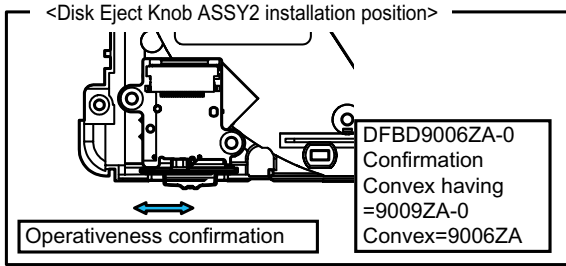

### 9.3.4.11. Assembly of the Solenoid

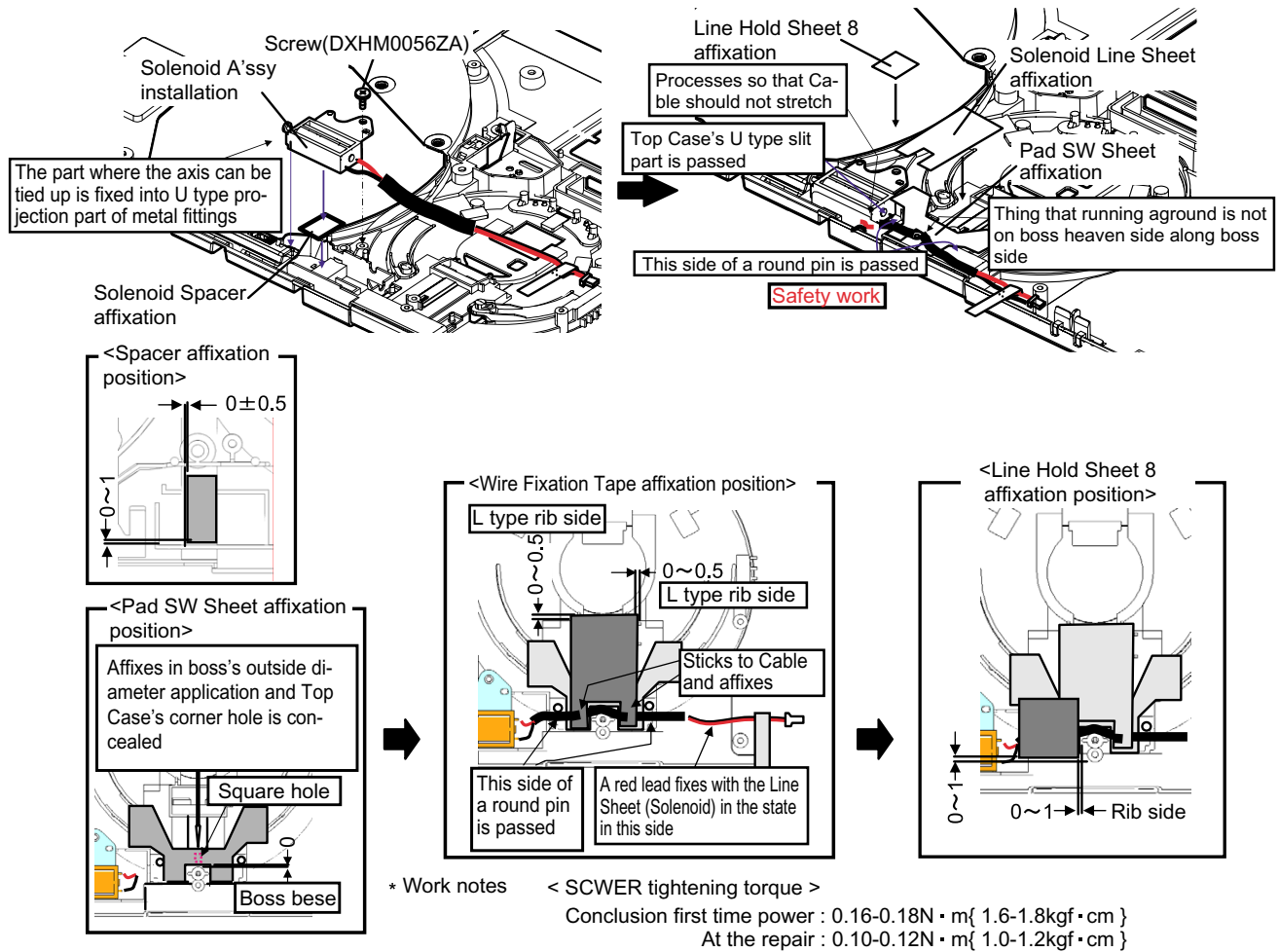

### 9.3.4.12. Assembly of the Speaker

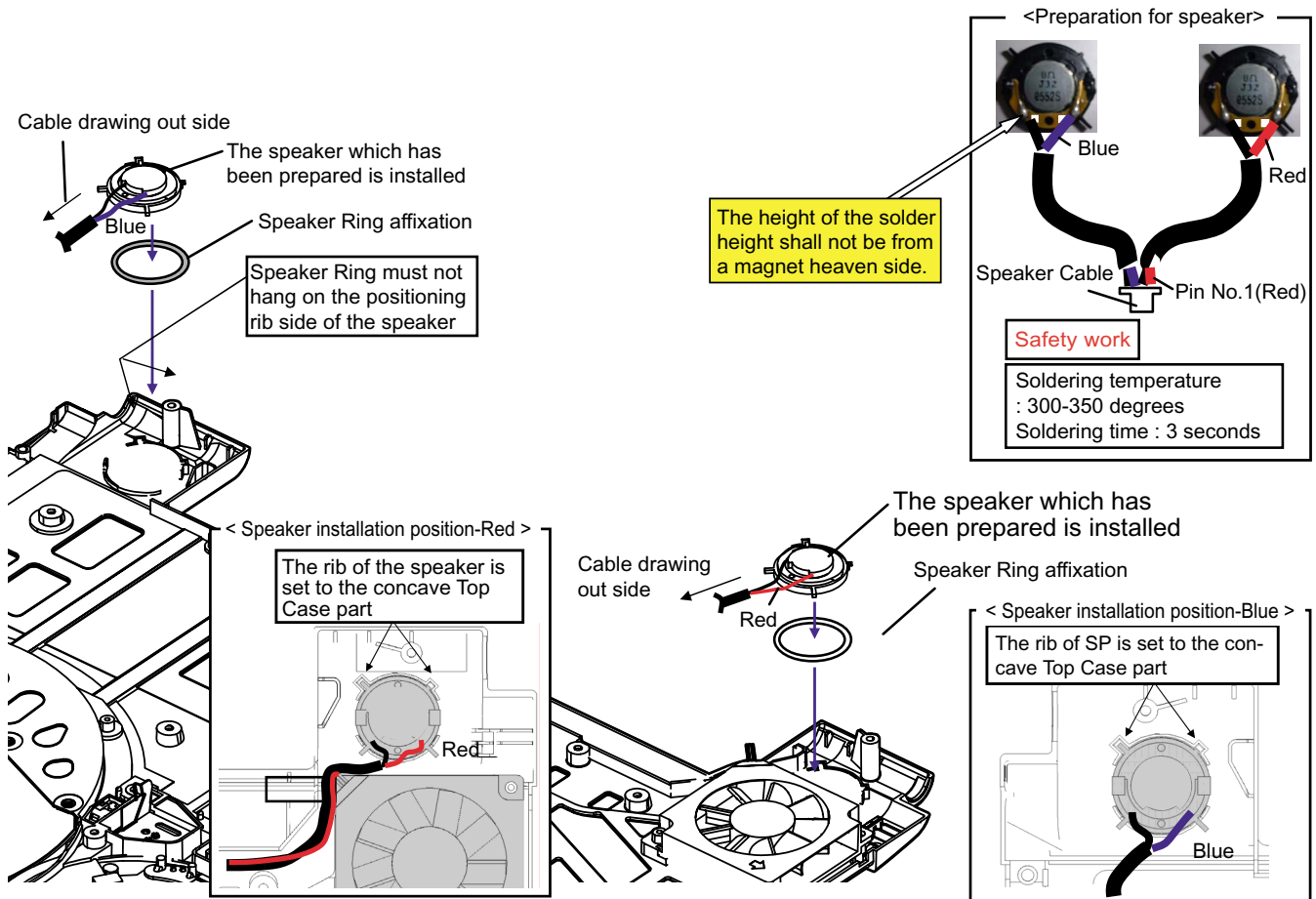



### 9.3.4.13. Wiring Speaker Cable

<Processing of SP/FAN Cable>

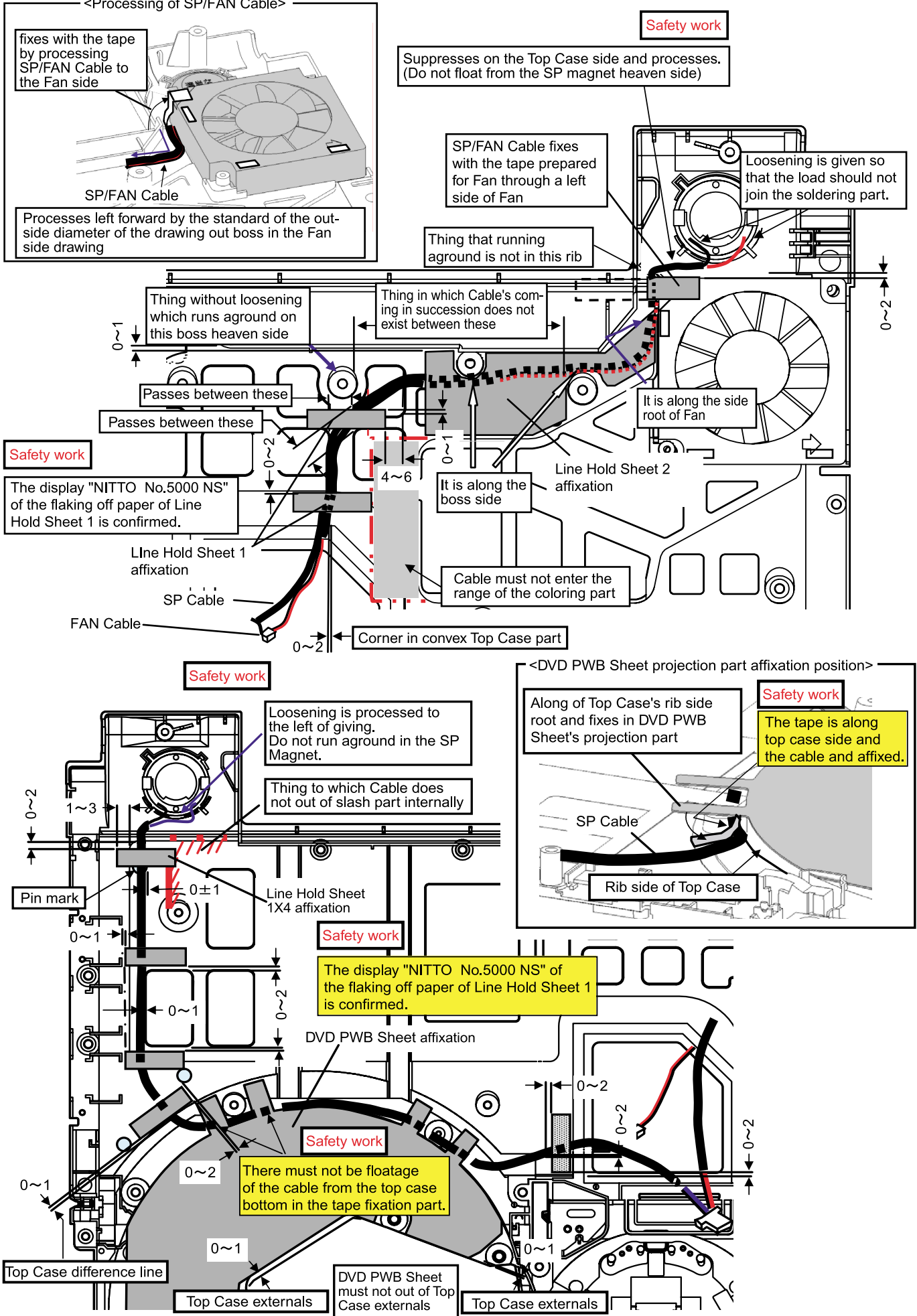

### 9.3.4.14. Putting Cushion / Tape / Sheet

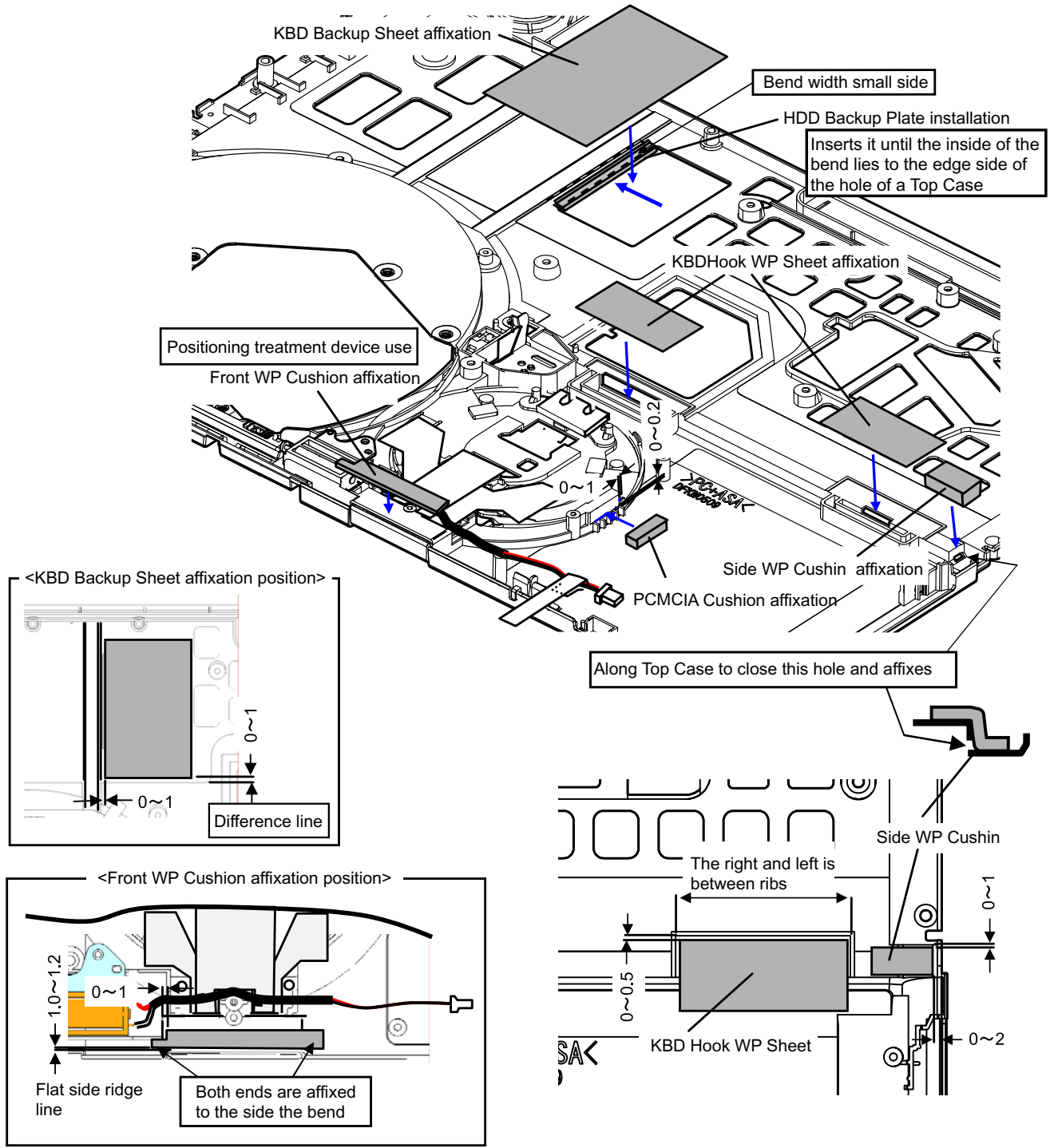



### 9.3.4.15. Assembly of the SW PCB FFC

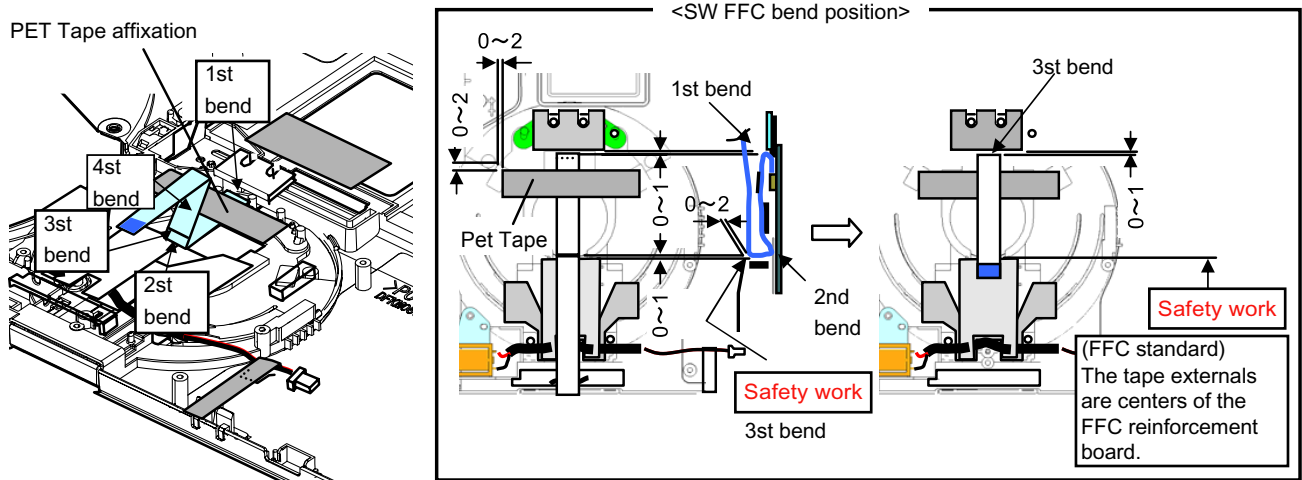
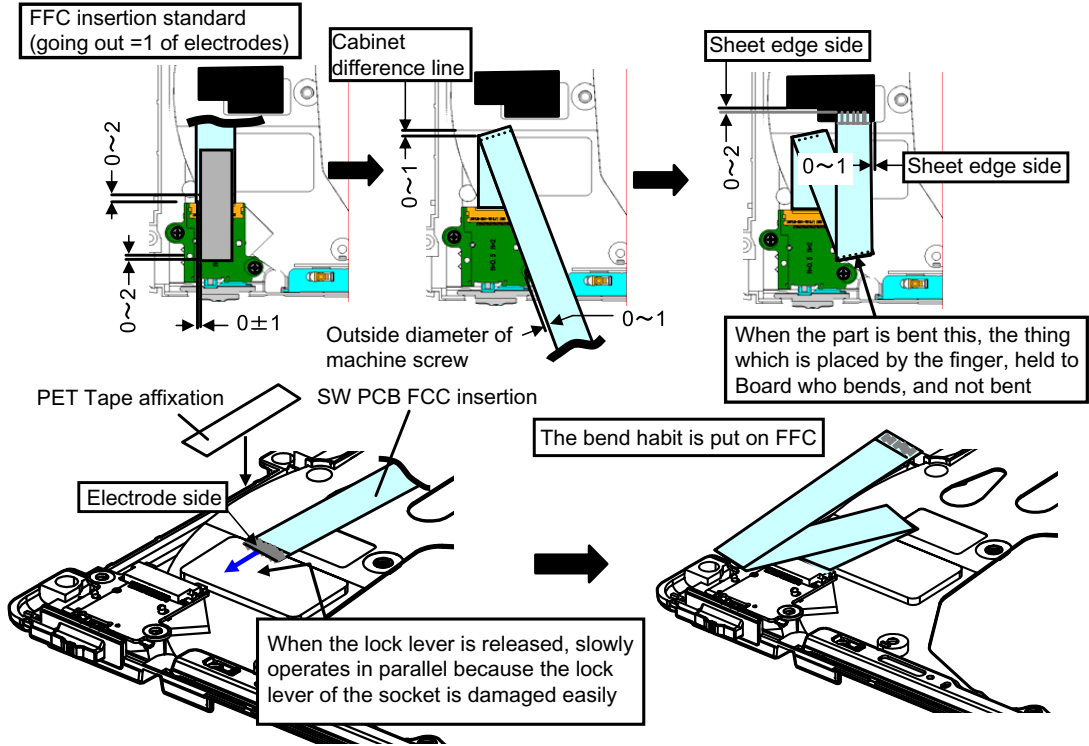

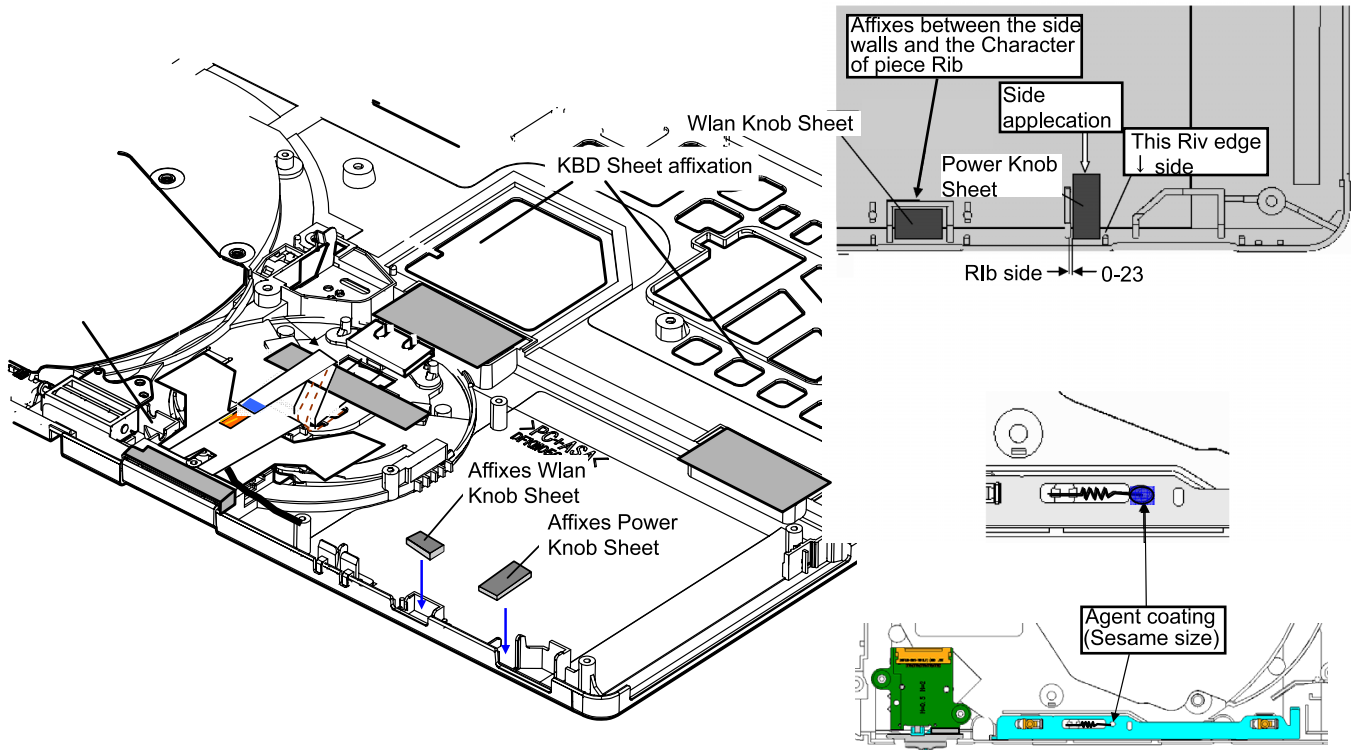

### 9.3.5. Assembly knowhow of the Bottom Case

#### 9.3.5.1. Putting Line Hold Sheet

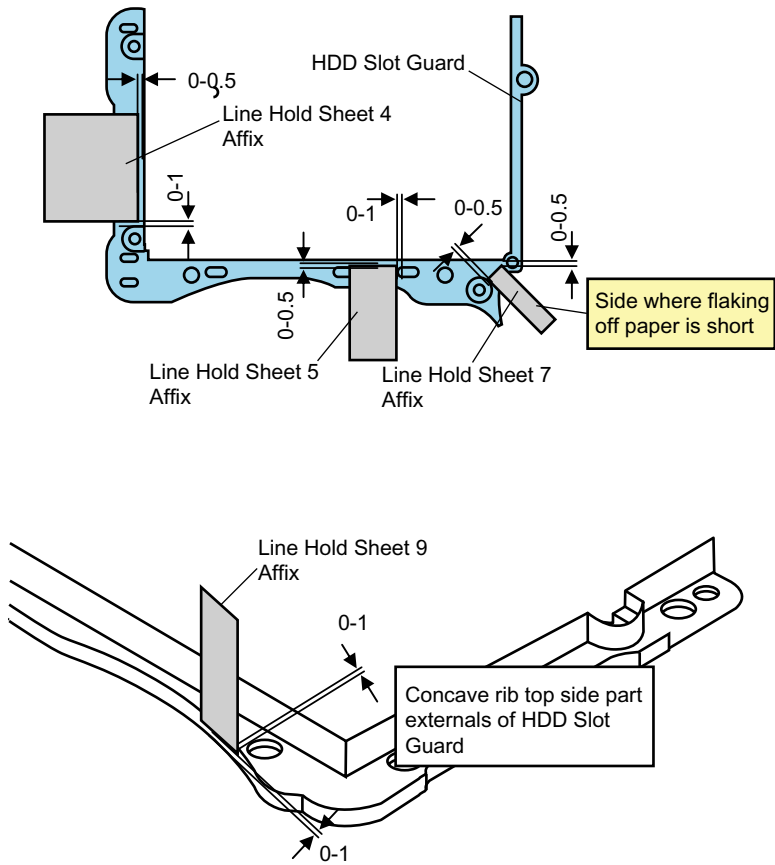

#### 9.3.5.2. Assembly of the DIMM Cover

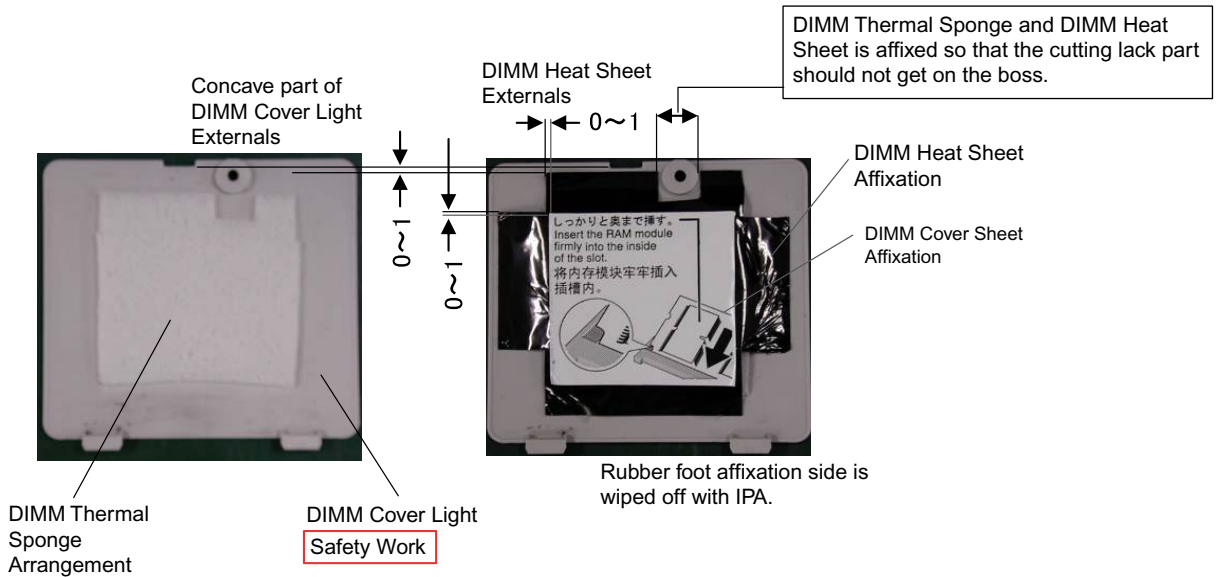

### 9.3.5.3. Putting Sheet / Cushion / Tape

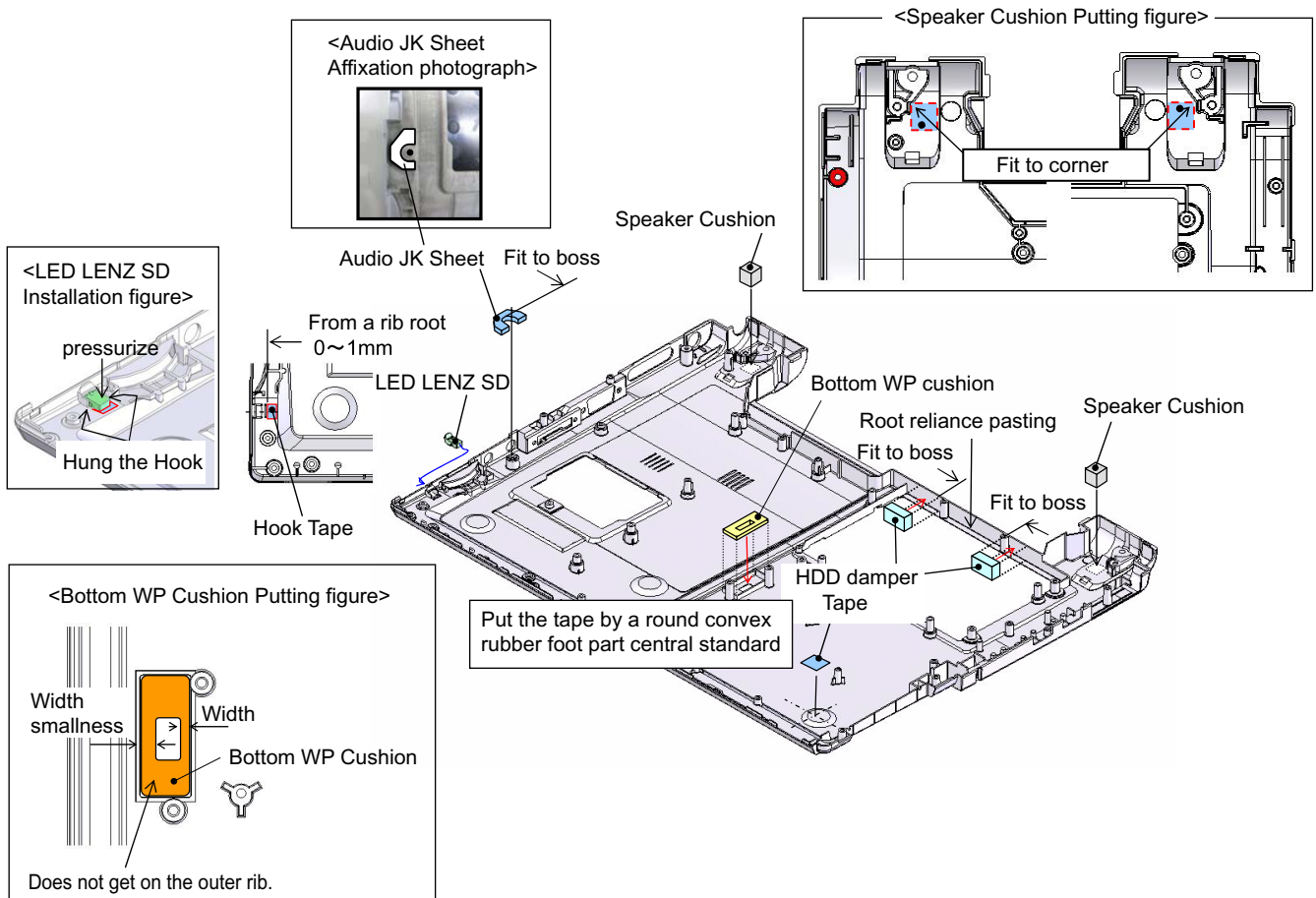
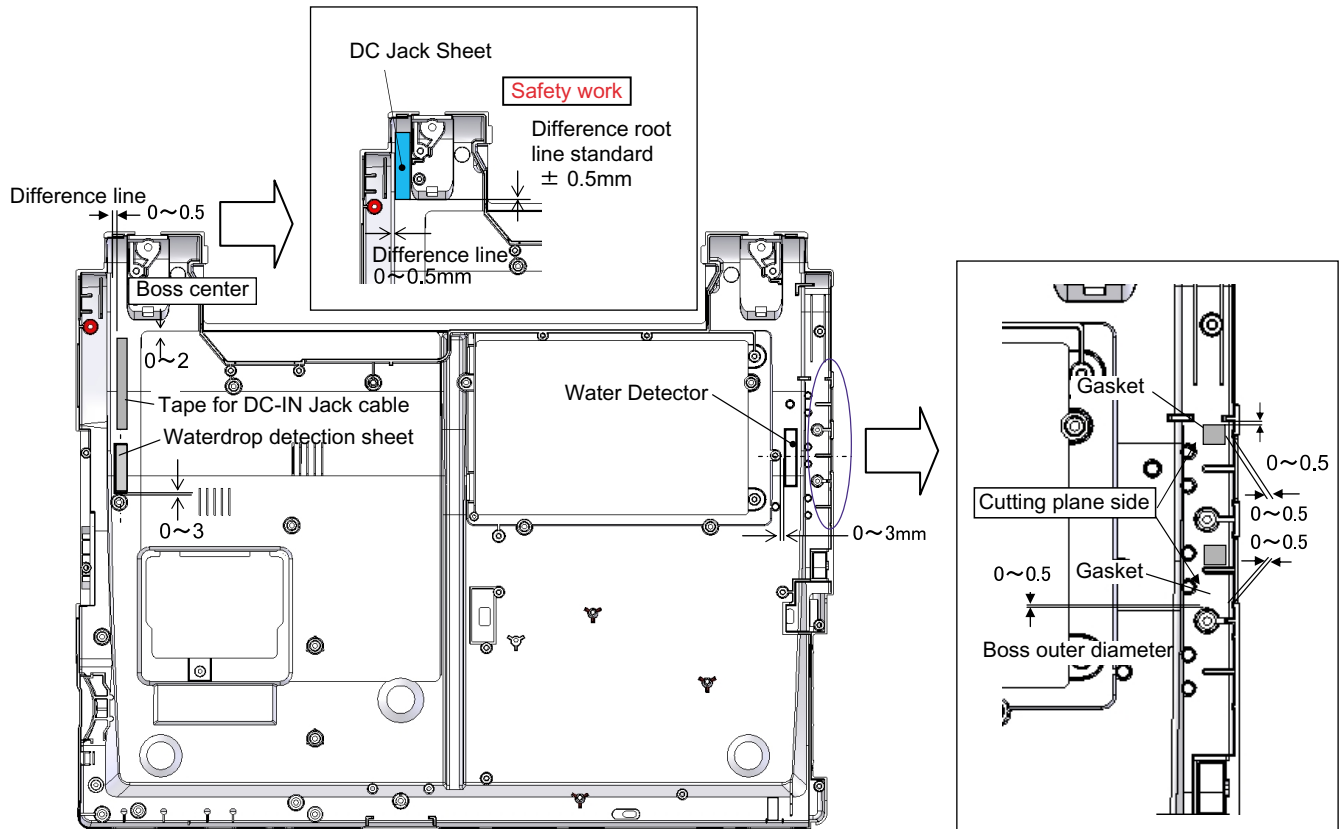

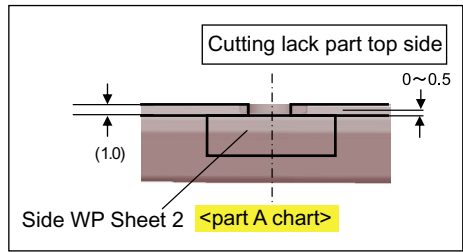

Safety Work

Cutting lack part central distribution pasting

A

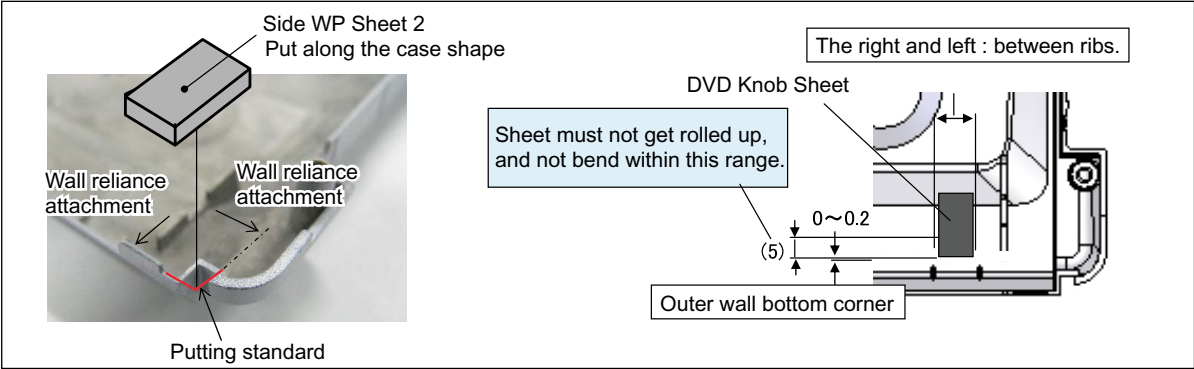
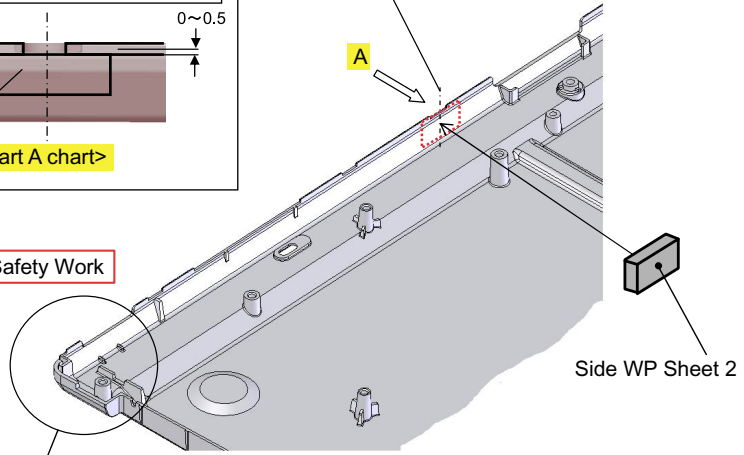

### 9.3.5.4. Putting Foot Rubber

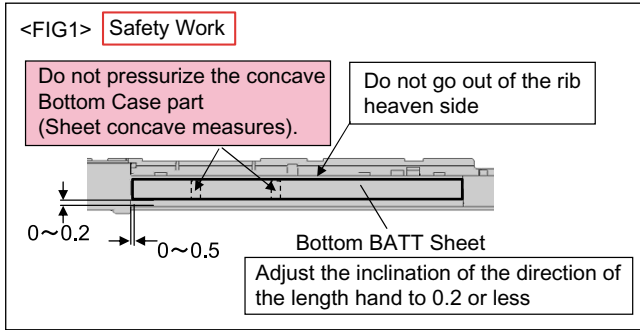

<Notes and procedures when rubber foot / rubber foot (center) putting>

- 1) Wipe rubber foot/ rubber foot (center) pasting side with the dry cloth (3 places)  
(Cautions) - Exchange the cloth (rag) wiped off regularly (twice / day)
- 2) A rubber foot/rubber foot(center) pasting  
(Cautions) - Put on the Bottom Case with tweezers etc.  
- Paste so as not to touch the sticking side.
- 3) Pressurizing (treatment device use) condition:  
Pressurizing power : 2.5kgf or more,  
Time : 3 seconds or more

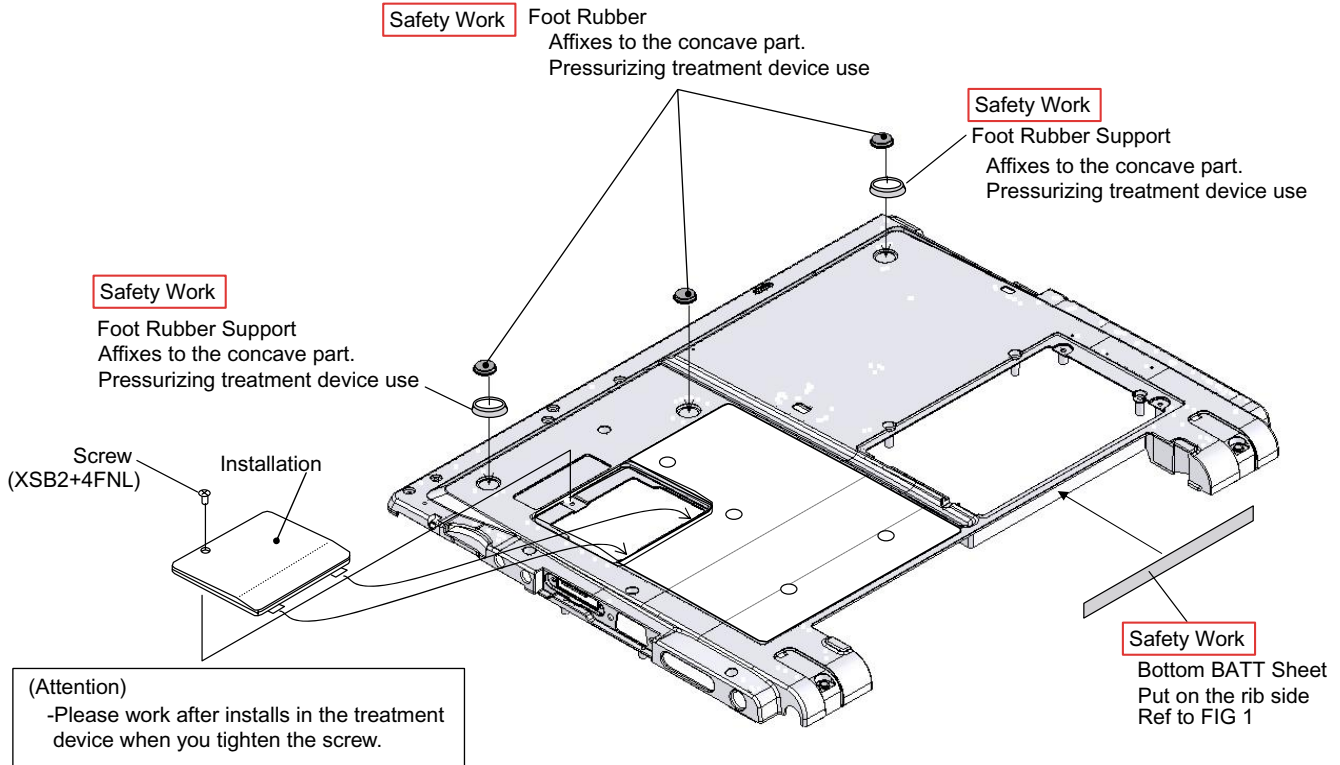

Work with a specified treatment device when you pressurize Foot Rubber and Bottom BATT Sheet .



### 9.3.6. Assembly knowhow of the Body

#### 9.3.6.1. Keyboard preparation

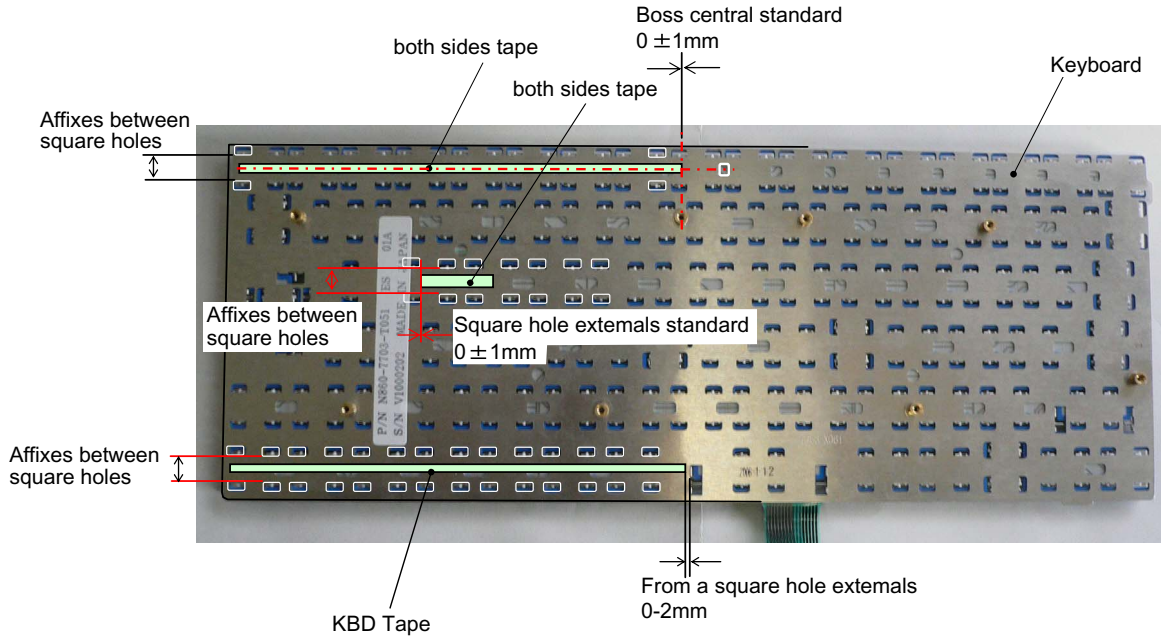

#### 9.3.6.2. Installation of Main Board

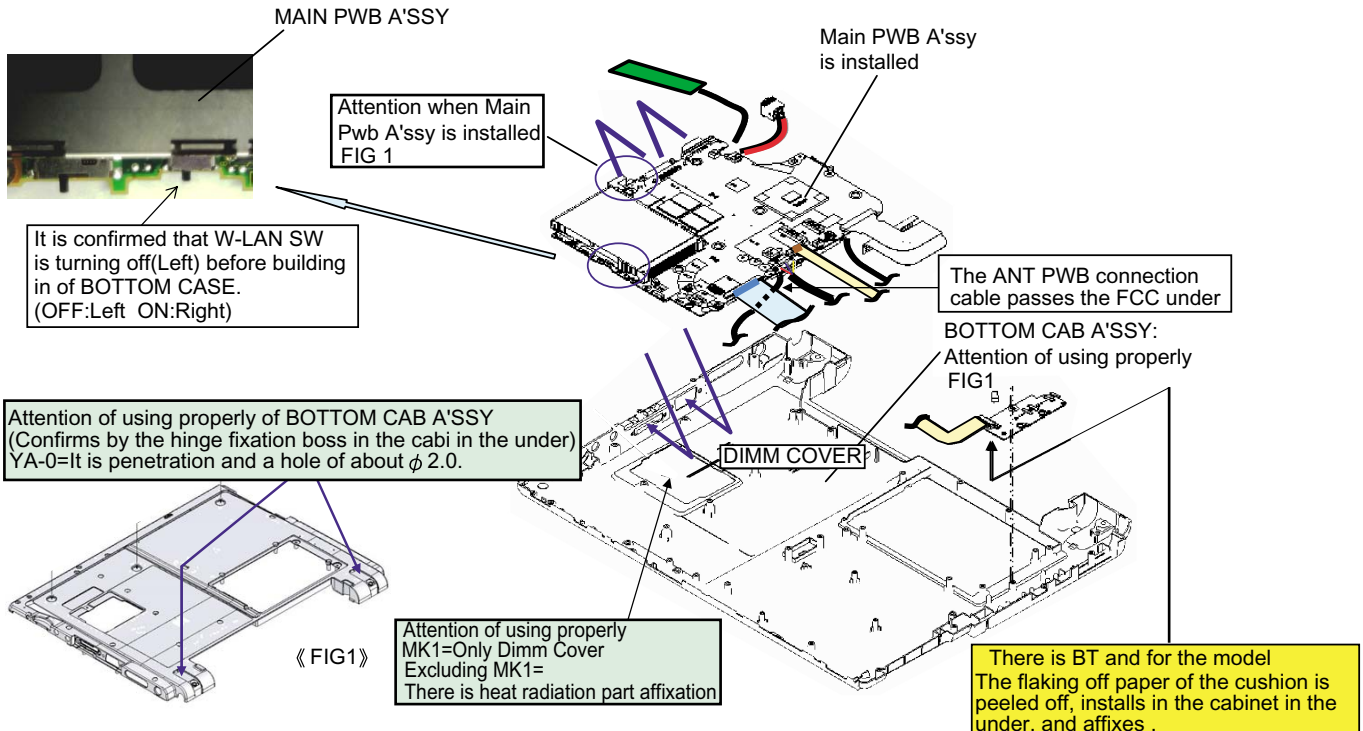

### 9.3.6.3. Assembly of the HDD Slot Guard

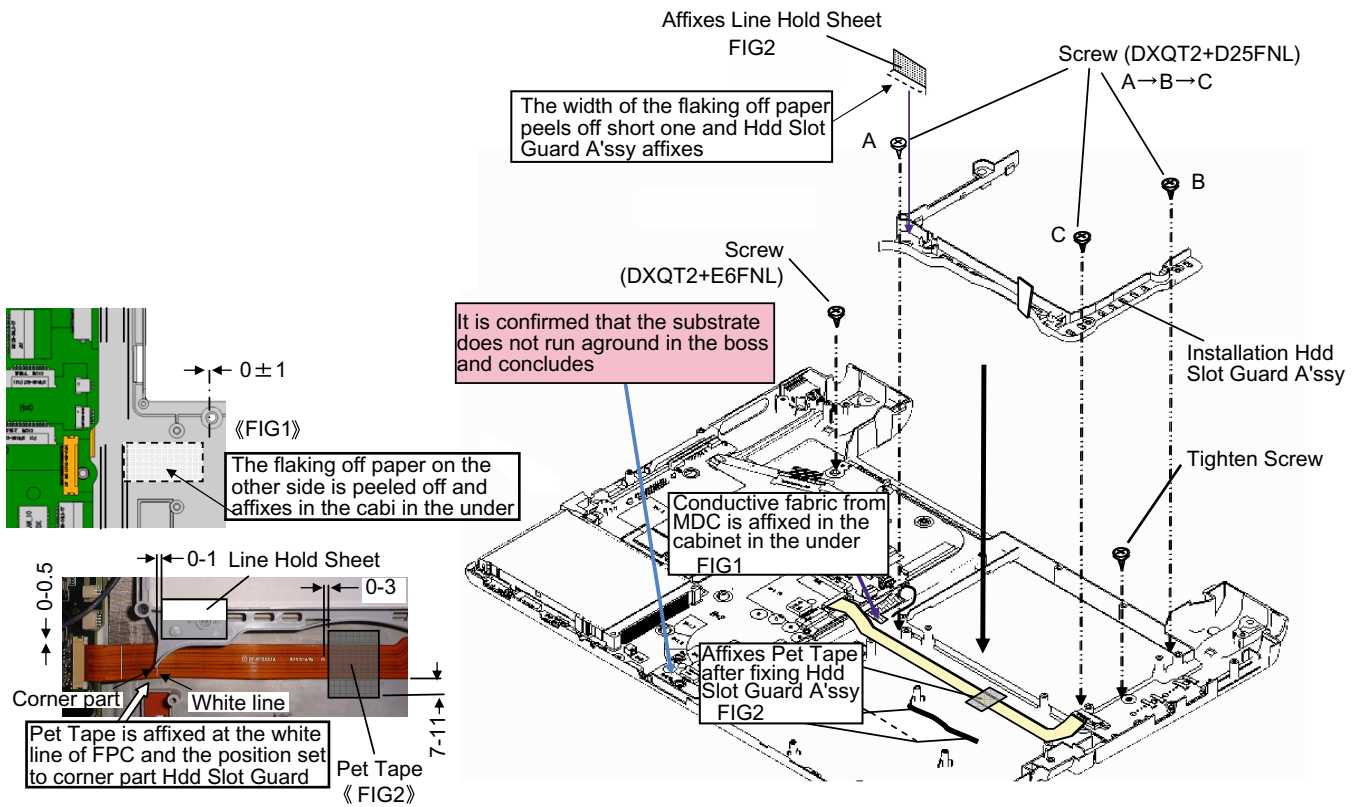



### 9.3.6.4. Putting Line Hold Sheet 3 / Line Hold Cushion

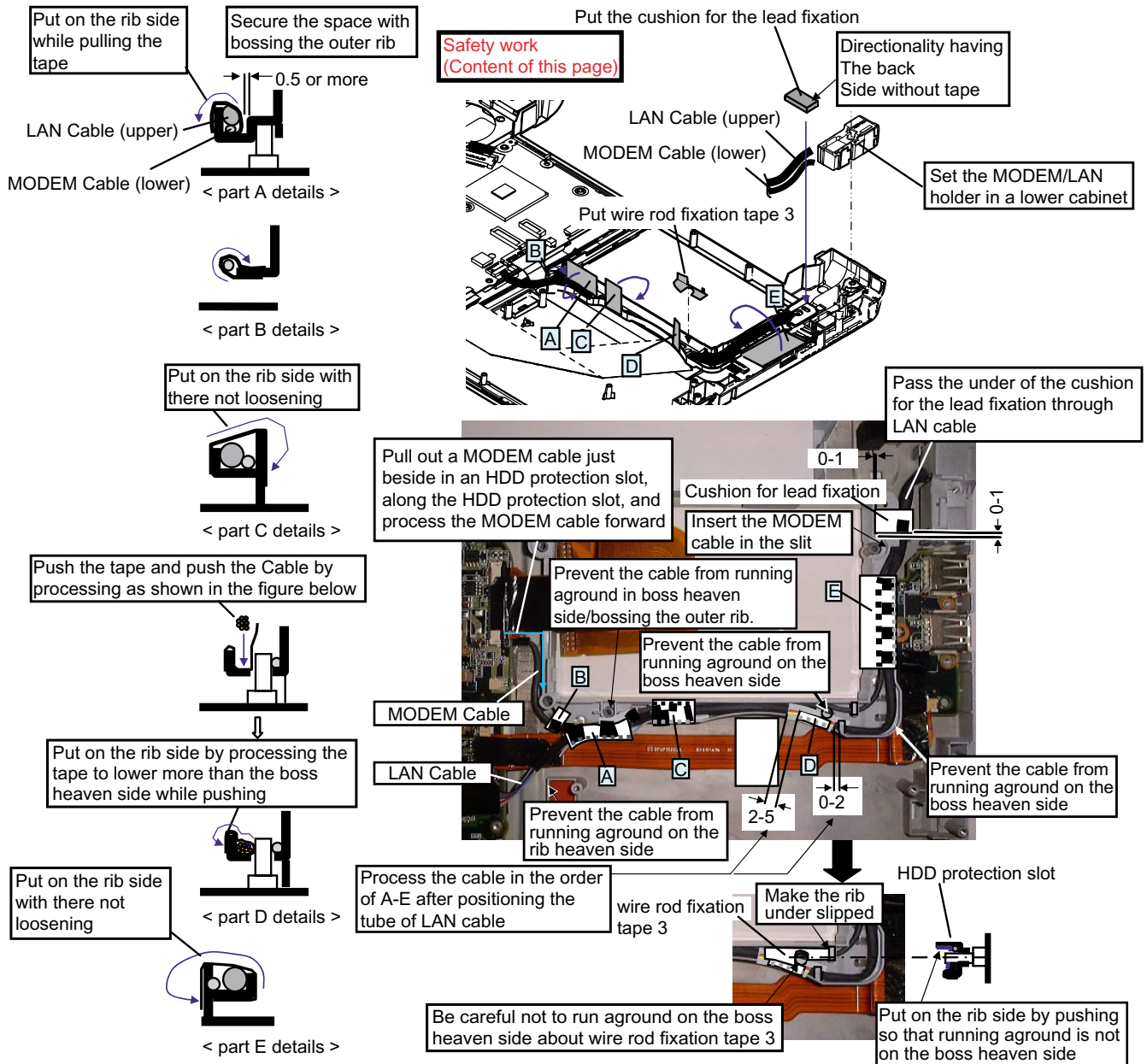

It is the same as last page excluding the undermentioned specification

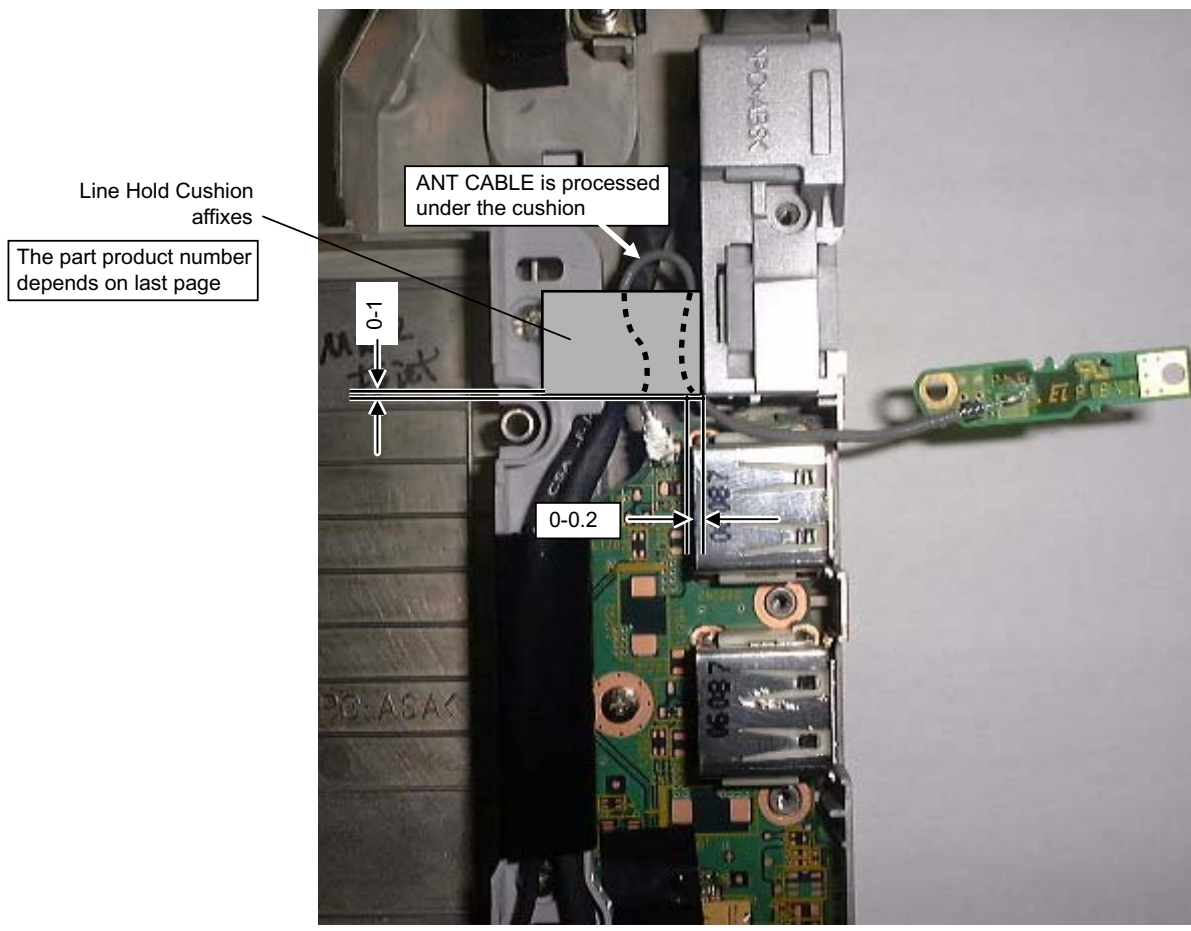

Line Hold Cushion affixes  
The part product number depends on last page

ANT CABLE is processed under the cushion

0-1

0-0.2

The Rib of Cabi in the under is passed and the concave part is passed

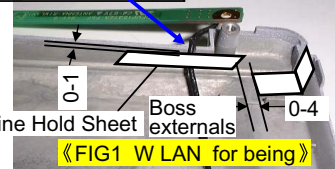

Line Hold Sheet is affixed with ANT PWB arranged at the figure below position

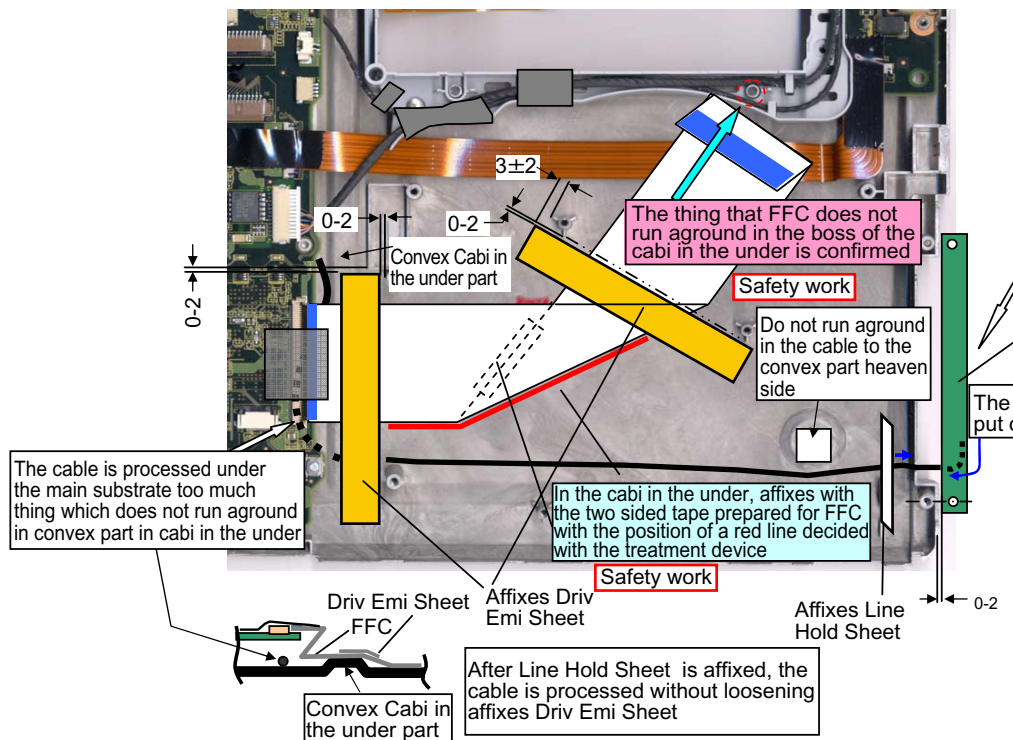

### 9.3.6.5. Installation of LCD Unit

**[Cautions]**  
 Cannot be repetition used because of use of a fixed type lock agent.  
 Exchange for a new article in the case of re-bolting.

The EMI sheet 3 removes a half exfoliation paper, and twists around a LCD cable, and one of the two sticks it on a bottom case.

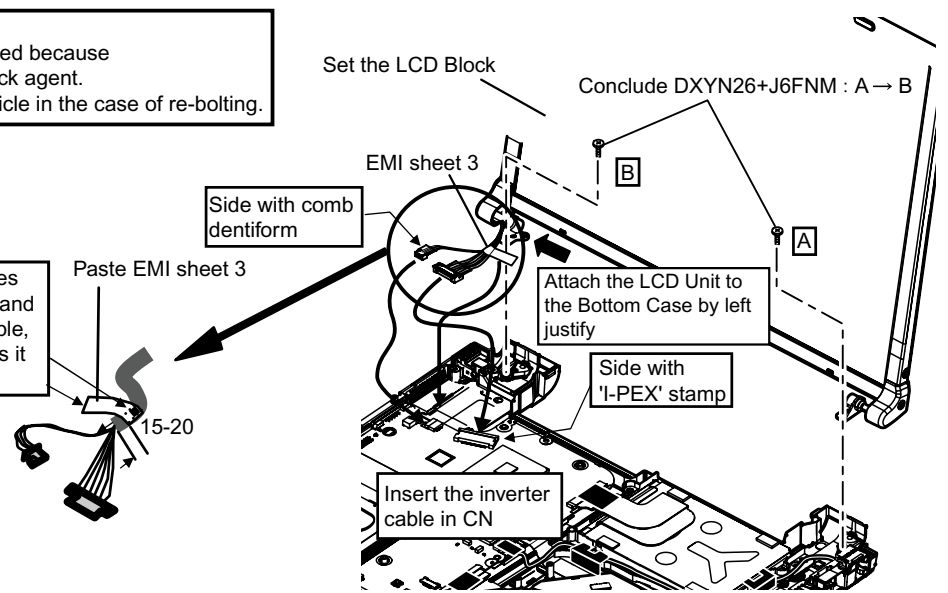

**Safety work**

Cable black tape externals 0-1

Bottom case rib side

On slope part of hinge metal fittings

Pass between cushions with the bottom case boss

Put Conductive Cloth with the black tape left end of the cable set to the bottom case side

Be along the root of the wall of the LCD Cable

Be careful not to cover this hole with the Conductive Cloth

Insert CN of the inverter cable and make the main substrate under slipped

Thing without Cable within  $\phi 8$  (Copper Foil =  $\phi 9$ )

Prevent the cable from being within  $\phi 8$  (Copper Foil =  $\phi 9$ )

The inverter cable is LCD cable back

### 9.3.6.6. Assembly of the DC Jack Plate

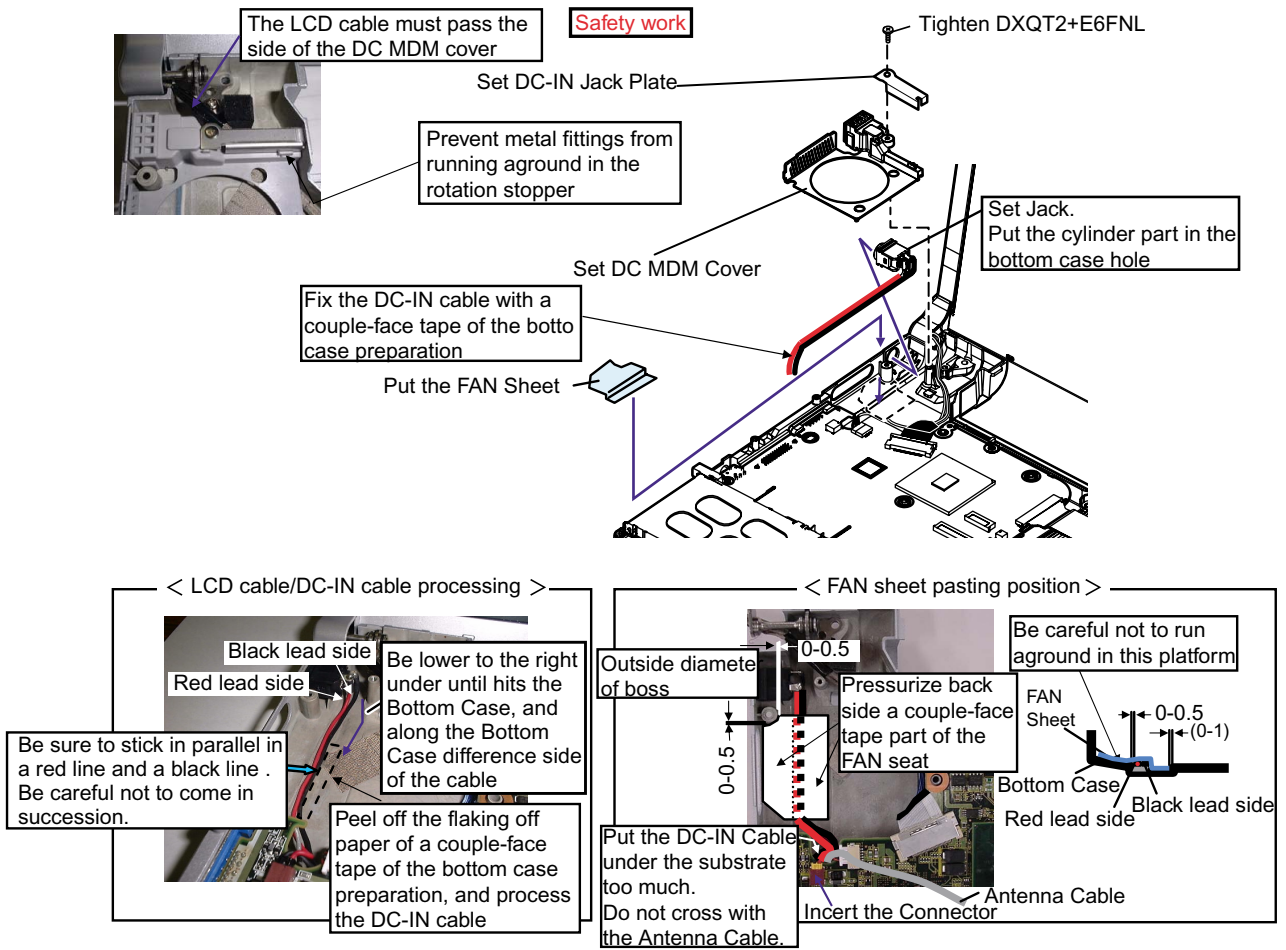

### 9.3.6.7. Putting Main PCB Sheet

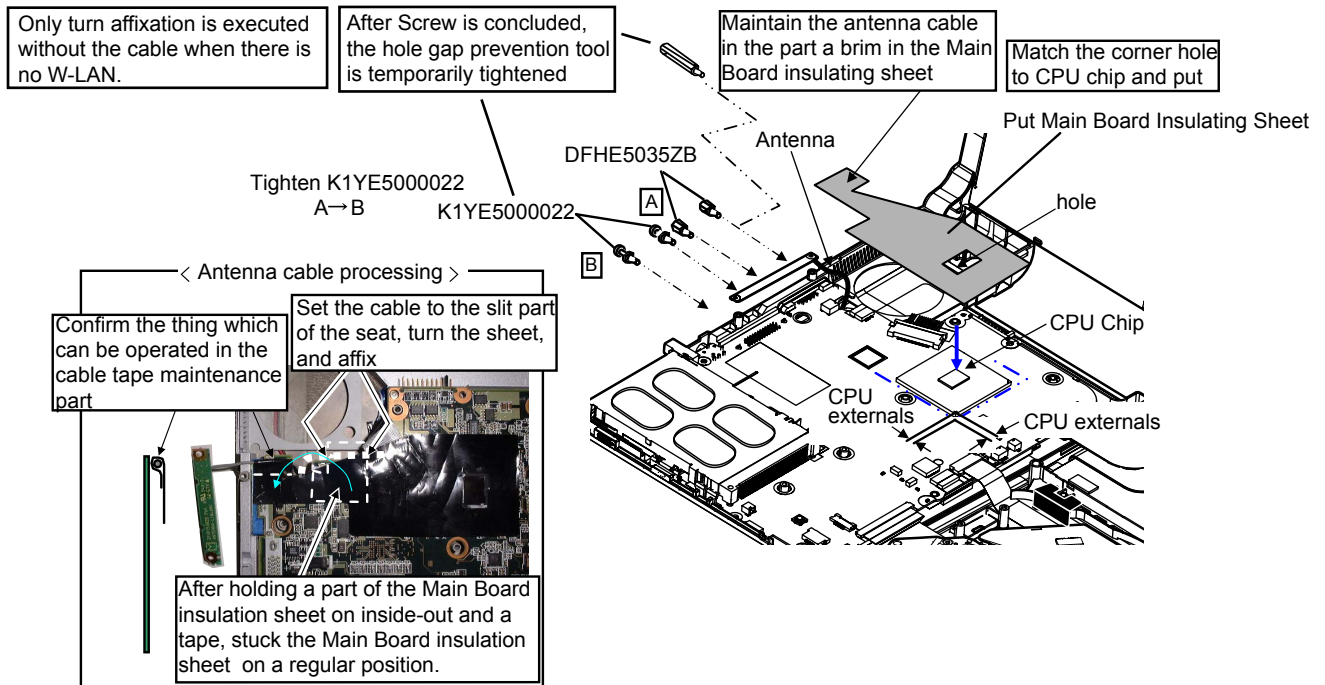



### 9.3.6.8. Assembly of the DVD Drive

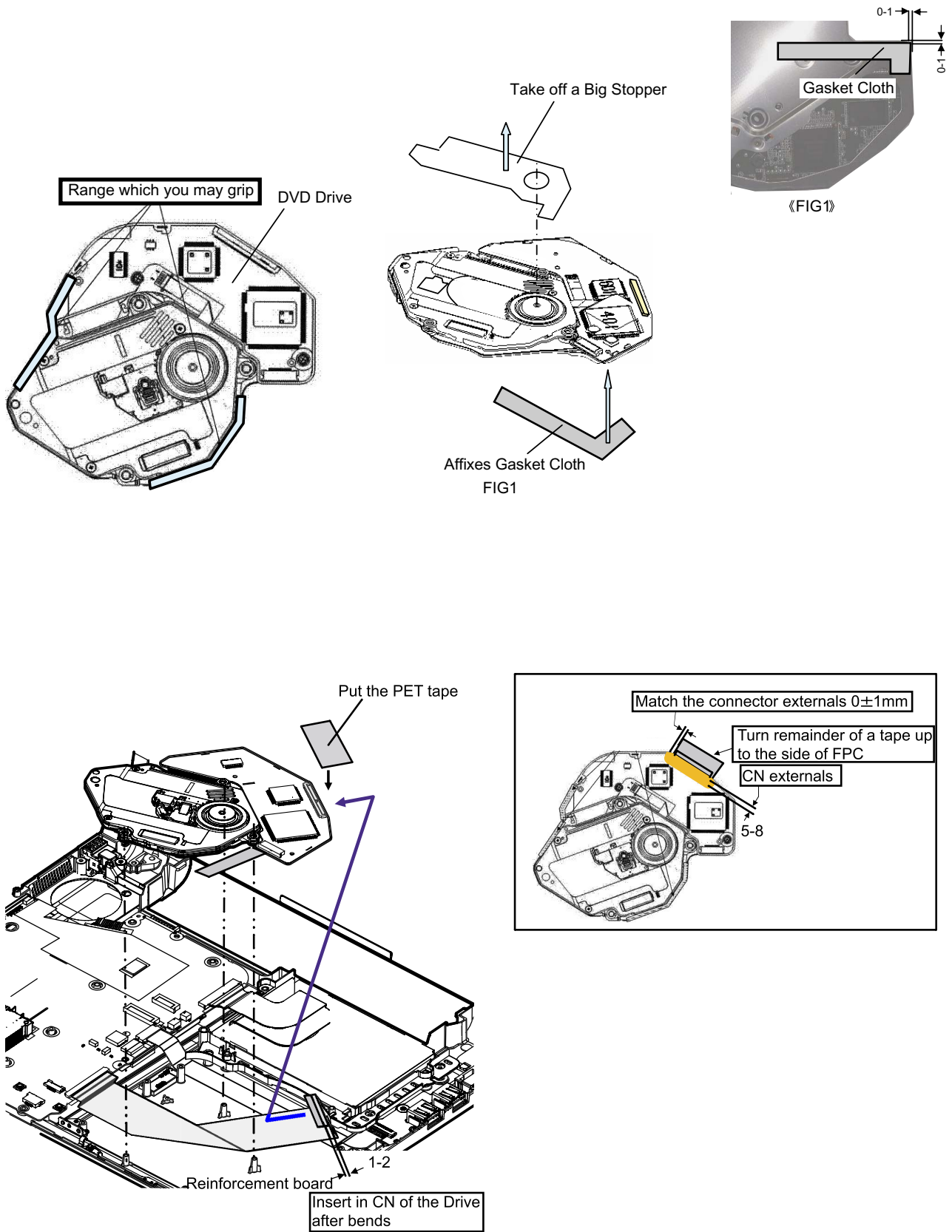

### 9.3.6.9. Installation of Power Knob / LAN SW Knob

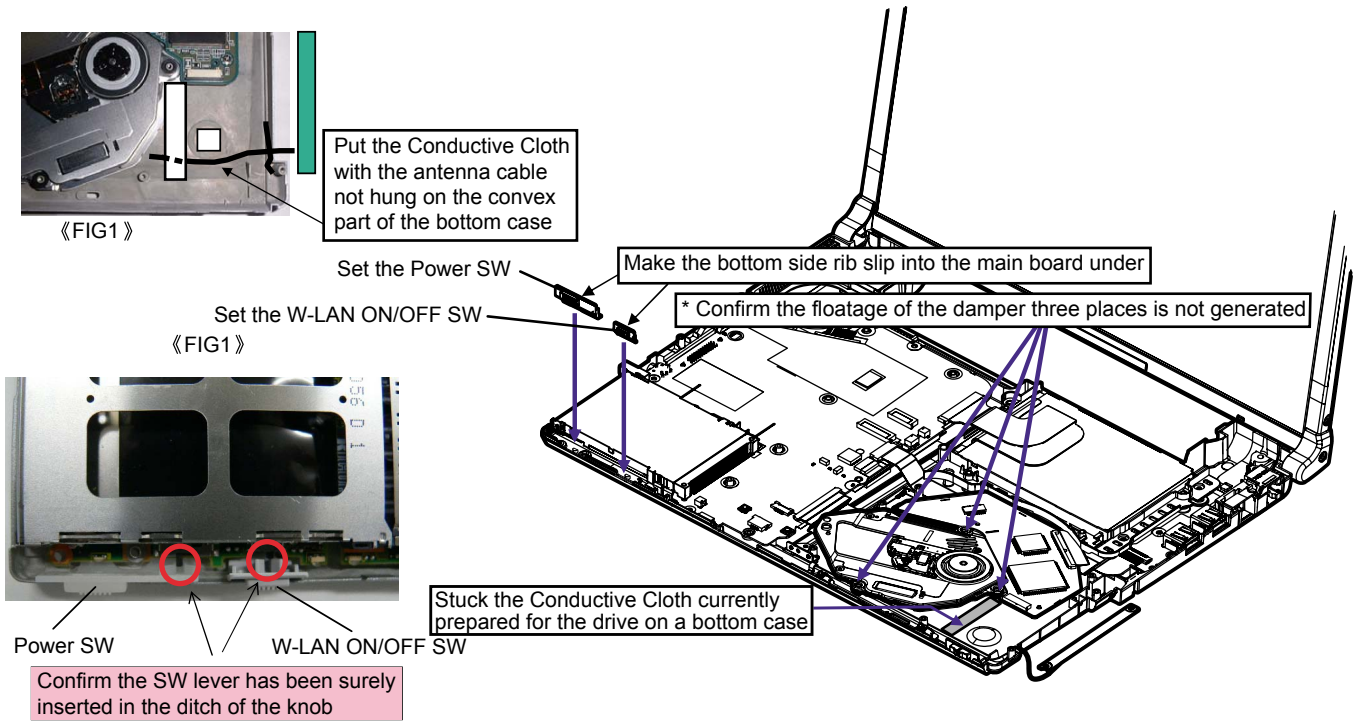

### 9.3.6.10. Assembly of the Body

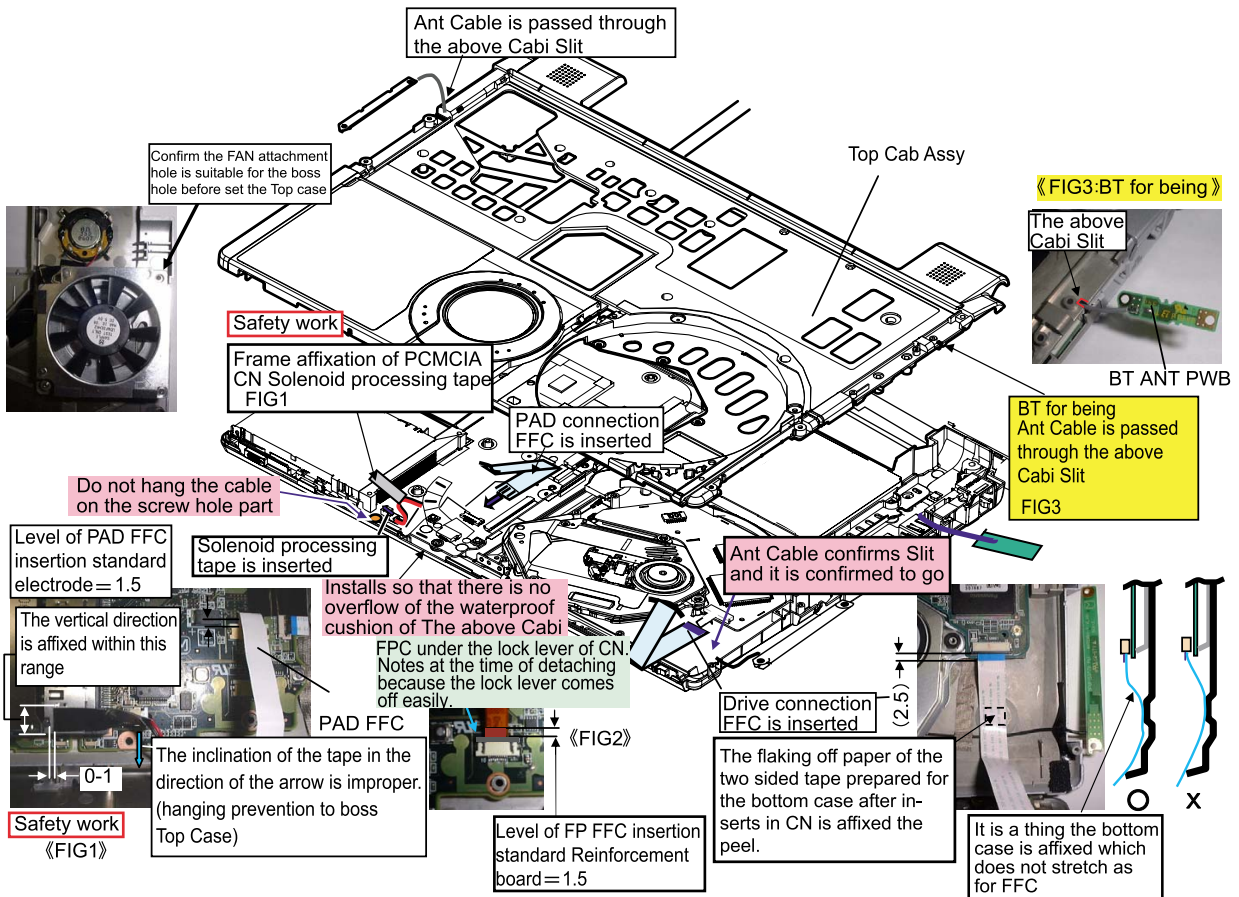

### 9.3.6.11. Top Case side screw tightening

① DXHM0056ZA  
 ② DXQT2+E6FNL  
 ⑤ DXQT2+F3FNL  
 ④ DXQT2+E10FNL  
 ③ DRQT2+E8FKL  
 ⑥ DXHM0056ZA

Engages with Board's concave part Top Case Rib

The tightening order = A → T  
 The following are prepermission

When there is BT

The cable is along bossing outer and processed. Do not go out of the above cabi side.

Disk Angle installation

<Processing of Antenna Cable >  
 Draws under the side of Board after tightening of the Screw and pushes into the inside too much

Cable is tightened and so as not to bite, the putting out Screw is tightened on the outside among Board and boss-es

<Processing of Antenna Cable >  
 Cable confirms the slit part and the going thing is confirmed

The externals overplus to which Cable does not go out of the Top Case side is processed under Board

### 9.3.6.12. Installation of K/B Heat Spreader

Heat radiation plate installation for CPU

To the range of the heat radiation board of the steps dropping part

Heat radiation board installation

To the hole part of a top case

Grease spreading on the other side with treatment device

HDD Seat putting

Thing without concave part range running aground of concave part and disk angle of top case, and thing without waving

Disk cover fixation seat putting

K/B Heat radiation seat putting

- Thing without concave part range running aground of top case, and thing without waving
- Peel off slowly when you peel off the flaking off paper. (Transformation and measures)

HDD seat putting: Flaking off paper three places

Thing without concave part range running aground of top case, and thing without waving

The flaking off paper of a two sided tape of the top case preparation is put and peel HDD seat is put.

<Heat radiation grease spreading position> (Heat radiation board)

13-15  
 3-5  
 9-11  
 6-8

Heat radiation grease(G-751) Spreading

<Heat radiation grease spreading position> (Heat radiation plate for CPU)

Heat radiation grease(G-751) Spreading

<Disk side cover fixation seat putting position >

0-0.5  
 0-0.5



### 9.3.6.13. Installation of Disk Cover / Disk Side Cover

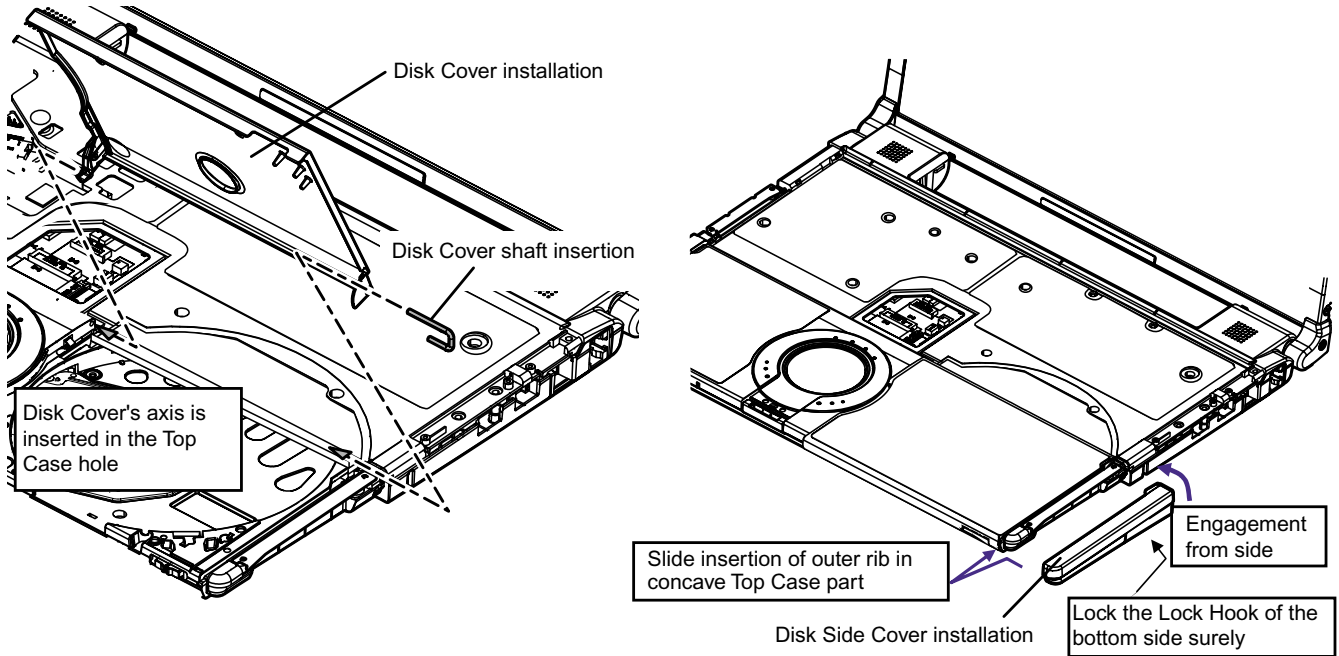

### 9.3.6.14. Installation of Keyboard

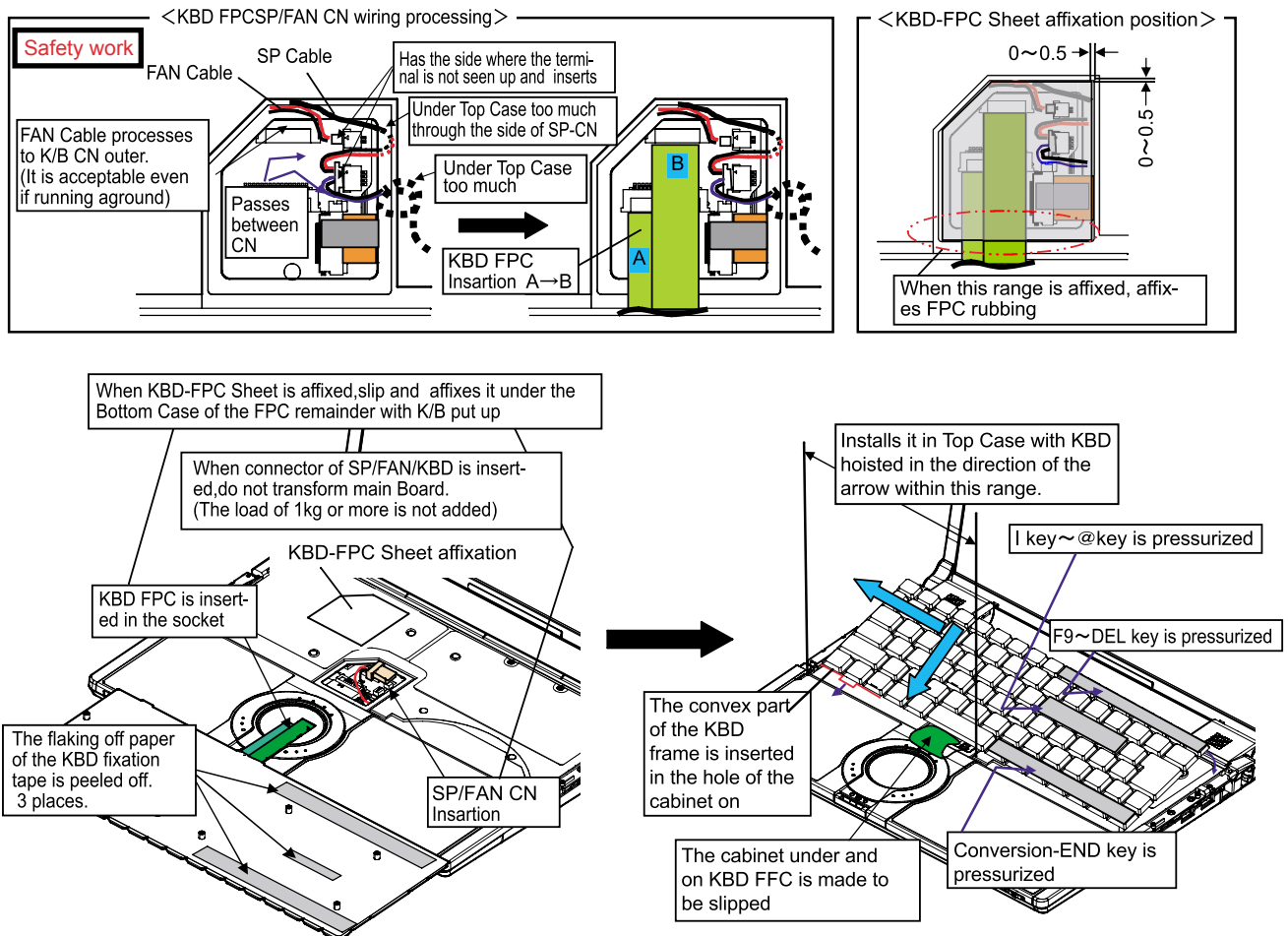

### 9.3.6.15. Installation of K/B Side Cover

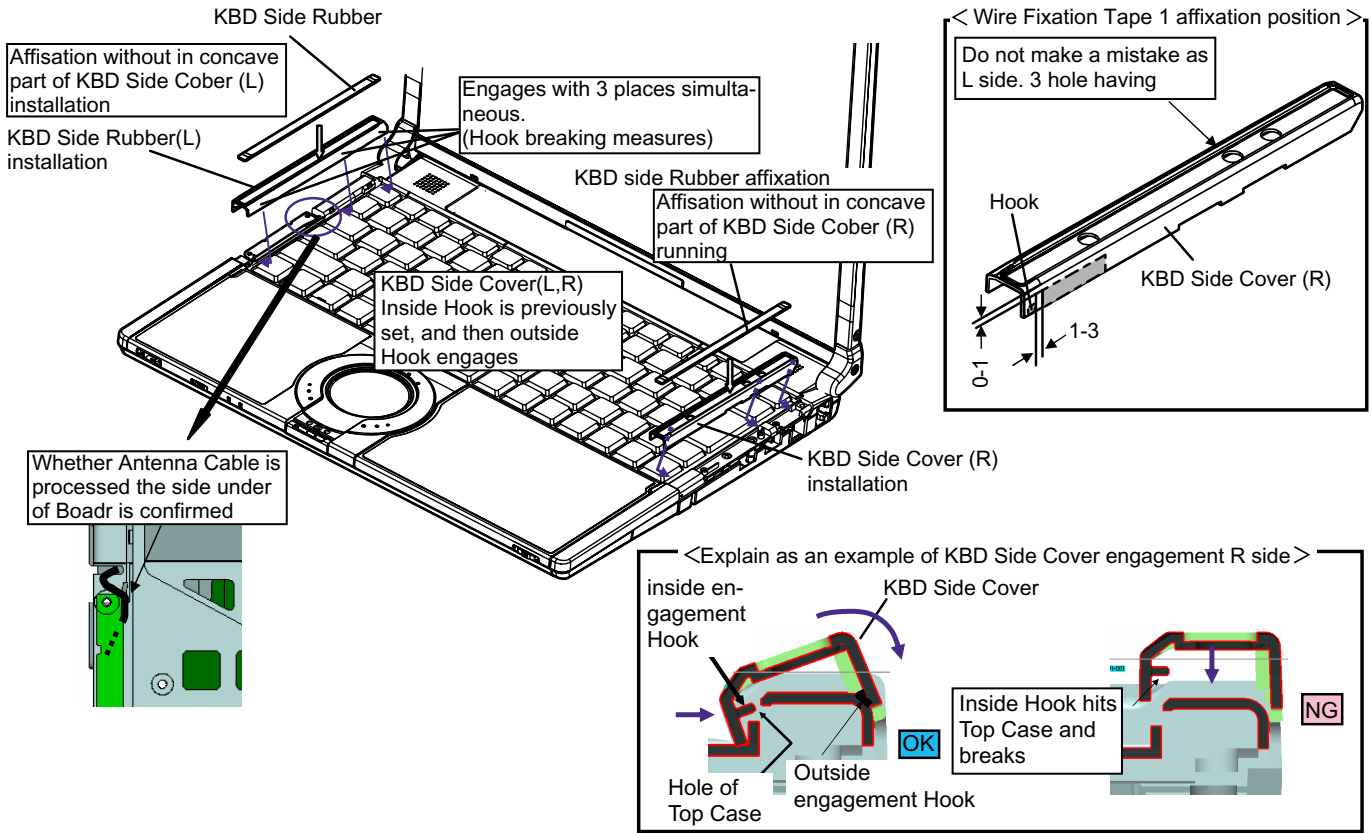

### 9.3.6.16. How to detach Keyboard and K/B Side Cover

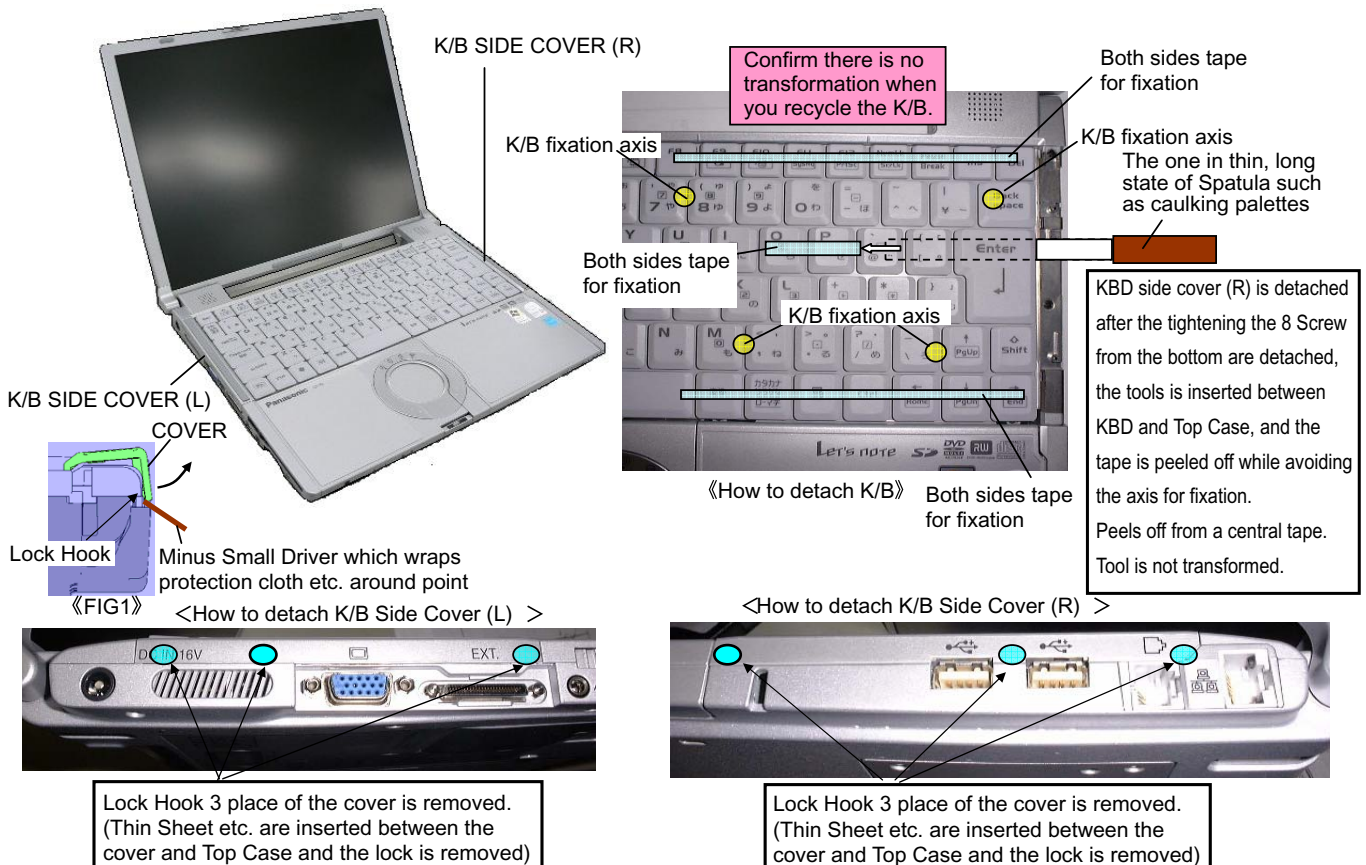

### 9.3.6.17. Installation of HDD

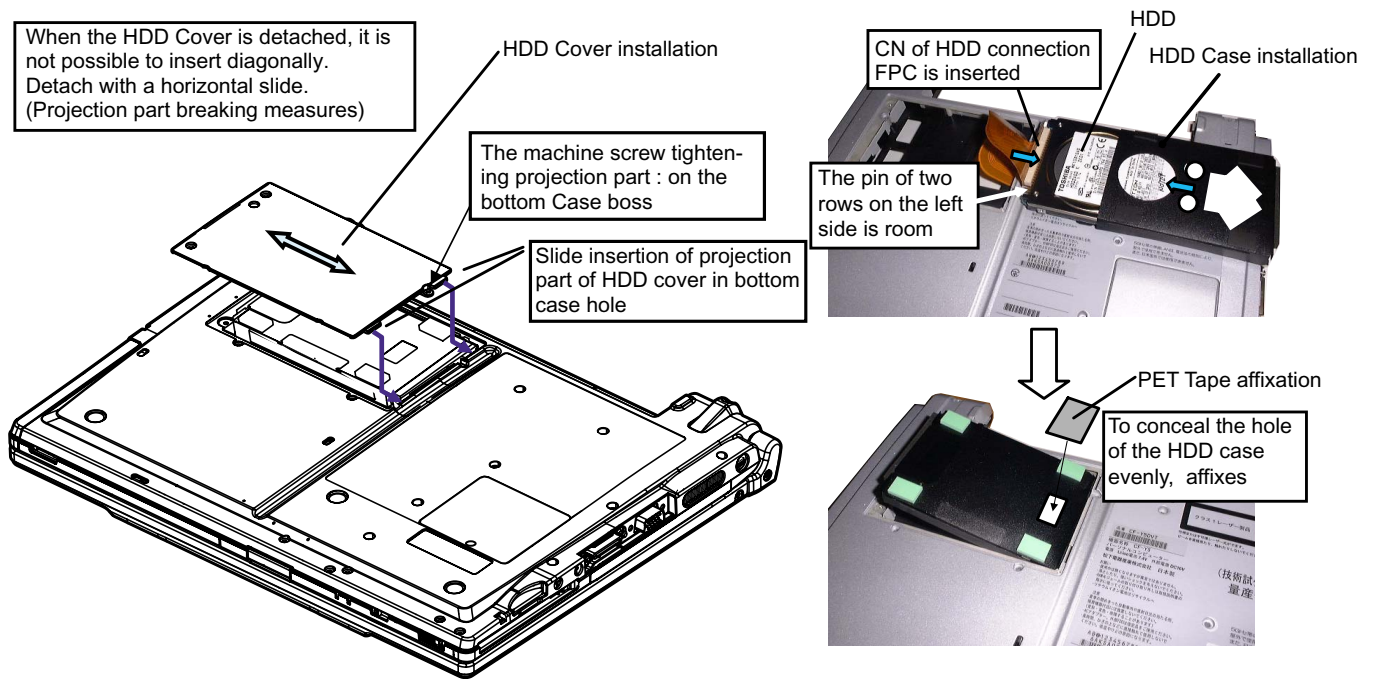

### 9.3.6.18. Bottom Case side screw tightening

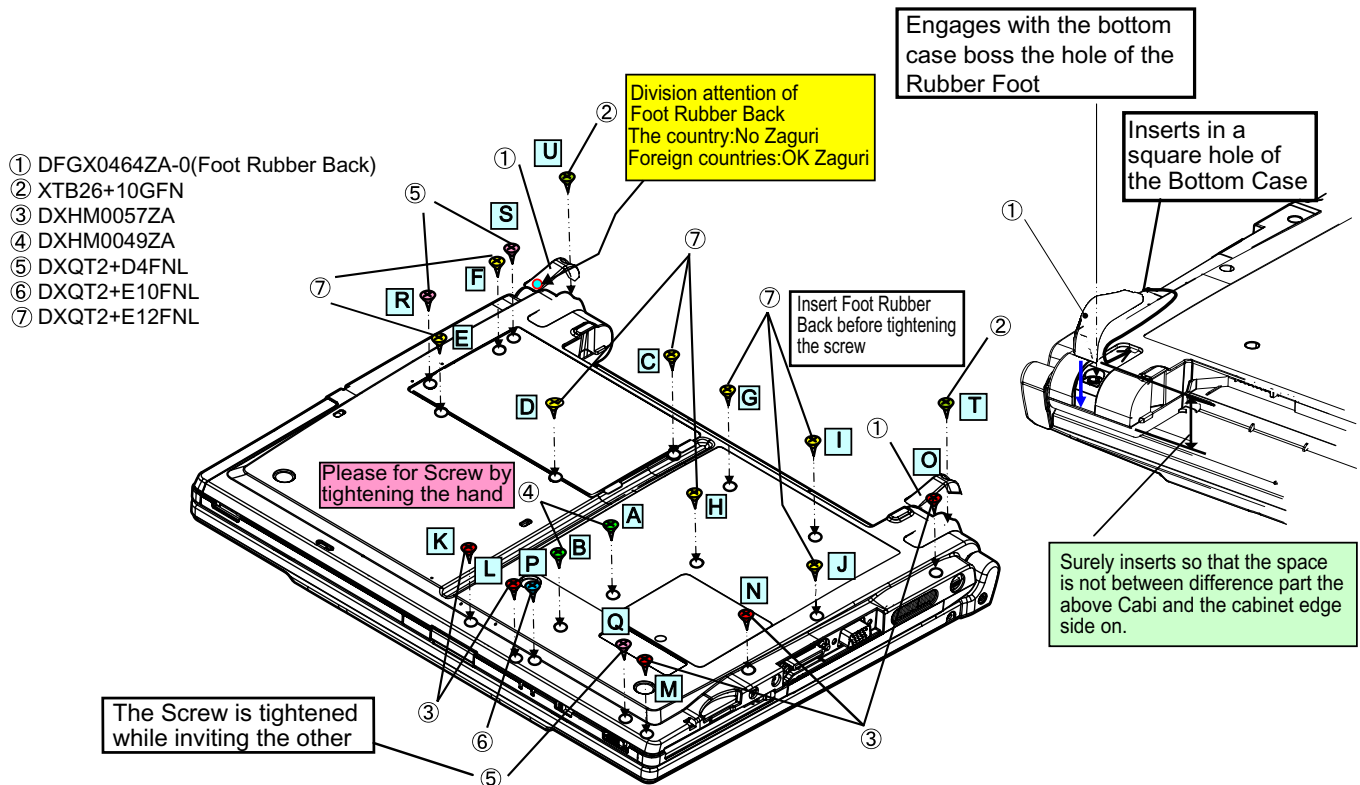

### 9.3.6.19. Putting Label

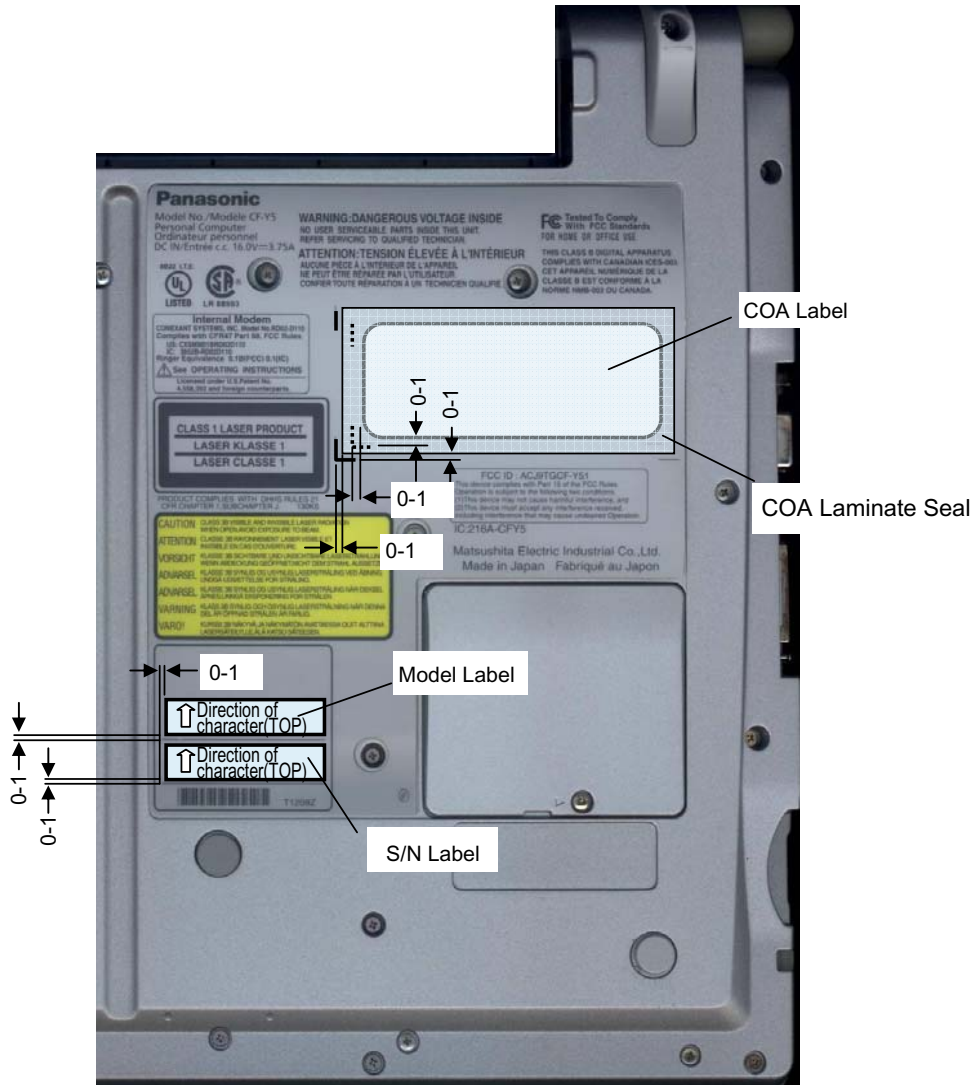

<Reference>  
DFQT0046ZA

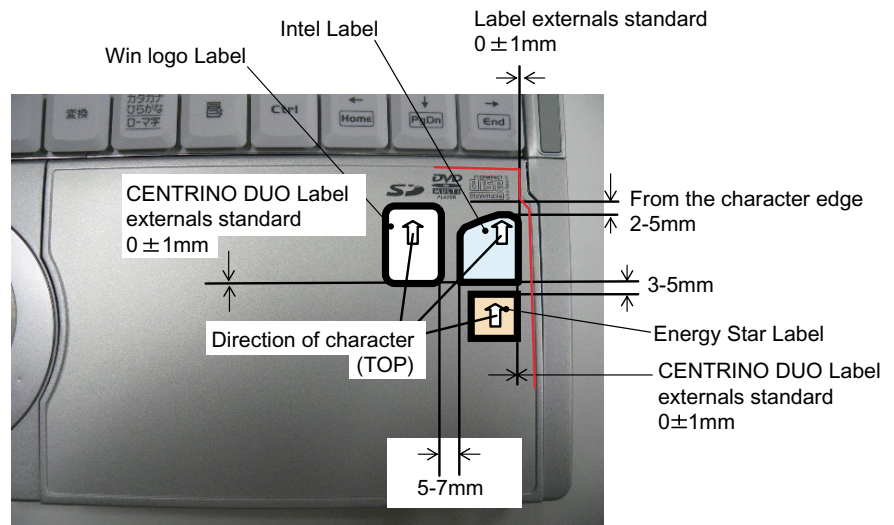
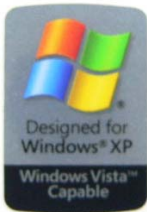



# 10 Exploded View

## 10.1. Display Section

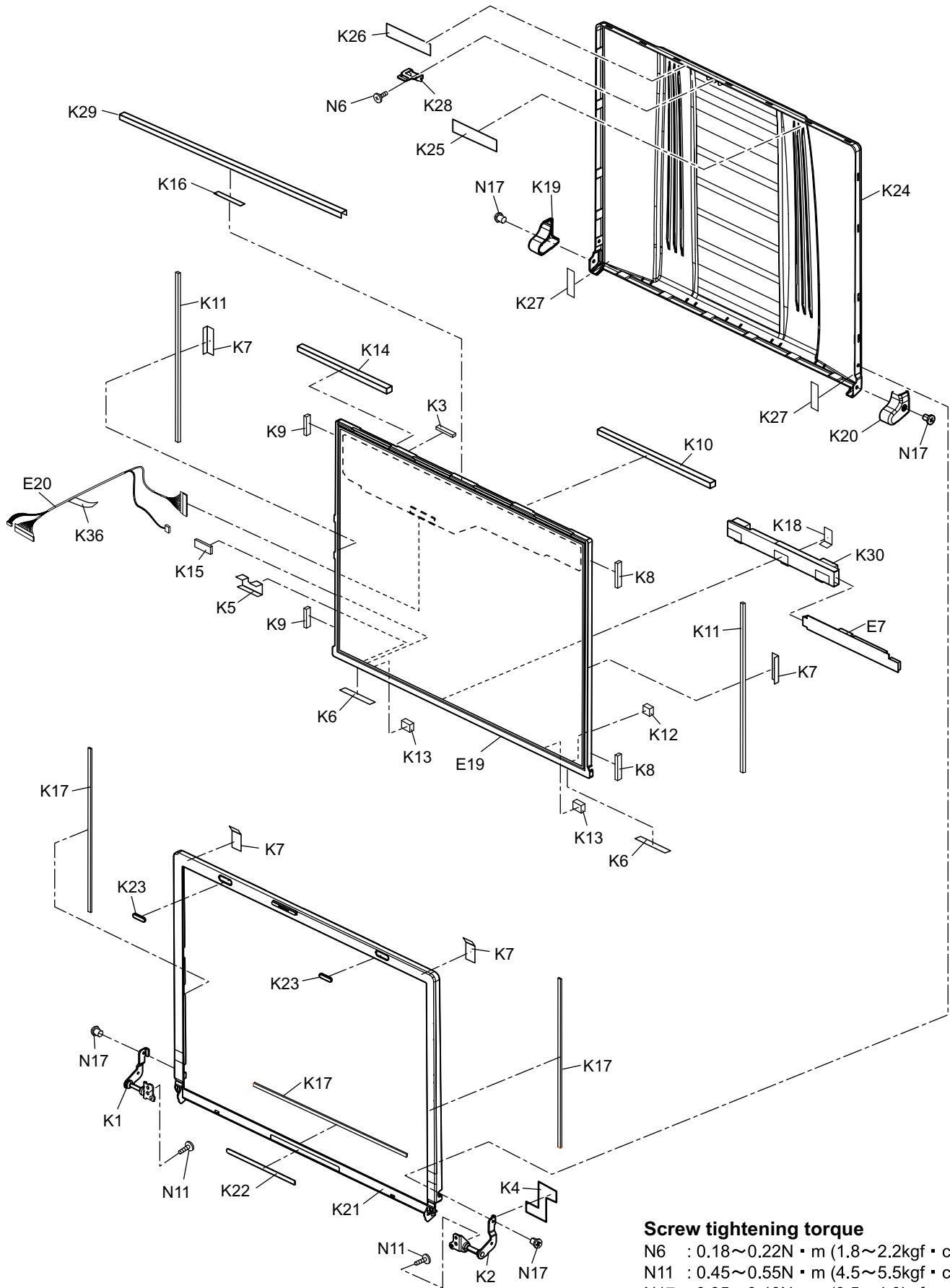

**Screw tightening torque**

N6	: 0.18~0.22N · m (1.8~2.2kgf · cm)
N11	: 0.45~0.55N · m (4.5~5.5kgf · cm)
N17	: 0.35~0.40N · m (3.5~4.0kgf · cm)

# 10.2. Cabinet Section

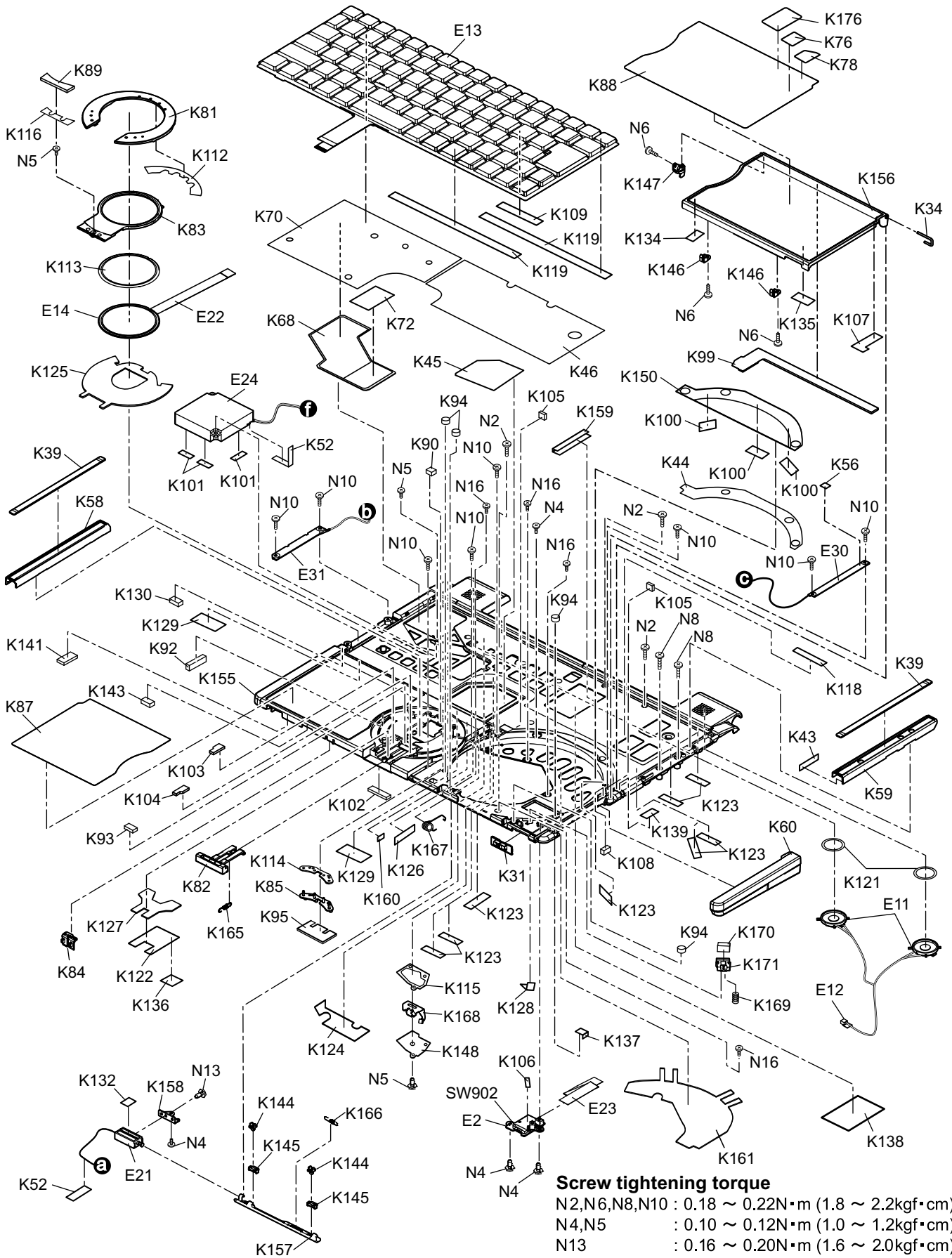

**Screw tightening torque**

N2, N6, N8, N10	: 0.18 ~ 0.22N·m (1.8 ~ 2.2kgf·cm)
N4, N5	: 0.10 ~ 0.12N·m (1.0 ~ 1.2kgf·cm)
N13	: 0.16 ~ 0.20N·m (1.6 ~ 2.0kgf·cm)
N16	: 0.11 ~ 0.15N·m (1.1 ~ 1.5kgf·cm)

# 10.3. Bottom Section

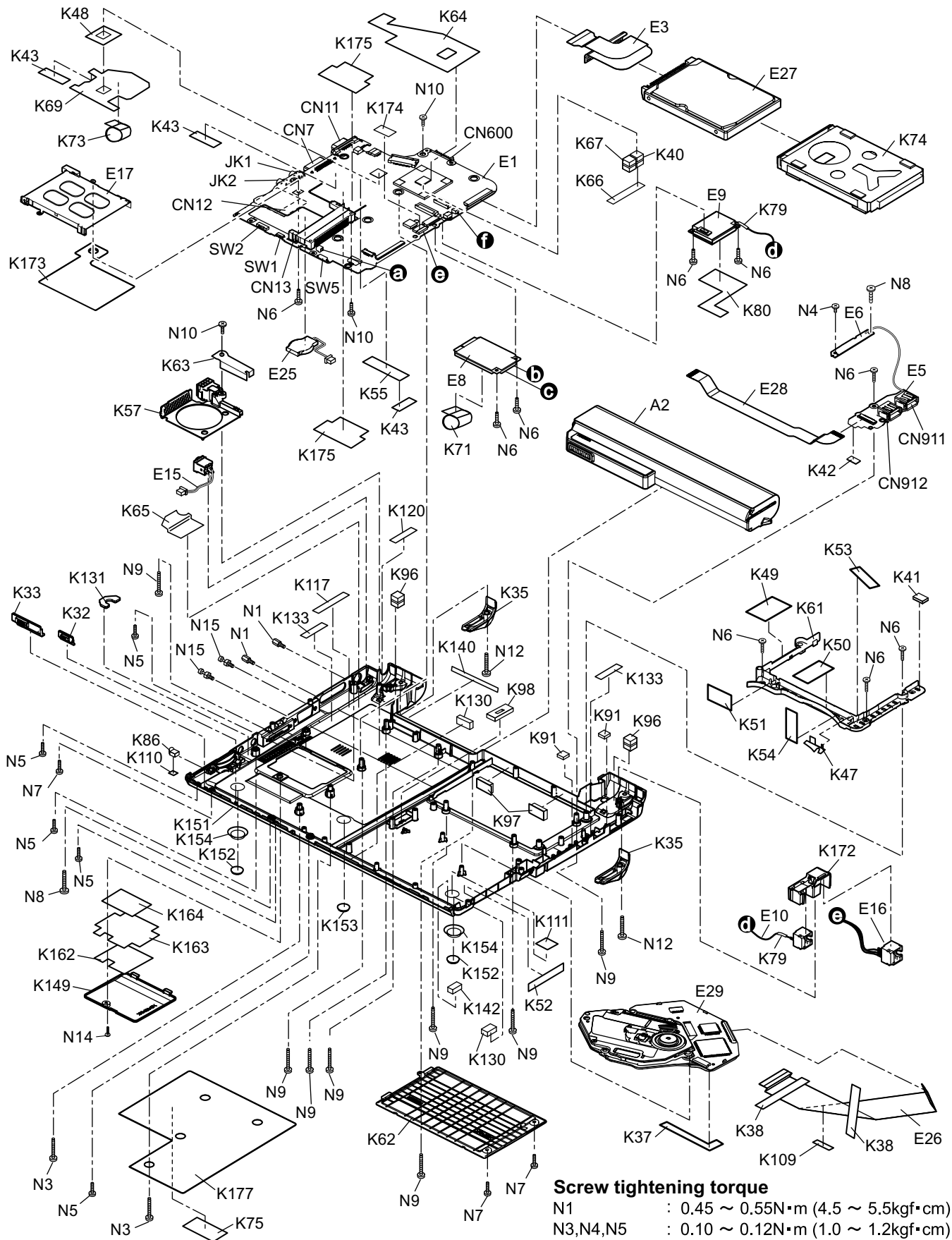

### Screw tightening torque

N1	: 0.45 ~ 0.55N·m (4.5 ~ 5.5kgf·cm)
N3,N4,N5	: 0.10 ~ 0.12N·m (1.0 ~ 1.2kgf·cm)
N6,N7,N8,N9	: 0.18 ~ 0.22N·m (1.8 ~ 2.2kgf·cm)
N10,N14, N15	: 0.40 ~ 0.50N·m (4.0 ~ 5.0kgf·cm)
N12	: 0.40 ~ 0.50N·m (4.0 ~ 5.0kgf·cm)





# 11 Replacement Parts List

**Note : Important Safety Notice**

Components identified by  mark have special characteristics important for safety. When replacing any of these components, use only manufacturer's specified parts.

**CF-Y5LWVYZBM**

REF. NO and AREA	PART NO.	DESCRIPTION	Q'TY
<b>Main Block Unit</b>			
E1	DL3U11528ABA	PCB, MAIN	RTL 1
E2	DL3U31528ABA	PCB, SUB DVD	RTL 1
E3	DL3UP1521AAA	HDD FPC UNIT	1
E5	DL3UP1581BBA	BLUETOOTH-USB PCB UNIT(WITH BT)	RTL 1
E6	DL3UP1585BBA	BLUETOOTH ANTENNA PCB UNIT	RTL 1
E7	 N0GF1J000008	INVERTER	1
E8	 N5HZC0000019	WIRELESS LAN MODULE	1
E9	 N5HAZ0000014	MODEM	1
E10	DFJS1024ZA	MODEM CABLE	1
E11	L0AA20A00007	SPEAKER	2
E12	DFJS1023ZA	SPEAKER CABLE	1
E13	N2AZZY000019	KBD (US)	1
E14	N2EAYYY00008	TOUCH PAD	1
E15	 DFJS1022YA	DC-IN CABLE	1
E16	DFJS1025ZA	LAN CABLE	1
E17	K1YYZZ000060	CONNECTOR	1
E19	L5EDDYY00038	LCD	1
E20	DFJS1021ZB	LCD CABLE	1
E21	L9AAAYYB0004	SOLENOID	1
E22	DFJK12U112BB	FFC, PAD	1
E23	DFJK20T108BB	FFC, SW PCB	1
E24	UDQFSEH62	FAN	1
E25	CR-2032/K5B	COIN BATTERY	1
E26	DFJK9022ZA	FFC, DRIVE	1
E27	 N3CAYYY00006	HDD	1
E28	DFUP1522YA	FPC, USB	1
E29	UJ-833ECD2-Z	DVD MULTI DRIVE	1
E30	DL3UP1537AAA	ANTENNA PCB UNIT R	RTL 1
E31	DL3UP1538AAA	ANTENNA PCB UNIT L	RTL 1
<b>Accessories</b>			
A1	 DFQX5647ZA	MANUAL(CF-Y5MK1)	1
A2	 NCR-B/601A	LITHIUM ION BATTERY PACK	1
A3	 CF-AA1633AM1	AC ADAPTOR	1
A4	 K2CG3DR00003	AC CORD	1
A5	DFJS1070ZA	MODEM CABLE	1
<b>Packing Material</b>			
P1	DFPE0772ZA	ACCESSORIES BOX	1
P2	DFPE0842ZA	HOLDER	1
P3	DFPN0841ZA	CUSHION T	2
P4	DFPN0842ZA	CUSHION B	2
P5	DFPK1158RA	PACKING CASE	1
<b>Mechanical Parts</b>			
K1	DFBH3049ZA	HINGE L	1
K2	DFBH3050ZA	HINGE R	1
K3	DFHE0843ZA	LCD MAGNET	1

K4	DFHE0994ZA	GASKET CLOTH	1
K5	DFHE0998ZA	CABLE GASKET CLOTH	1
K6	DFHG1774ZA	LCD SIDE DAMPER	2
K7	DFHG1871ZA	LCD SIDE CUSHION 1	4
K8	DFHG1872ZA	LCD SIDE CUSHION 2	2
K9	DFHG1873ZA	LCD SIDE CUSHION 3	2
K10	DFHG1874YA	LCD CUSHION 1	1
K11	DFHG1875ZA	LCD CUSHION2	2
K12	DFHG1876ZA	LCD REAR CUSHION 1	1
K13	DFHG1877YA	LCD REAR CUSHION 2	2
K14	DFHG1911ZA	LCD CUSHION 3	1
K15	DFHG830ZA	CON SPACER	1
K16	DFHP7175ZA	LCD TAPE C	1
K17	DFHP7239ZA	LCD TAPE 1	3
K18	DFHR3E07ZA	INVERTER TAPE	1
K19	DFKE0835YA-0	HINGE COVER L	1
K20	DFKE0836YA-0	HINGE COVER R	1
K21	DFKF0269YA-0	LCD FRONT	1
K22	DFGX0397ZA-0	LCD BATT RUBBER	1
K23	DFHG1546ZB-0	LCD RUBBER	2
K24	DFKM0510ZA-0	LCD REAR	1
K25	DFHR3E08ZA	LCD REAR TAPE 1	1
K26	DFHR3E09ZA	LCD REAR TAPE 2	1
K27	DFHR3E37ZA	LCD REAR TAPE 3	2
K28	DFMD1198VA	LCD HOOK	1
K29	DFMD2162ZA	LCD PROTECT PLATE	1
K30	DFMX1231YA	INVERTER BOX	1
K31	DFBD9009ZA-0	DISK EJECT KNOB ASSY 2	1
K32	DFBD0182ZA-0	LAN SW KNOB	1
K33	DFBD0189ZA-0	POWER KNOB	1
K34	DFDF5023ZA	DISK COVER SHAFT	1
K35	DFGX0464ZA-0	FOOT RUBBER BACK OS	2
K36	DFHE0463ZA	EMI SHEET 3	1
K37	DFHE0957ZA	GASKET CLOTH	1
K38	DFHE1003ZA	DRIVE EMI SHEET	2
K39	DFHG1858ZA-0	KB SIDE RUBBER	2
K40	DFHG1869ZA	CPU CUSHION	1
K41	DFHG1908ZA	LINE HOLD CUSHION	1
K42	DFHG1957ZA	BT PWB CUSHION 1	1
K43	DFHR3D21ZB	LINE HOLD SHEET 1	4
K44	DFHR3D23ZA	DISK ANGLE WP SHEET	1
K45	DFHR3D24ZA	KBD FPC WP SHEET	1
K46	DFHR3D25ZA	HDD WP SHEET	1
K47	DFHR3D59YA	LINE HOLD SHEET 3	1
K48	DFHR3D60ZA	MCH SHEET	1
K49	DFHR3D75ZA	LINE HOLD SHEET 4	1
K50	DFHR3D76ZA	LINE HOLD SHEET 5	1
K51	DFHR3D77ZA	LINE HOLD SHEET 6	1
K52	DFHR3D80ZA	FAN/SP CABLE FIX SHEET	3
K53	DFHR3D82ZA	LINE HOLD SHEET 7	1
K54	DFHR3D84ZA	LINE HOLD SHEET 9	1
K55	DFHR3E22ZA	ANTENNA CABLE PROTECT SHEET	1
K56	DFHR3E35ZA	DISK SIDE COVER FIX SHEET	1
K57	DFHR6230ZA	DC MDM COVER	1
K58	DFKE0837ZA-0	KB SIDE COVER-L	1
K59	DFKE0838ZA-0	KB SIDE COVER-R	1
K60	DFKE0839ZA-0	DISK SIDE COVER	1
K61	DFKE0840ZA	HDD SLOT GUARD	1
K62	DFKE0894ZA-0	HDD COVER OS	1

K63	DFMD1202ZA	DC JACK PLATE	1
K64	DFMX1228ZA	MAIN PWB SHEET	1
K65	DFMY0428ZA	FAN SHEET	1
K66	DFMY0430ZA	CPU THERMAL TAPE	1
K67	DFMY0431ZA	CPU THERMAL SHEET	1
K68	DFMY3221ZA	HEAT SPREADER	1
K69	DFMY3222ZA	HEAT SPREADER BOTTOM	1
K70	DFMY3223ZA	KB HEAT SPREADER	1
K71	DFMY3224ZA	WLAN SHEET	1
K72	DFMY3227ZA	CPU THERMAL PLATE	1
K73	DFMY3228ZA	MCH THERMAL PLATE	1
K74	DFHG1956ZA	HDD CASE Y5 OS	1
K75	DFQX3999XA	OVERLAMINATE-LARGE	1
K76	DFQT0045ZA	ENERGY STAR LABEL	1
K78	DFQT9981ZA	CENTRINO DUO LABEL	1
K79	DFHE0862ZA	FILM IMPEDOR	2
K80	DFHE1009ZA	MDC EMI SHEET	1
K81	DFBC0320ZB-0	PAD BUTTON	1
K82	DFBS0075YA-0	LCD KNOB 2	1
K83	DFGE0134YA-0	PAD COVER	1
K84	DFGL0137ZA-0	LED LENZ BATT	1
K85	DFGL0147ZA-0	LCD LENS PAD	1
K86	DFGL0149ZA-0	LED LENZ SD	1
K87	DFGX0449ZA-0	PALMREST SHEET L	1
K88	DFGX0450XA-0	PALMREST SHEET R(TOUCH MULTI)	1
K89	DFGX9026ZA-0	PAD RING TOP	1
K90	DFHE0993ZA	GASKET PAD	1
K91	DFHE1010ZA	USB GASKET	2
K92	DFHG1778ZA	PCMCIA STOPPER CUSHION	1
K93	DFHG1860ZA	LCD KNOB WP CUHSION	1
K94	DFHG1861ZA	DISK COVER CUSHION	4
K95	DFHG1862ZA	LED CUSHION	1
K96	DFHG1863ZA	SPEAKER CUSHION	2
K97	DFHG1865ZA	HDD DAMPER	2
K98	DFHG1866ZA	BOTTOM WP CUSHION	1
K99	DFHG1867ZA	DISK COVER WP CUSHION	1
K100	DFHG1868ZA	DISK ANGLE CUSHION	3
K101	DFHG1878ZA	FAN CUSHION	3
K102	DFHG1898ZA	FRONT WP CUSHION	1
K103	DFHG1899ZA	PAD BUTTON WP CUSHION L	1
K104	DFHG1900ZA	PAD BUTTON WP CUSHION R	1
K105	DFHG1909ZA	DISK ANGLE WP CUSHION	2
K106	DFHG1910ZA	DISK LEVER FIX CUSHION	1
K107	DFHG1912ZA	DISK COVER WP CUSHION SMALL	1
K108	DFHG1914ZA	DISK SIDE COVER WP SHEET	1
K109	DFHP7106YA	BOTH SLDES TAPE	2
K110	DFHP7187ZA	HOOK TAPE	1
K111	DFHP7200ZA	AHDESIVE TAPE	1
K112	DFHP7236ZA	PAD BUTTON TAPE	1
K113	DFHP7237ZA	PAD COVER TAPE	1
K114	DFHP7238ZA	PAD LENS TAPE	1
K115	DFHP7248ZA	WATER CAP TAPE	1
K116	DFHP7249ZA	PAD RING TOP TAPE	1
K117	DFHP7253ZA	DC JACK CABLE TAPE	1
K118	DFHP7254ZA	KBD FIX TAPE	1
K119	DFHP7255ZA	KBD TAPE	2
K120	DFHR3067ZA	DU CON SCREEN SHEET B	1
K121	DFHR3812YA	SPEAKER RING 20	2
K122	DFHR3D20ZA	SOLENOID LINE HOLD SHEET	1

K123	DFHR3D21YA	LINE HOLD SHEET 1	8
K124	DFHR3D22ZA	LINE HOLD SHEET 2	1
K125	DFHR3D26YA	PAD WP SHEET	1
K126	DFHR3D27ZA	DISK SPRING BACKUP SHEET	1
K127	DFHR3D28ZA	PAD SW SHEET	1
K128	DFHR3D29ZA	BREAK LEBER SHEET	1
K129	DFHR3D30ZA	KBD HOOK WP SHEET	2
K130	DFHR3D33ZA	SIDE WP SHEET2	3
K131	DFHR3D61ZA	AUDIO JK SHEET	1
K132	DFHR3D63ZA	SOLENOID SPACER	1
K133	DFHR3D74ZA	WATER DETECTOR	2
K134	DFHR3D78ZA	DISK COVER SPACER 1	1
K135	DFHR3D79ZA	DISK COVER SPACER 2	1
K136	DFHR3D83ZA	LINE HOLD SHEET 8	1
K137	DFHR3D85ZA	DISK COVER SHEET	1
K138	DFHR3E05ZA	KBD BACKUP SHEET	1
K139	DFHR3E11ZB	DISK SHAFT FIX SHEET	1
K140	DFHR3E38ZA	BOTTOM BATTERY SHEET	1
K141	DFHR3E86ZA	POWER KNOB SHEET	1
K142	DFHR3E87ZA	DVD KNOB SHEE	1
K143	DFHR3F17ZA	WLAN KNOB SHEET	1
K144	DFHR6175ZA	DISK COVER LOCK HOLDER	2
K145	DFHR6188ZA	DISK LOCK BUSH	2
K146	DFHR6236ZA	DISK COVER HOOK	2
K147	DFHR6267ZA	DISK COVER SIDE HOOK	1
K148	DFHR6268ZA	WATER CAP	1
K149	DFKE0815ZA-0	DIMM COVER LIGHT	1
K150	DFKE0841ZA	DISK ANGLE	1
K151	DFKF0268YA-0	BOTTOM CASE	1
K152	DFHG377ZA-0	FOOT RUBBER	2
K153	DFGX0469ZA-0	FOOT CENTER OS	1
K154	DFGX0468ZA-0	FOOT RUBBER SUPPORT	2
K155	DFKM0509XA-0	TOP CASE WAN	1
K156	DFKM0511ZA-0	DISK COVER	1
K157	DFMD1199ZA	DISK COVER LOCK	1
K158	DFMD1201ZA	SOLENOID ANGLE	1
K159	DFMD2174ZA	HDD BACKUP PLATE	1
K160	DFMX0881ZA	INSULATION SHEET	1
K161	DFMX1229ZA	DVD PWB SHEET	1
K162	DFMY0432ZA	DIMM THERMAL SPONGE	1
K163	DFMY3231ZA	DIMM HEAT SHEET	1
K164	DFQT6342ZA	DIMM COVER SHEET T5	1
K165	DFUD0041ZA	LCD LATCH SPRING	1
K166	DFUD0042ZA	DISK COVER LOCK SPRING	1
K167	DFUN0081ZA	DISK COVER ARM SPRING	1
K168	DFUS0313ZA	DISK COVER CLICK WP	1
K169	JDBC0044ZA	BREAK SPRING	1
K170	JDBG0032ZA	BREAK PAD	1
K171	JDKJ0059ZA	BREAK LEVER	1
K172	DFHR6232ZB	MODEM LAN HOLDER	1
K173	DFMX1230ZB	PCMCIA SHEET	1
K174	DFMX1244ZA	LAN ESD SHEET	1
K175	DFMY3225ZA	MEMORY SPREADER	2
K176	DFQT0046ZA	VISTA CAPABLE LABEL	1
K177	 DFGT1209ZA	BOTTOM SHEET	1
N1	DFHE5035ZB	SCREW	2
N2	DRQT2+E8FKL	SCREW	3

N3	DXHM0049ZA	SCREW	2
N4	DXHM0056ZA	SCREW	5
N5	DXHM0057ZA	SCREW	8
N6	DXQT2+D25FNL	SCREW	13
N7	DXQT2+D4FNL	SCREW	3
N8	DXQT2+E10FNL	SCREW	4
N9	DXQT2+E12FNL	SCREW	8
N10	DXQT2+E6FNL	SCREW	11
N11	DXYN26+J6FNM	SCREW	2
N12	XTB26+10GFN	SCREW	2
N13	DXQT2+F2FNL	SCREW	1
N14	XSB2+4FNL	SCREW	1
N15	K1YE50000022	SCREW, IO PIN	2
N16	DXQT2+F3FNL	SCREW	4
N17	DRHM0076ZA	SCREW	4

# Replacement Parts List

Note: Important Safety Notice

Components identified by  mark have special characteristics important for safety.  
When replacing any of these components use only manufacturer's specified parts.

## CF-Y5LWVYZBM (2006/11/16)

REF. NO and AREA	PART NO.	DESCRIPTION	Q'TY
<b>MAIN PCB</b>			
C 1, 212, 708, 711	EEFSX0D331ER	CAPACITOR, 2V, 330µF	4
C 2, 3, 4, 6, 7, 8, 11, 12, 13, 15, 16, 17, 19, 20, 21, 23, 24, 25, 26, 29, 30, 31, 32, 33, 34, 35, 36, 37, 38, 39, 40, 41	F1J0J1060004	CAPACITOR, 6.3V, 10µF	36
C 5, 60, 61, 69, 89, 181,	EEFCX0D221R	CAPACITOR, 2V, 220µF	7
C 9, 10, 14, 18, 22, 27, 50, 51, 52, 57, 64, 65, 66, 68, 71, 85, 90, 92, 95, 96, 99, 100, 101, 102, 105, 106, 107, 108, 111, 112, 114, 115, 118, 119, 127, 128, 134, 135, 136, 137, 142, 143, 144, 145, 146, 147, 148, 168, 169, 170, 171, 175, 177, 178, 180, 182, 183, 187, 188, 189, 190, 191, 192, 193, 194, 195, 196, 197, 198, 199, 200, 201, 202, 203, 204, 205, 207, 208, 210, 217, 219, 221, 222, 228, 233, 234, 236, 239, 241, 243, 245, 247, 249, 252, 255, 257, 262, 275, 283, 289, 290, 291, 292, 293, 294, 295, 296, 298, 305, 310, 311, 313, 314, 315, 316, 317, 318, 319, 321, 323, 326, 328, 332, 347, 358, 364, 375, 377, 378, 379, 383, 384, 386, 392, 393, 394, 402, 406, 413, 430, 431, 434, 435, 436, 437, 438, 442, 444, 445	F1G1C104A042	CAPACITOR, 16V, 0.1µF	156
C 46, 151, 152, 153, 154, 174, 179, 218, 230, 231, 238, 240, 260, 272, 277, 308, 312, 340, 401, 602, 605, 692, 731	F1G1E103A062	CAPACITOR, 25V, 0.01µF	23
C 48, 58, 59, 62, 63, 70, 72, 74, 87, 93, 167, 176, 206, 254, 297, 303, 304, 325, 339, 368, 395, 441, 446, 447, 668, 695	F1J0J106A016	CAPACITOR, 6.3V, 10µF	26
C 49, 251	F1G1H222A496	CAPACITOR, 50V, 2200pF	2
C 53, 54, 165, 166, 337, 342, 343, 344, 345, 729, 730	F1G1A104A014	CAPACITOR, 10V, 0.1µF	11
C 55, 56, 67, 78, 79, 94, 97, 98, 103, 104, 109, 110, 113, 116, 117, 138, 139, 140, 141, 172, 173, 184, 186, 214, 216, 237, 301, 322, 338, 346, 351, 390, 399, 606, 694, 702	F1H1A1050015	CAPACITOR, 10V, 1µF	36
C 73, 76, 88, 91	F1G1A474A018	CAPACITOR, 10V, 0.47µF	4

C 77, 80, 149, 150, 330, 341, 348, 370, 372, 373, 374, 409, 421	F1J0J4750019	CAPACITOR, 6.3V, 4.7µF	13
C 81, 82, 83, 84, 86, 129, 155, 156, 157, 158, 391, 414	F1H0J1050022	CAPACITOR, 6.3V, 1µF	12
C 120, 121	F1G1H3R3A543	CAPACITOR, 50V, 3.3pF	2
C 159, 160, 620, 623, 628, 667, 683, 686	F1G1H220A542	CAPACITOR, 50V, 22pF	8
C 213, 215	F1G1H4R0A543	CAPACITOR, 50V, 4pF	2
C 223, 224, 226, 227, 281, 282, 284, 285, 286, 287, 288	F1G1H330A542	CAPACITOR, 50V, 33pF	11
C 225, 229, 256, 360, 361, 387, 388, 389, 403, 405, 407, 408, 422, 423, 424, 425, 426, 427, 428, 429, 443, 619, 622, 626, 644, 647, 663, 665, 670, 682, 689, 714, 716	F1G1H102A496	CAPACITOR, 50V, 1000pF	33
C 235, 624, 649, 687, 718, 726	F1J0J475A009	CAPACITOR, 6.3V, 4.7µF	6
C 242, 248	F1G1H8R0A544	CAPACITOR, 50V, 8pF	2
C 279, 398, 614, 629, 705, 706, 707, 722, 723, 732, 733, 734	F1K1E106A078	CAPACITOR, 25V, 10µF	12
C 280, 306, 307, 362, 363, 385, 615, 664, 691	F1G1H1010005	CAPACITOR, 50V, 100pF	9
C 320, 324	F1G1H5R0A543	CAPACITOR, 50V, 5pF	2
C 329	F1L3D1020006	CAPACITOR, 1KV, 1000pF	1
C 333, 334, 335, 336, 349, 353, 366	F1G0J224A001	CAPACITOR, 6.3V, 0.22µF	7
C 354, 356	F1L0J107A016	CAPACITOR, 6.3V, 100µF	2
C 367, 439	F1G1H471A496	CAPACITOR, 50V, 470pF	2
C 400	F1G1A683A014	CAPACITOR, 10V, 0.068µF	1
C 411, 412, 642	F1G1H470A542	CAPACITOR, 50V, 47pF	3
C 415	F1L1H220A066	CAPACITOR, 50V, 22pF	1
C 601	F1H1H104A731	CAPACITOR, 50V, 0.1µF	1
C 603, 651, 652, 653, 658, 673, 677, 693	F1L1E106A021	CAPACITOR, 25V, 10µF	8
C 607	F1J1E105A009	CAPACITOR, 25V, 1µF	1
C 608	F1J1E104A081	CAPACITOR, 25V, 0.1µF	1
C 611, 612	EEFCX0J101R	CAPACITOR, 6.3V, 100µF	2
C 616, 618, 625, 659, 662, 669, 678, 681, 688, 697, 699, 700, 703, 704, 719	F1H1H104A748	CAPACITOR, 50V, 0.1µF	15
C 617, 627	F1H1H103A748	CAPACITOR, 50V, 0.01µF	2
C 621, 648, 661, 666, 672, 679, 684, 685, 725	F1G1H221A495	CAPACITOR, 50V, 220pF	9
C 630, 675	EEFCX0G151R	CAPACITOR, 2V, 150µF	2
C 631, 636, 637, 638, 640, 724	F1G1C473A004	CAPACITOR, 16V, 0.047µF	6
C 643	F1G1H151A495	CAPACITOR, 50V, 150pF	1
C 645	F1H1H1830001	CAPACITOR, 50V, 0.018µF	1
C 646	F1G1H561A496	CAPACITOR, 50V, 560pF	1
C 650	F1J1H224A533	CAPACITOR, 50V, 0.22µF	1
C 657, 676, 696	EEFCD0D101ER	CAPACITOR, 2V, 100µF	3
C 660, 690	F1H1H472A748	CAPACITOR, 50V, 4700pF	2
C 671, 680	F1H1H182A748	CAPACITOR, 50V, 1800pF	2
C 698	EEFCD0D151ER	CAPACITOR, 2V, 150µF	1
C 701	F1G1H152A496	CAPACITOR, 50V, 1500pF	1
C 715	F1G1H331A496	CAPACITOR, 50V, 330pF	1
C 720	F1H1H222A748	CAPACITOR, 50V, 2200pF	1
CF 1	D4CC1103A038	THERMISTOR	1
CN 2	K1MMH2B00003	CONNECTOR	1
CN 3, 26, 27	K1KA02BA0014	CONNECTOR	3



CN 4		K1MN50BA0153	CONNECTOR	1
CN 6		K1MN24BA0070	CONNECTOR	1
CN 7		K1FY150BA007	CONNECTOR	1
CN 8		K1MN60B00008	CONNECTOR	1
CN 9		K1KA05BA0181	CONNECTOR	1
CN 10		K1KY30BA0062	CONNECTOR	1
CN 11		K1FB315BA003	CONNECTOR	1
CN 12		K1NA09E00076	CONNECTOR	1
CN 13		K1NA68E00096	CONNECTOR	1
CN 14		K1KA08BA0181	CONNECTOR	1
CN 15		K1KA04BA0014	CONNECTOR	1
CN 17		K1KY12A00004	CONNECTOR	1
CN 18		K1MY52BA0190	CONNECTOR	1
CN 20		K1MN12BA0070	CONNECTOR	1
CN 21		K1MY10BA0105	CONNECTOR	1
CN 23		K1KA12BA0181	CONNECTOR	1
CN 24		K1MY16BA0097	CONNECTOR	1
CN 25		K1MY10BA0102	CONNECTOR	1
CN 600		K1KA10B00233	CONNECTOR	1
CN 601		K1KA02B00292	CONNECTOR	1
D 1, 2, 3, 10		MA2J72900L	DIODE	4
D 4		MA3J741E0L	DIODE	1
D 5, 6		B0KB00000044	DIODE	2
D 7, 8, 9, 601, 602, 604		B0ADDH000004	DIODE	6
D 11, 600, 603		B0JCPD000023	DIODE	3
D 12, 619, 621		MA2S111-TX	DIODE	3
D 13,		B3ABB0000196	DIODE	1
D 14		B3AKB0000008	DIODE	1
D 15, 20		B3ACB0000020	DIODE	2
D 16, 17, 18, 19		B3ABB0000164	DIODE	4
D 605		MAZ81200ML	DIODE	1
D 606		MAZ81800ML	DIODE	1
D 607, 622		MA3S132E0L	DIODE	2
D 608		B0JCQD000001	DIODE	1
D 609, 611, 624, 626, 627, 629, 630, 633		B0JCMD000010	DIODE	8
D 610, 625, 628		B0JDAE000004	DIODE	3
D 612, 613, 614, 615, 617, 618		MAZ80510ML	DIODE	6
D 616		MAZ80620ML	DIODE	1
D 620		B2ABAM000002	DIODE	1
D 623, 632, 640		DEDRB081L20	DIODE	3
D 634		MAZ80750ML	ZENER DIODE	1
F 1, 2		K5H2021A0003	FUSE, 2A	2
F 4		K5H402Z00003	FUSE, 4A, 32V	1
F 6		K5H202Z00005	FUSE, 2A, 32V	1
F 600		K5H802300002	FUSE, 8A	1
IC 1		C2GBC0000304	CPU	1
IC 2		C1CB00002432	IC, CHIP SET	1
IC 3		C1DB00001541	IC, CHIPSET	1
IC 4		C0DBZY00017	IC	1
IC 5, 6, 7, 8, 9, 10, 11, 12		C3ABSG000030	IC, SDRAM	8
IC 13		C0JBZZ000388	IC, CLOCK GENERATOR	1
IC 15		C0CBCAC00183	IC, REGULATOR	1
IC 16		C0CBCBG00008	IC, REGULATOR	1
IC 17		C1DB00001182	IC, LAN CONTROLLER	1
IC 18		C3EBCG000100	IC, EEPROM	1
IC 19		C0CBCBC00137	IC, REGULATOR	1
IC 20		C1CB00002540	IC, TEMPERATURE SENSOR IC	1
IC 21, 22, 69		C0DBZY00026	IC, USB POWER SW	3
IC 23		C3EBEC000061	IC, EEPROM	1

IC 24		C1DB00001373	IC, USB-ATA CHIP	1
IC 25, 64, 68		C0JBAZ002422	IC, FET SWITCH	3
IC 26, 37, 38		C0EBE0000460	IC	3
IC 27, 29		C0JBAR000515	IC, Q-SWITCH	2
IC 28		C0DBZY00016	IC	1
IC 30		C1CB00002449	IC, AUDIO CODEC	1
IC 31		C0CBCBC00181	IC	1
IC 32		C1AB00002507	IC, AUDIO POWER AMPLIFIER	1
IC 33		C1CB00002268	IC, SECURITY CHIP	1
IC 34		C3FBLY000024	IC, SPI FLASH MEMORY	1
IC 36		C2CBJA000003	IC, MICON	1
IC 42		C0JBAB000832	IC, LOGIC	1
IC 43, 44, 54, 55, 61, 614		C0JBAA000362	IC, LOGIC	6
IC 45, 51		C0JBAE000321	IC, LOGIC	2
IC 46, 47, 48, 49,		C0JBAA000345	IC, LOGIC	4
IC 50		C1CB00002295	IC	1
IC 52, 603, 604		C0JBAB000621	IC, LOGIC	3
IC 53, 601		C0ABBA000093	IC, OP AMP	2
IC 58		C0DBZY00019	IC, POWER MANAGEMENT SWITCH	1
IC 63		C0JBAB000686	LOGIC IC	1
IC 600, 602, 609		C0DBALH00003	IC	3
IC 605		C0DBAYY00155	IC, DC/DC	1
IC 606		C0DBEFH00002	IC, REGULATOR	1
IC 607		C0DBDJH00009	IC, LINER	1
IC 608		C0ABZA000047	IC, AMP	1
IC 610		C0EBE0000333	IC	1
IC 615		C0DBAZZ00098	IC	1
IC 617		C0EBE0000591	IC, RESET	1
KJ 1, 2		K2HC1YYB0027	JACK	2
L 1, 3		G1C1R0MA0076	INDUCTOR	2
L 2		G1C91NM00001	INDUCTOR	1
L 4		J0JJC0000021	INDUCTOR	1
L 5, 7, 11, 15, 26		J0JHC0000074	INDUCTOR	5
L 9, 10, 13, 14, 27, 28, 29, 30, 31, 32, 33		J0JCC0000186	INDUCTOR	11
L 17, 18, 19		J0JBC0000072	INDUCTOR, FILTER	3
L 20		G1C1R0Z00002	INDUCTOR	1
L 21, 22, 23, 24		J0ZZB0000080	INDUCTOR, COMMON MODE FILTER	4
L 25		DDB5Z024E-L	INDUCTOR	1
L 34, 35, 36, 37		DDB5Z024C-L	INDUCTOR, FERRITE PARTS	4
L 38, 39, 40, 41, 42, 43		DDB5Z021C-Y	INDUCTOR	6
L 44		J0MAB0000116	INDUCTOR	1
L 600		J0JKC0000007	INDUCTOR	1
L 601, 606, 607		G1C4R7MA0022	INDUCTOR	3
L 602		G1C100MA0022	INDUCTOR	1
L 603		G1CR56ZA0140	COIL	1
L 604		G1C2R8MA0022	INDUCTOR	1
L 605		G1C220MA0077	INDUCTOR	1
L 608		G1A160H00001	INDUCTOR	1
L 609		G1C4R7MA0273	COIL	1
PA 1, 2, 3		D4FB1R100009	SWITCH	3
Q 1, 24		B1GDCFNN0031	TRANSISTOR	2
Q 2, 3, 4, 25, 34, 604, 606, 619, 645, 646, 651, 652, 653, 657, 658.		B1GBCFJN0037	TRANSISTOR	15
Q 5, 622, 627		B1CHRC000009	FET	3
Q 6, 7, 27, 654, 662		B1CFGD000023	TRANSISTOR	5
Q 10, 36, 38, 616, 621, 628, 631, 632, 634, 635,		XP0421300L	TRANSISTOR	11
Q 11, 30, 626, 630, 633		B1DHDC000028	TRANSISTOR	5
Q 19		B1GDCFJJ0050	TRANSISTOR	1
Q 20, 21		XP0411300L	TRANSISTOR	2

Q 26		B1GFCFEN0003	TRANSISTOR	1
Q 28, 35, 37		B1MBDCA00004	TRANSISTOR	3
Q 29, 39, 601, 603, 605, 611, 624		B1GBCFNN0042	TRANSISTOR	7
Q 40		B1GBCFNL0017	TRANSISTOR	1
Q 600		XP0421400L	TRANSISTOR	1
Q 602		B1CFMC000008	TRANSISTOR	1
Q 607, 608, 609, 610		B1CHRD000001	TRANSISTOR	4
Q 612, 613		B1CFRD000014	FET	2
Q 614, 643, 647, 659		B1CFGD000003	TRANSISTOR	4
Q 615, 644		B1MBEDA00017	TRANSISTOR	2
Q 637, 639, 641, 642, 650, 656, 660		B1DBGD000006	TRANSISTOR	7
Q 638, 640		B1DFGD000032	TRANSISTOR	2
Q 648		B1MBEDA00018	TRANSISTOR	1
Q 649		B1CFRD000013	FET	1
Q 655		B1DHFD000015	TRANSISTOR	1
Q 661, 665		B1DHFD000017	TRANSISTOR	2
R 1, 57, 58, 62, 190, 218, 235, 272, 273, 275, 392, 393, 478, 479, 480, 492, 656		ERJ2GEJ102X	RESISTOR, 1/16W, 1K $\Omega$	17
R 2, 5, 6, 9		ERJ2GEJ510X	RESISTOR, 1/16W, 51 $\Omega$	4
R 13, 14, 65, 203, 237, 332, 350, 362, 413, 464, 465, 466, 467, 473, 474, 502, 504, 508, 608, 609, 667, 668, 673, 676, 677, 678, 679, 697, 811		ERJ2GEJ101X	RESISTOR, 1/16W, 100 $\Omega$	29
R 15, 695, 696		ERJ2RKF1001X	RESISTOR, 1/16W, 1K $\Omega$	3
R 16		ERJ2RKF2001X	RESISTOR, 1/16W, 2K $\Omega$	1
R 18		ERJ2RKF51R0X	RESISTOR, 1/16W, 51 $\Omega$	1
R 19, 21		ERJ2RKF27R4X	RESISTOR, 1/16W, 27.4 $\Omega$	2
R 20, 22, 32, 33		ERJ2RKF54R9X	RESISTOR, 1/16W, 54.9 $\Omega$	4
R 24		ERJ2GEJ680X	RESISTOR, 1/16W, 68 $\Omega$	1
R 25, 27, 28		ERJ2GEJ560X	RESISTOR, 1/16W, 56 $\Omega$	3
R 26		ERJ3GEYJ201V	RESISTOR, 1/16W, 200 $\Omega$	1
R 30, 34, 35, 86, 228		ERJ2RKF24R9X	RESISTOR, 1/16W, 24.9 $\Omega$	5
R 31, 354, 610, 614, 616, 747		ERJ2GEJ562X	RESISTOR, 1/16W, 5.6K $\Omega$	6
R 37, 39		ERJ2RKF2210X	RESISTOR, 1/16W, 221 $\Omega$	2
R 38, 40, 42		ERJ2RKF1000X	RESISTOR, 1/16W, 100 $\Omega$	3
R 41		ERJ2RKF2000X	RESISTOR, 1/16W, 200 $\Omega$	1
R 63		ERJ2RKF1002X	RESISTOR, 1/16W, 10K $\Omega$	1
R 66, 319, 320, 325, 326, 394, 395		ERJ2GEJ222X	RESISTOR, 1/16W, 2.2K $\Omega$	7
R 74, 75		ERJ2RKF80R6X	RESISTOR, 1/16W, 80.6 $\Omega$	2
R 78, 170, 196, 197, 220, 268		D1H81034A024	RESISTOR ARRAY	6
R 79, 80		ERJ2GEJ390X	RESISTOR, 1/16W, 39 $\Omega$	2
R 81, 285		ERJ2RKF1501X	RESISTOR, 1/16W, 1.5K $\Omega$	2
R 82		ERJ2RKF2550X	RESISTOR, 1/16W, 255 $\Omega$	1
R 83, 84, 85, 327, 328, 329, 488, 489, 490		ERJ2RKF1500X	RESISTOR, 1/16W, 150 $\Omega$	9
R 91		ERJ3GEYJ220V	RESISTOR, 1/16W, 22 $\Omega$	1

R 93, 176, 177, 234, 243, 263, 264, 277, 282, 283, 284, 289, 290, 291, 298, 300, 303, 315, 335, 336, 338, 348, 349, 358, 372, 374, 388, 391, 396, 399, 402, 415, 421, 422, 426, 428, 437, 444, 447, 448, 452, 453, 471, 472, 483, 484, 619, 639, 644, 688, 704, 708, 712, 713, 728, 732, 734, 742, 800		ERJ2GEJ103X	RESISTOR, 1/16W, 10KΩ	59
R 95, 96, 97, 98		ERJ2GEJ201X	RESISTOR, 1/16W, 200Ω	4
R 99, 100, 101, 102, 127, 128, 129, 130		D1HG1008A001	RESISTOR ARRAY	8
R 103, 104, 105, 106, 107, 108, 109, 110, 111, 112, 113, 114, 115, 116, 117, 118, 119, 120, 121, 122, 123, 124, 125, 126, 341, 636, 637, 649, 650, 705, 706, 716, 717, 725, 726, 737, 738		ERJ2GEJ100X	RESISTOR, 1/16W, 10Ω	37
R 131, 132, 133, 134, 135, 136, 137, 138, 139, 140, 141, 142, 143, 144, 145, 146, 147, 148, 149, 150, 151, 152, 153, 154, 155, 156, 172, 189, 192, 194, 224, 226, 233, 238, 239, 240, 247, 252, 257, 299, 317, 333, 346, 385, 407, 430, 435, 439, 440, 449, 450, 458, 481, 485, 487, 491, 501, 511, 512, 600, 692, 703, 719, 760, 761, 763, 768, 773, 774, 785, 787		ERJ2GE0R00X	RESISTOR, 1/16W, 0Ω	71
R 157, 158, 159, 160, 161, 162, 163		D1HA56080001	RESISTOR ARRAY	7
R 165, 171, 215, 248, 249, 250, 308, 309, 310, 311, 331, 334, 337, 342, 343, 352, 383, 454, 459, 460, 461, 475, 476, 503, 506, 611, 621, 623, 624, 625, 662, 664, 666, 672, 781, 782, 797		ERJ2GEJ104X	RESISTOR, 1/16W, 100KΩ	37
R 166, 167, 168, 169, 245, 699, 762, 769		ERJ3GEYJ1R0V	RESISTOR, 1/16W, 1Ω	8
R 174		D1H81004A024	RESISTOR ARRAY	1
R 179, 180, 181, 182, 183, 184, 185, 186, 191, 217, 271, 278, 279, 368, 404, 424, 493, 494, 496, 497, 498, 499		ERJ2GEJ330X	RESISTOR, 1/16W, 33Ω	22
R 216		D1H84724A024	RESISTOR ARRAY	1
R 219, 265, 266, 267, 455, 456, 457, 486		DEARA8AJ103M	RESISTOR ARRAY	8
R 221, 222, 295, 443, 463, 469		ERJ2GEJ470X	RESISTOR, 1/16W, 47Ω	6
R 229		ERJ2RKF22R6X	RESISTOR, 1/16W, 22.6Ω	1
R 242, 254, 270, 292, 347, 370, 371, 378, 400, 505, 515, 517, 620, 634, 684, 780		ERJ2GEJ473X	RESISTOR, 1/16W, 47KΩ	16
R 246		ERJ3GEYJ121V	RESISTOR, 1/16W, 120Ω	1
R 255, 280, 355, 653		ERJ2GEJ334X	RESISTOR, 1/16W, 330KΩ	4
R 258		ERJ2GEJ203X	RESISTOR, 1/16W, 20KΩ	1
R 259		ERJ2GEJ106X	RESISTOR, 1/16W, 10MΩ	1

R 260, 361, 397, 398, 622, 661, 669	ERJ2GEJ105X	RESISTOR, 1/16W, 1MΩ	7
R 261	ERJ2RKF3922X	RESISTOR, 1/16W, 39.2KΩ	1
R 262	ERJ2RKF2002X	RESISTOR, 1/16W, 20KΩ	1
R 274, 302, 754	ERJ2GEJ472X	RESISTOR, 1/16W, 4.7KΩ	3
R 286, 287	ERJ2RKF39R0X	RESISTOR, 1/16W, 39Ω	2
R 288	ERJ2RKF2431X	RESISTOR, 1/16W, 2.43KΩ	1
R 294, 296, 767, 775, 776	ERJ3GEY0R00V	RESISTOR, 1/16W, 0Ω	5
R 314, 316, 330, 380	ERJ6GEY0R00V	RESISTOR, 1/10W, 0Ω	4
R 339, 495	J0JCC0000396	RESISTOR, 1/16W, 120Ω	2
R 353	ERJ2RHD562X	RESISTOR, 1/16W, 5.6KΩ	1
R 356, 357, 359, 360	ERJ2RKF49R9X	RESISTOR, 1/16W, 49.9Ω	4
R 367	EXBV8V750JV	RESISTOR ARRAY	1
R 369, 759	ERJ2RKF5101X	RESISTOR, 1/16W, 5.1KΩ	2
R 376, 377	ERJ3GEYJ330V	RESISTOR, 1/16W, 33Ω	2
R 384	D1H84734A024	RESISTOR ARRAY	1
R 386	ERJ2GEJ1R0X	RESISTOR, 1/16W, 1Ω	1
R 387, 390, 680	ERJ2GEJ223X	RESISTOR, 1/16W, 22KΩ	3
R 401, 470, 757	ERJ2GEJ471X	RESISTOR, 1/16W, 470Ω	3
R 446	ERJ2RKF3901X	RESISTOR, 1/16W, 3.9KΩ	1
R 451, 603, 607	ERJ2RHD103X	RESISTOR, 1/16W, 10KΩ	3
R 462	ERJ6GEYJ221V	RESISTOR, 1/10W, 220Ω	1
R 468	ERJ2GEJ391X	RESISTOR, 1/16W, 390Ω	1
R 507	ERJ2GEJ273X	RESISTOR, 1/16W, 27KΩ	1
R 513	ERJ2GEJ181X	RESISTOR, 1/16W, 180Ω	1
R 601	ERJ3GEYJ562V	RESISTOR, 1/16W, 5.6KΩ	1
R 602	D1ZZ00000046	RESISTOR, 1W, 5mΩ	1
R 604	D1BDR4700001	RESISTOR, 1/8W, 0.47Ω	1
R 605, 613	ERJ2RKD244X	RESISTOR, 1/16W, 240KΩ	2
R 606, 612	ERJ2RKD364X	RESISTOR, 1/16W, 360KΩ	2
R 615, 617	ERJ1TYJ331U	RESISTOR, 1W, 330Ω	2
R 618	ERJ3GEYJ3R3V	RESISTOR, 1/16W, 3.3Ω	1
R 626, 627	D1BDR1000002	RESISTOR, 1/8W, 0.1Ω	2
R 628, 755, 756	D1BDR0680001	RESISTOR, 1/8W, 0.068Ω	3
R 629, 701, 702, 724, 741, 742, 777	D1BDR0220001	RESISTOR, 1/8W, 0.022Ω	7
R 630, 631	D1BDR018A099	RESISTOR, 1/3W, 0.018Ω	2
R 632	ERJ2RKF1102X	RESISTOR, 1/16W, 11KΩ	1
R 633	ERJ2RKF1302X	RESISTOR, 1/16W, 13KΩ	1
R 635, 654, 718, 720, 739, 745, 772, 778	ERJ2GEJ474X	RESISTOR, 1/16W, 470KΩ	8
R 638, 707, 727	ERJ2GEJ153X	RESISTOR, 1/16W, 15KΩ	3
R 640, 709, 729	ERJ3GEYJ100V	RESISTOR, 1/16W, 10Ω	3
R 641, 648	ERA3YEB622V	RESISTOR, 1/16W, 6.2KΩ	2
R 642, 751	ERA3YKB104V	RESISTOR, 1/16W, 100KΩ	2
R 643, 731	ERA3YEB203V	RESISTOR, 1/16W, 20KΩ	2
R 645	ERJ2GEJ333X	RESISTOR, 1/16W, 33KΩ	1
R 646	ERA3YEB333V	RESISTOR, 1/16W, 33KΩ	1
R 647, 753	ERA3YEB123V	RESISTOR, 1/16W, 12KΩ	2
R 651, 652, 723	D1BDR0330001	RESISTOR, 1/8W, 0.033Ω	3
R 663	ERJ2GEJ684X	RESISTOR, 1/16W, 680KΩ	1
R 665	ERJ2GEJ225X	RESISTOR, 1/16W, 2.2MΩ	1
R 681, 814	ERJ6GEYJ122V	RESISTOR, 1/10W, 1.2KΩ	2
R 682, 683	ERJ6GEYJ222V	RESISTOR, 1/10W, 2.2KΩ	2
R 687	ERJ2RKF5103X	RESISTOR, 1/16W, 510KΩ	1
R 689	ERJ2RKF1003X	RESISTOR, 1/16W, 100KΩ	1
R 690	ERJ2RKF1800X	RESISTOR, 1/16W, 180Ω	1
R 693	ERJ2RHD222X	RESISTOR, 1/16W, 2.2KΩ	1
R 694, 710	ERJ2RKF4701X	RESISTOR, 1/16W, 4.7KΩ	2
R 700	D1ZZ000000093	RESISTOR, 1W, 1mΩ	1
R 711, 735	ERJ2RKF1502X	RESISTOR, 1/16W, 15KΩ	2
R 714	ERJ2RKF5102X	RESISTOR, 1/16W, 51KΩ	1

R 715		ERJ2RKF2402X	RESISTOR, 1/16W, 24KΩ	1
R 721, 779, 824		D1BDR0470002	RESISTOR, 1/8W, 0.047Ω	3
R 730		ERA3YEB621V	RESISTOR, 1/16W, 620Ω	1
R 732		ERA3YEB243V	RESISTOR, 1/16W, 24KΩ	1
R 736		ERJ2RHD123X	RESISTOR, 1/16W, 12KΩ	1
R 740		ERJ2GEJ221X	RESISTOR, 1/16W, 220Ω	1
R 744		ERJ2RKD114X	RESISTOR, 1/16W, 110KΩ	1
R 746		ERJ2RHD3652X	RESISTOR, 1/16W, 36.5KΩ	1
R 748		ERJ2GEJ154X	RESISTOR, 1/16W, 150KΩ	1
R 749, 750		ERJ2RHD302X	RESISTOR, 1/16W, 3KΩ	2
R 752		ERA3YEB153V	RESISTOR, 1/16W, 15KΩ	1
R 758		ERJ2RKF4702X	RESISTOR, 1/16W, 47KΩ	1
R 766,		ERJ3GEYJ101V	RESISTOR, 1/16W, 100Ω	1
R 771		ERJ2RKF6801X	RESISTOR, 1/16W, 6.80KΩ	1
R 783		ERJ2RKD1403X	RESISTOR, 1/16W, 140KΩ	1
R 784		ERJ2RHD2002X	RESISTOR, 1/16W, 20KΩ	1
R 790, 791		ERA3YKB154V	RESISTOR, 1/16W, 150KΩ	2
SW 1		K0D112B00071	SW	1
SW 2		ESD165225	SLIDE SWITCH	1
SW 3, 4		EVQPLDA15	SWITCH	2
SW 5		K0ZZ00000617	SW	1
T 1		G5BYC0000015	TRANCE	1
X 1		H0J143500058	OSCILLATOR, 14.318MHz	1
X 2		H0J327200115	OSCILLATOR, 32.768KHz	1
X 3		H0J300500018	CRYSTAL OSCILLATOR	1
X 4		H0J250500067	OSCILLATOR, 25MHz	1
X 5		H2D800400015	OSCILLATOR, 8MHz	1
ZA 1, 2		DRHM0113ZA	SCREW	2
ZA 3, 4		K1YGZZ000060	SPACER	2
<b>SUB PCB</b>				
C 903		F1G1C104A042	CAPACITOR, 16V, 0.1μF	1
CN 900		K1MN20BA0070	CONNECTOR	1
D 901		B3ABB0000196	DIODE	1
IC 901		C0JBAA000345	IC, LOGIC	1
Q 901		B1GBCFJN0037	TRANSISTOR	1
R 903		ERJ3GEYJ101V	RESISTOR, 1/16W, 100Ω	1
SW 900, 901		K0L1BA000115	SW	2
SW 902		K0D113B00081	SW	1
<b>BLUETOOTH PCB</b>				
C 1201, 1202		EEFUD0J151ER	CAPACITOR, 6.3V, 150μF	2
C 1203, 1206, 1213		F1G1C104A042	CAPACITOR, 16V, 0.1μF	3
C 1204, 1210		F1G1E103A062	CAPACITOR, 25V, 0.01μF	2
C 1205		F1J0J106A016	CAPACITOR, 6.3V, 10μF	1
C 1207, 1209		F1G1H102A496	CAPACITOR, 50V, 1000pF	2
C 1212		F1G1H6R0A544	CAPACITOR, 50V, 6pF	1
C 1214		ECJ0EC1H0R5C	CAPACITOR, 50V, 0.5pF	1
CN 1201		K1MN24BA0070	CONNECTOR	1
CN 1202, 1203		K1FY104BA024	CONNECTOR, USB	2
D 1201, 1202		B0KB00000044	DIODE	2
IC 1201		C0JBAZ002422	IC, FET SWITCH	1
IC 1202		N5HZZ0000040	BLUETOOTH MODULE	1
IC 1203		C0EBE0000460	IC	1
KJ 1201		K1QZA1AE0001	CONNECTOR	1
L 1201, 1202		J0MAB0000116	INDUCTOR	2
L 1203, 1204, 1205, 1206		J0JHC0000074	INDUCTOR	4
L 1207		J0JJC0000015	INDUCTOR	1
L 1209		J0MAB0000200	INDUCTOR	1
L 1210		G1C10NJA0024	INDUCTOR	1
Q 1201		B1GBCFNN0042	TRANSISTOR	1
Q 1202		B1DHDC000028	TRANSISTOR	1
R 1201, 1202		ERJ2GEJ104X	RESISTOR, 1/16W, 100KΩ	2

R 1203	ERJ2GE0R00X	RESISTOR, 1/16W, 0Ω	1
--------	-------------	---------------------	---